







REVISIONS

P	LTR	DESCRIPTION	DATE	DWN	APVD
	V4	REVISED PER ECN-22-156403	03JUN2022	RK	CSD

300 VOLT MAX		
AMP WIRE RANGE	 Listed FILE E13288	 LR7189 Certified
22-16 AWG SOLID OR STRANDED	22-16 AWG SOLID OR STRANDED	22-16 AWG SOLID OR STRANDED

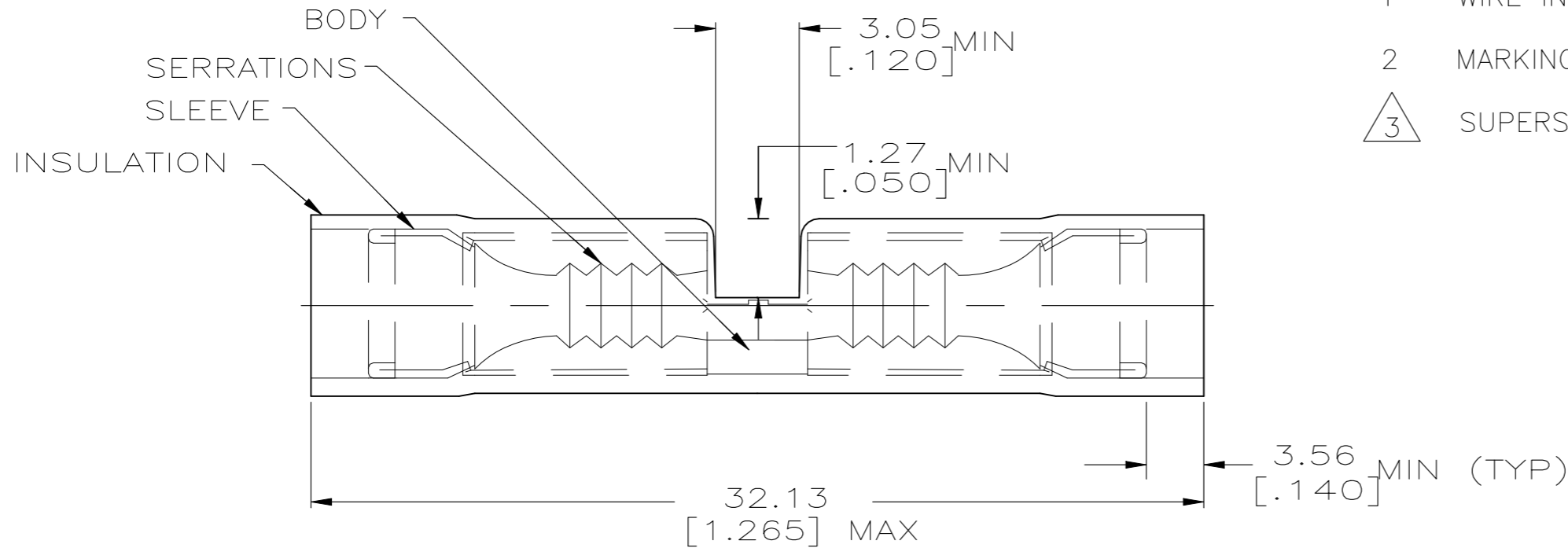
600 VOLT MAX		
AMP WIRE RANGE	 Listed FILE E13288	 LR7189 Certified
22-16 AWG STRANDED	22-16 AWG STRANDED	22-16 AWG STRANDED



- 1 WIRE INSULATION DIA 2.03[.080] TO 3.18[.125]
- 2 MARKING 22-18 FOR MILITARY COMMERCIAL RANGE 22-16
-  SUPERSEDED BY 8-320559-2

-	4000	LOOSE PIECE, CTN	8-320559-6
-	100	LOOSE PIECE, BOX SPL	8-320559-5
-	5	LOOSE PIECE, BLS	8-320559-4 
-	50	LOOSE PIECE, BOX	8-320559-2
-	2500	ON TAPE	2-320559-4
M7928/5-3 CLASS 1		50	LOOSE PIECE
MILITARY PART NUMBER & CLASS PER MIL-T-7928		QTY	PACKAGE TYPE
			PART NO.

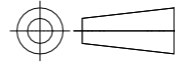
AMP INCORPORATED CUSTOMER SERVICE SYSTEMS		MAX RECOMMENDED OPERATING TEMPERATURE: 105°C [221°F]	THIS DRAWING IS A CONTROLLED DOCUMENT.		DWN S.S. GOULDEN 9-28-93	 TE Connectivity					
FOR ADDITIONAL PRODUCT INFORMATION OR COPIES OF DRAWINGS AND TECHNICAL DOCUMENTS	PRODUCT INFORMATION CENTER 1-800-522-6752	VOLTAGE RATING: 600V MAX (1000V MAX FIXTURE OR SIGN)	DIMENSIONS: mm [INCHES]	TOLERANCES UNLESS OTHERWISE SPECIFIED:	CHK R. HERSEY 9-28-93					NAME SPLICE, BUTT, PIDG WIRE SIZE: 22-16	
FOR APPLICATION TOOLING INFORMATION	TOOLING ASSISTANCE CENTER 1-800-722-1111	CIRCULAR MIL AREA: 0.26-1.65mm² [509-3260]		0 PLC ± - 1 PLC ± - 2 PLC ± 0.20[.008] 3 PLC ± - 4 PLC ± - ANGLES ± -	APVD M ELLIS 9-28-93	PRODUCT SPEC	SIZE	CAGE CODE	DRAWING NO		
FOR ORDER ENTRY	1-800-526-5142	THIS DRAWING IS A CONTROLLED DOCUMENT FOR AMP INCORPORATED. IT IS SUBJECT TO CHANGE AND THE CONTROLLING ENGINEERING ORGANIZATION SHOULD BE CONTACTED FOR THE LATEST REVISION.	MATERIAL COPPER PER ASTM B-152	FINISH TIN PL PER ASTM B545	WEIGHT -	APPLICATION SPEC	A3	00779	C-320559	-	
CUSTOMER DRAWING						SCALE	4:1	SHEET	1 OF 1	REV	V4