

PART NUMBER	REVISION	DESCRIPTION	FEED TYPE
2150383-1	E	FINE CRIMP HEIGHT ADJUST	MECHANICAL
2150383-2	E	FINE CRIMP HEIGHT ADJUST	PNEUMATIC
7-2150383-1	E	MECHANICAL AND CRIMP TOOLING KIT	MECHANICAL
7-2150383-2	E	PNEUMATIC AND CRIMP TOOLING KIT	PNEUMATIC
7-2150383-7	A	CRIMP TOOLING KIT	-

ATLANTIC VERSION TERMINATOR INTERFACE ADAPTER



APPLICATOR DATA		
CRIMP	SIZE	TYPE
WIRE	.055 [1.40 mm]	F
INSUL	.140 [3.56 mm]	F
APPL INSTRUCTIONS 408-35043		

TERMINAL DATA: TE TERMINAL TE CRIMP SPECIFICATION			
TERMINAL NAME: RECEPTACLE, FASTON, .187 SERIES			
WIRE STRIP LENGTH		INSULATION DIAMETER RANGE	
.153-.168 IN [3.87-4.25 mm]		∅.060-.110 IN [1.52-2.79 mm]	
TERMINAL APPLICATION SPECIFICATION	114-2036		
TERMINALS APPLIED			
TE TERMINAL	TE TERMINAL	TE TERMINAL	TE TERMINAL
1217129-1	63372-1	62138-1	62138-2
62138-3			

WIRE SIZE	CRIMP HEIGHT mm [INCH]	CRIMP HEIGHT REFERENCE SETTING
20 AWG OR 0.52mm2	1.22+/-0.05 [1.048+/-0.002]	2.8
22 AWG OR 0.32mm2	1.09+/-0.05 [1.043+/-0.002]	4.1
24 AWG OR 0.25mm2	1.02+/-0.05 [1.040+/-0.002]	4.8

- 1 RECOMMENDED SPARE PARTS
- 2 REFER TO SUPPLIED INSTRUCTION SHEET FOR CLEANING, LUBRICATION AND STORAGE OF APPLICATOR.
- 3 APPLY PART NUMBER 2-23419-6 LOCTITE TO THREADS OF ITEM 242. APPLY PART NUMBER 1-23419-5 LOCTITE TO THREADS OF ITEM 50.
- 4 CRIMP HEIGHT REFERENCE SETTING WAS THE SETTING USED WHEN THE APPLICATOR WAS QUALIFIED AT THE FACTORY. ADJUSTMENT MAY BE NECESSARY WHEN RUNNING APPLICATOR IN THE FIELD.
- 5. UNLESS SPECIFIED OTHERWISE TORQUE VALUES SHALL BE USED PER DOCUMENT, 101-35000.
- 6 TERMINAL LUBRICANT IS RECOMMENDED.

***WARNING**
ON INSTALLATION, SET WIRE DISC TO CRIMP HEIGHT REFERENCE SETTING FOR LARGEST WIRE SIZE. CRIMP HEIGHT REFERENCE SETTINGS GREATER THAN THE VALUE SHOWN MAY CAUSE DAMAGE TO THE CRIMP TOOLING. REFER TO THE INSTRUCTION SHEET FOR PROPER SETUP AND ADJUSTMENTS.

ATLANTIC VERSION
Shown on sheets 1 of 4 & 2 of 4
(Pacific version shown on sheets 3 of 4 & 4 of 4)

LOC	DIST	REVISIONS					
		P	LTN	DESCRIPTION	DATE	DWN	APVD
A	66	B		ECR-16-004882	04APR2016	MR	GB
		C		ECR-17-013340	11SEP2017	TB	TE
		D		ECR-21-004881	27APR2021	TB	RK
		E		ECR-21-116312	06OCT2021	JWC	TE

-	1	-	1	-	2119641-1	FEED CAM, AIR FEED	248	
-	1	1	1	1	2119082-9	CAM, SNAIL, INSULATION ADJUSTMENT	244	
-	1	1	1	1	2079764-1	WASHER, WAVE SPRING, CREST-TO-CREST	243	
3	-	1	1	1	2119083-1	RETAINER, INSULATION DIAL	242	
-	-	1	-	1	2119580-1	MECHANICAL FEED ASSEMBLY	239	
-	1	-	1	-	2844940-3	AIR FEED MODULE	238	
-	1	1	1	1	1-18028-0	WASHER, FLAT, REG M8	192	
-	1	1	1	1	6-993111-6	PIN, SLOTTED SPRING 3.0 X 14.0	177	
-	1	1	1	1	8-22280-7	SPRING, COMPRESSION	176	
-	1	1	1	1	1752353-2	GUIDE PIN,HOLDDOWN	175	
-	1	1	1	1	1901680-2	GUIDE PIN,HOLDDOWN	174	
-	REF	REF	REF	REF	994970-2	COUNTER, MAGNETIC	164	
6	-	1	1	1	2119955-2	ASSY, LUBRICATOR, END FEED	84	
-	1	1	1	1	455888-5	SPACER, CRIMPER	82	
-	1	1	1	1	2119791-5	DEPRESSOR, WIRE	73	
-	1	1	1	1	1803607-4	DOCUMENTATION PACKAGE	71	
-	2	2	2	2	2-18032-2	SCR, SET, FLT PNT, M3 X 10.0	70	
-	1	1	1	1	2119740-1	TAG, IDENTIFICATION	67	
-	2	2	2	2	2168078-1	SCREW, DRIVE, RH, RoHS, 2 x .188	66	
-	1	1	1	1	1-1901681-8	HOLDDOWN, TERMINAL	65	
-	2	2	2	2	2168400-5	SHCS, LOW HEAD, RoHS, M4 X 20	64	
-	1	1	1	1	2168083-2	SCR, SKT HD CAP, RoHS, M4 X 8.0	60	
-	1	1	1	1	5-18022-5	SCR, HEX HD CAP, M4 X 6.0	59	
-	-	1	-	1	2063961-1	FEED FINGER	58	
-	3	3	3	3	2168400-4	SHCS, LOW HEAD, RoHS, M4 X 8	57	
-	2	2	2	2	2168083-2	SCR, SKT HD CAP, RoHS, M4 X 8.0	56	
-	2	2	2	2	5018030-1	NUT, HEX, REG, RoHS, M3	54	
-	2	2	2	2	986965-8	NUT, LOCK, HEX, TORQUE (M4)	53	
-	1	1	1	1	1-5018030-0	NUT, HEX, REG, RoHS, M3.5	52	
-	1	-	1	-	2063961-1	FEED FINGER	51	
3	-	1	1	1	1752354-5	STANDOFF,HOLD-DOWN	50	
-	1	2	1	2	18023-9	SCR, SKT HD CAP M4 X 6.0	49	
-	-	1	-	1	2119652-1	FEED CAM, PRE FEED	48	
-	-	1	-	1	2119653-1	FEED CAM, POST FEED	47	
-	1	1	1	1	2119655-5	APPLICATOR BASIC ASSEMBLY, EF	46	
-	1	1	1	1	1803517-1	RAM ASSEMBLY, EF ATLANTIC	44	
-	1	1	1	1	1803602-1	SCR, BHSC, RoHS (M8 X 25)	41	
-	7	7	7	7	1-18028-2	WASHER, FLAT, REG M4	33	
-	2	2	2	2	2168083-9	SCR, SKT HD CAP, RoHS, M4 X 20	31	
-	2	2	2	2	2168083-2	SCR, SKT HD CAP, RoHS, M4 X 8.0	29	
-	1	1	1	1	240639-1	STRIPPER (MACHINING)	27	
-	2	2	2	2	1-2168083-5	SCR, SKT HD CAP, RoHS, M4 X 30	25	
-	1	1	1	1	1752371-5	PLATE, STRIP GUIDE	24	
-	1	1	1	1	240825-7	PLATE, STRIP HOLD DOWN	23	
-	2	2	2	2	2-22281-3	SPRING, COMPRESSION	22	
-	1	1	1	1	1803292-4	DRAG	20	
-	2	2	2	2	1901259-5	GUIDE, LOWER STRIP	18	
-	4	4	4	4	1-2079383-1	SCR, BHSC, RoHS (M6 X 12)	17	
-	1	1	1	1	1752360-1	SPACER,HOLD-DOWN	13	
1	-	1	1	1	240644-1	PLATE, REAR SHEAR	11	
-	-	-	-	-	-	-	10	
1	-	1	1	1	690482-6	PLATE, FRONT SHEAR	9	
1	1	2	2	1	1	3-1803000-7	ANVIL, COMBINATION, END FEED	8
1	-	1	1	1	1	2217206-4	BLADE, SLUG	7
-	-	-	-	-	-	-	6	
-	1	1	1	1	1	240641-5	SPACER	5
-	1	1	1	1	1	238011-2	BLOCK, CRIMPER SPACER	4
1	1	2	2	1	1	5-2119582-2	CRIMPER, INSULATION F PREMIUM	3
-	1	1	1	1	1	455888-1	SPACER, CRIMPER	2
1	1	2	2	1	1	456402-2	CRIMPER, WIRE PREMIUM	1
-	77	72	71	2	-1	PART NO	DESCRIPTION	ITEM NO

DIMENSIONS:		TOLERANCES UNLESS OTHERWISE SPECIFIED:		DWN R. STAKEM CHK G. BAILEY APVD T. ELBIN		18OCT2013 18OCT2013 18OCT2013		NAME Ocean End Feed Applicator	
mm		0 PLC ± 1 PLC ± 2 PLC ± 3 PLC ± 4 PLC ± ANGLES ± FINISH		PRODUCT SPEC		SIZE A1		CAGE CODE 00779	
MATERIAL				APPLICATION SPEC		DRAWING NO 2150383		RESTRICTED TO	
				WEIGHT		SCALE 1:1		SHEET 1 OF 4	
				Customer Accessible Production Drawing		REV E			

LOC	DIST	REV	DESCRIPTION	DATE	OWN	APVD
A	66		SEE SHEET 1			

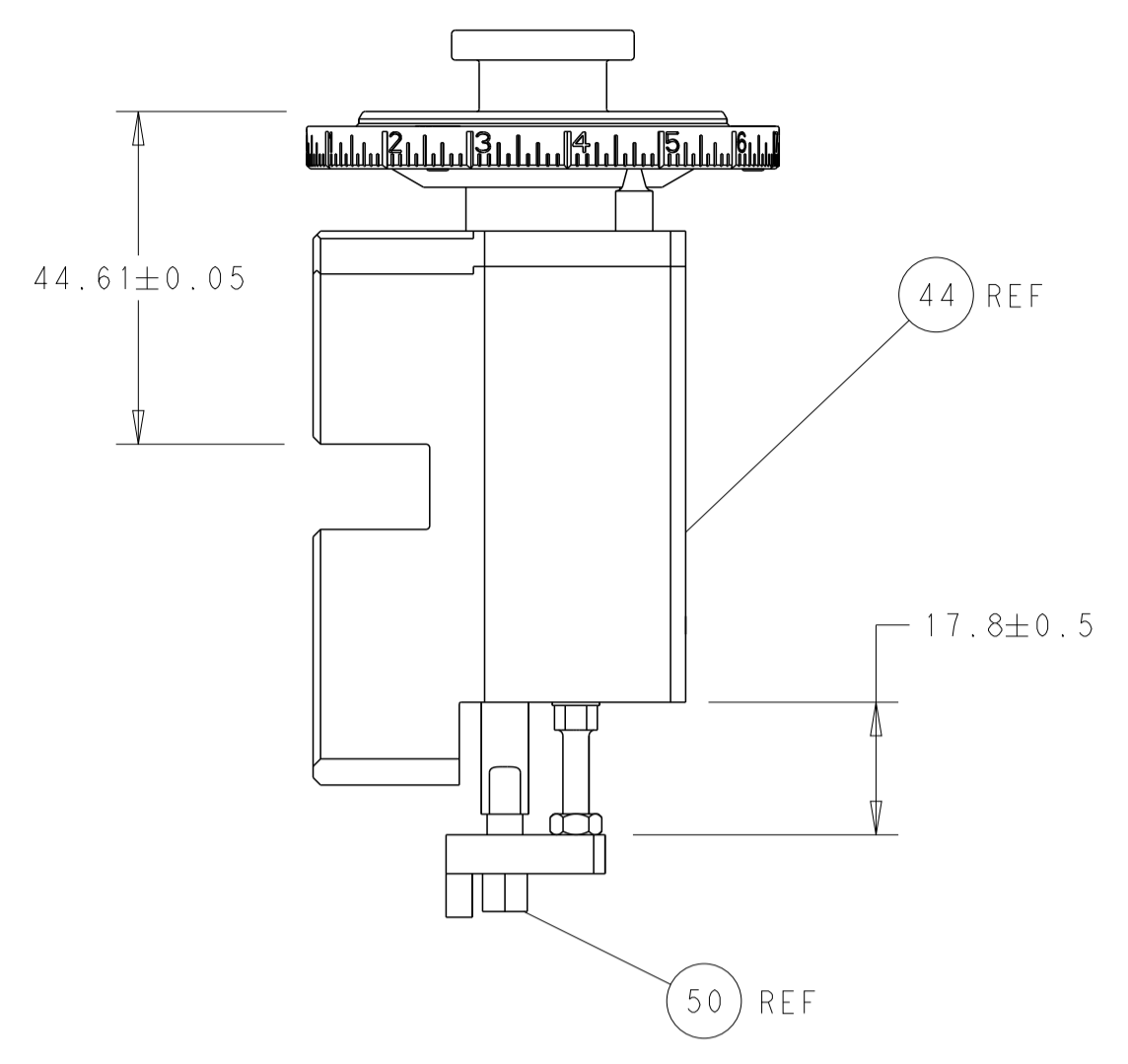

RAM & HOLDDOWN SET-UP

FEED TYPE
MECHANICAL

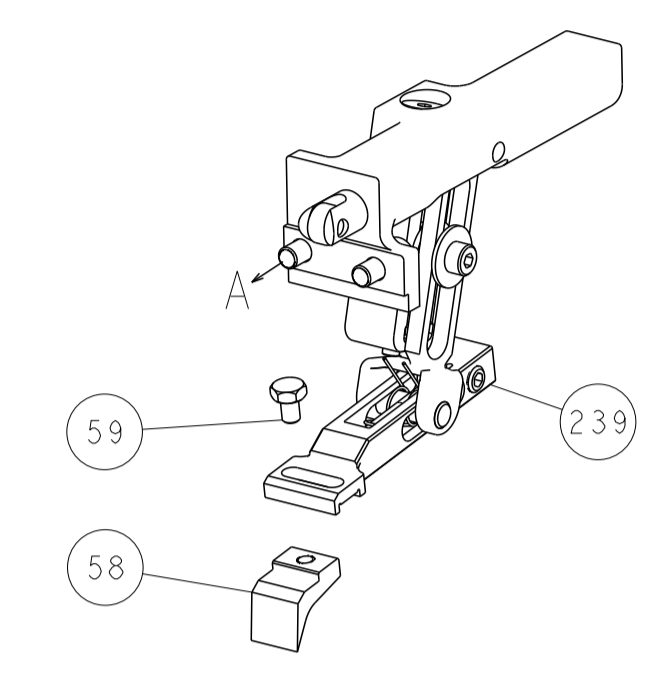

PNEUMATIC

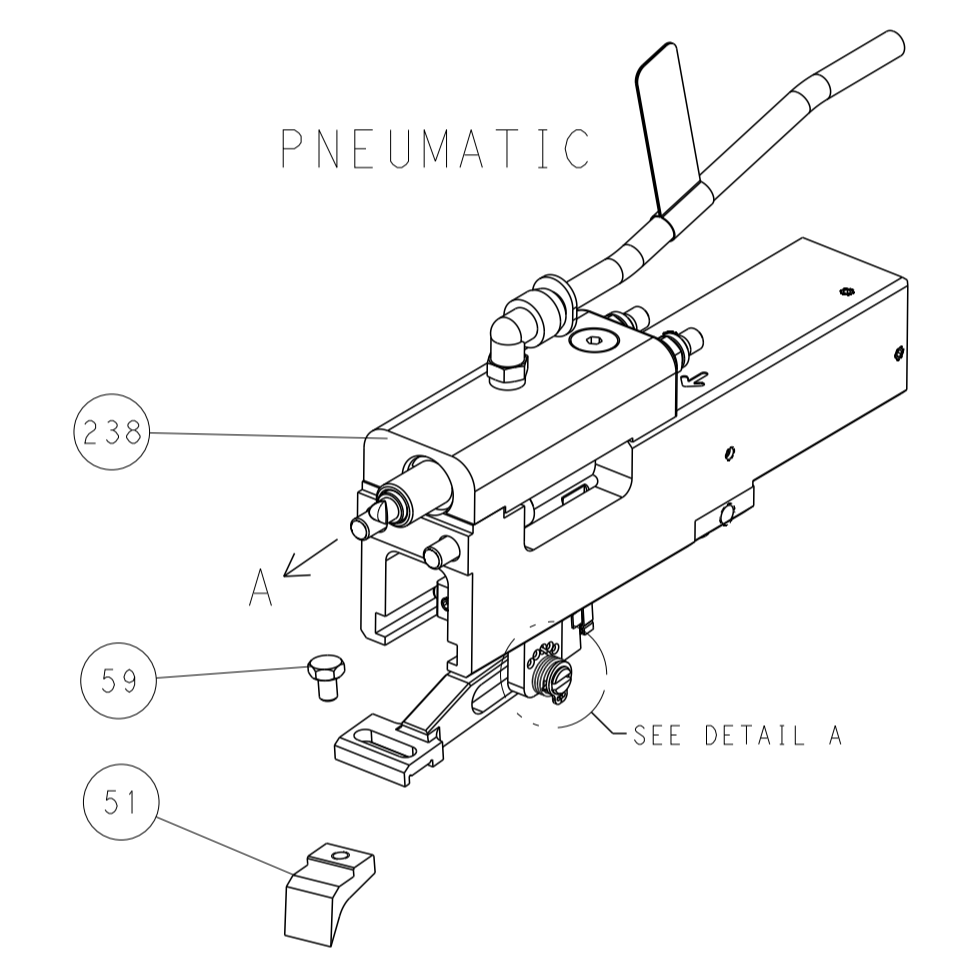

FEED SPRING
SETTING POSITION

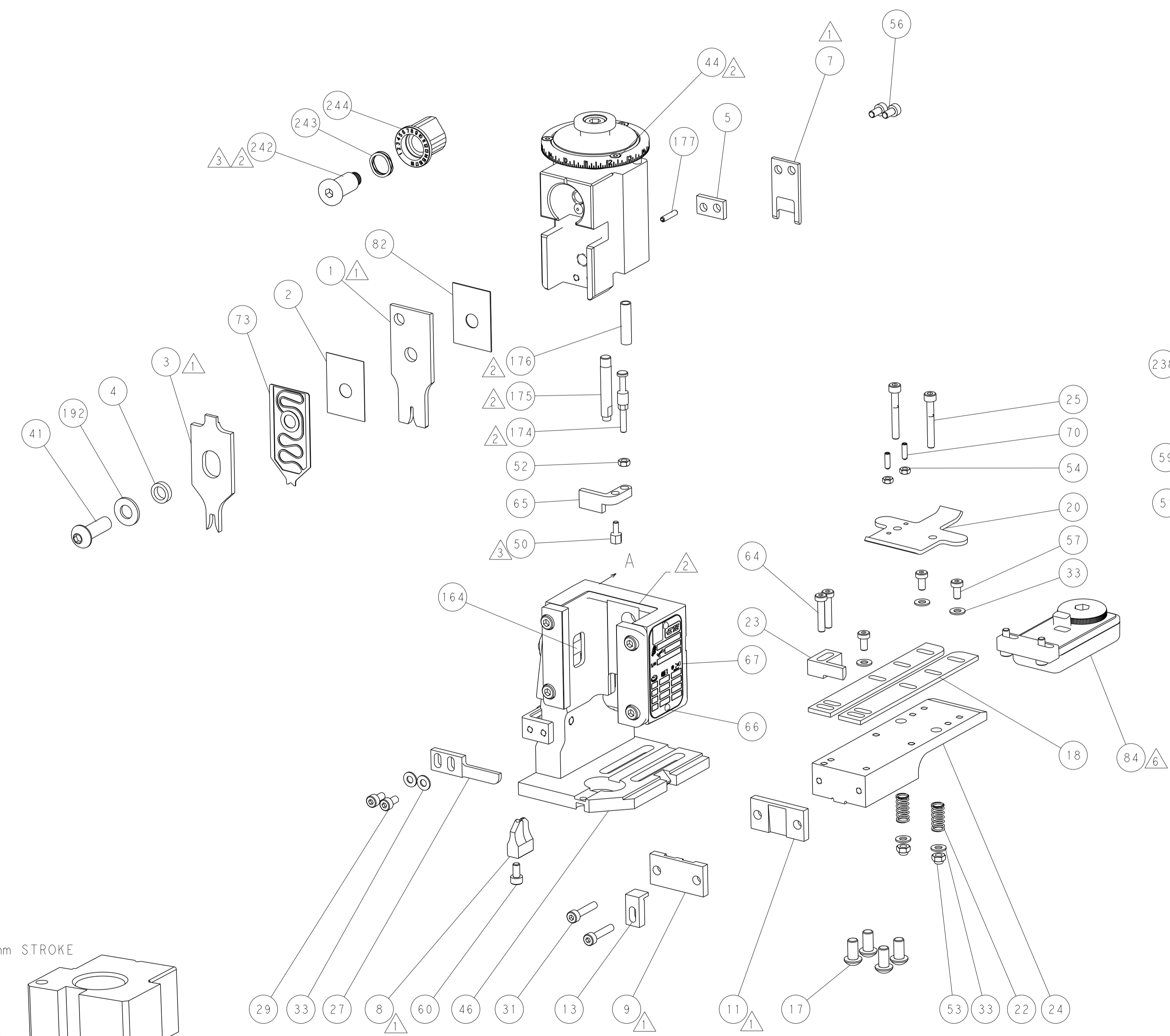
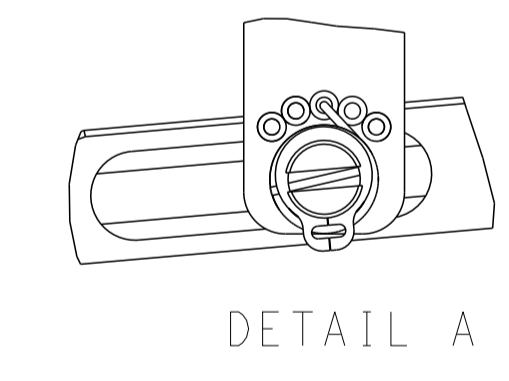

CAM POSITIONS

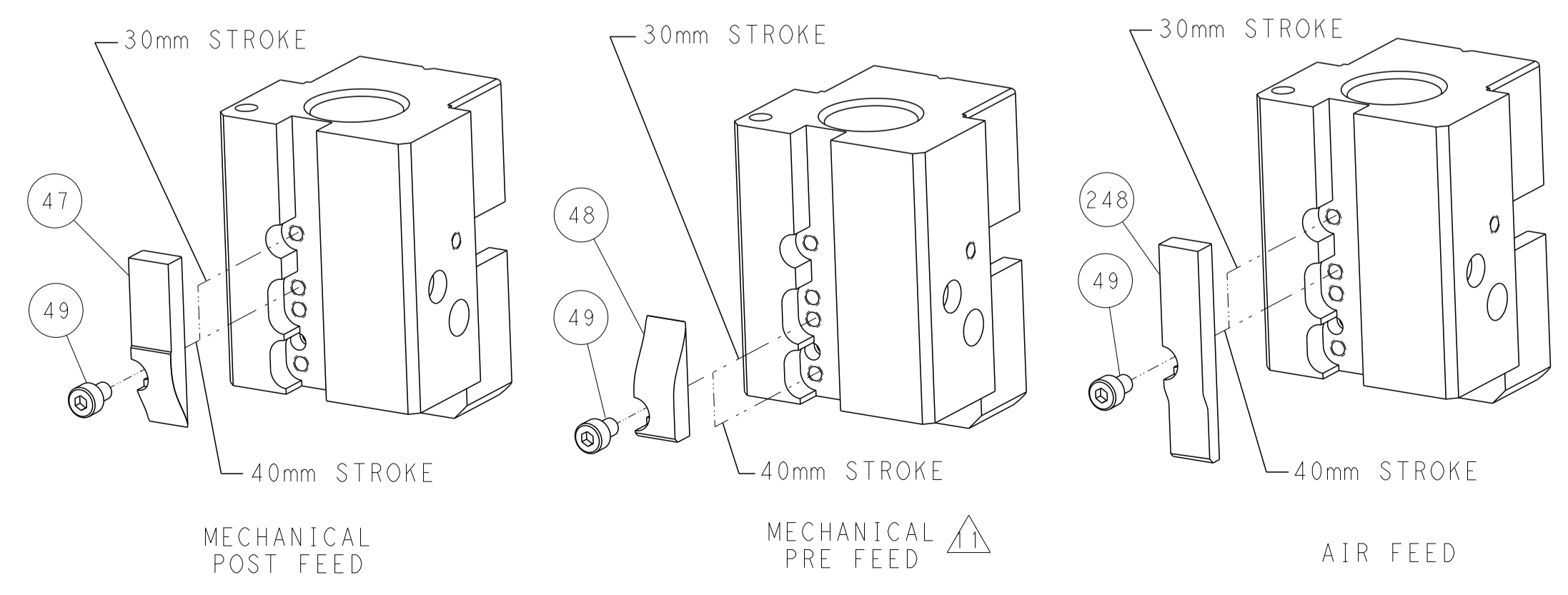

ATLANTIC VERSION
 Shown on sheets 1 of 4 & 2 of 4
 (Pacific version shown on sheets 3 of 4 & 4 of 4)

<small>THIS DRAWING IS UNPUBLISHED. RELEASED FOR PUBLICATION BY TYCO ELECTRONICS CORPORATION. ALL RIGHTS RESERVED.</small>		DWN: K. STAKEM CHK: G. BAILEY APVD: T. ERLIN	18OCT2013 18OCT2013 18OCT2013	TE Connectivity Harrisburg, PA 17105-3608
DIMENSIONS: mm TOLERANCES UNLESS OTHERWISE SPECIFIED: 0 PLC ± 1 PLC ± 2 PLC ± 3 PLC ± 4 PLC ± ANGLES ± FINISH		NAME: Ocean End Feed Applicator SIZE: A1 CAGE CODE: 00779 DRAWING NO: 2150383		RESTRICTED TO:
MATERIAL:		WEIGHT:		SCALE: 1:1 SHEET: 2 of 4 REV: E

THIS DRAWING IS UNPUBLISHED.	RELEASED FOR PUBLICATION		
COPYRIGHT © BY TYCO ELECTRONICS CORPORATION. ALL RIGHTS RESERVED.			
PART NUMBER	REVISION	DESCRIPTION	FEED TYPE
2-2150383-1	E	FINE CRIMP HEIGHT ADJUST	MECHANICAL
2-2150383-2	E	FINE CRIMP HEIGHT ADJUST	PNEUMATIC
7-2150383-7	A	CRIMP TOOLING KIT	-

PACIFIC VERSION TERMINATOR
INTERFACE ADAPTER

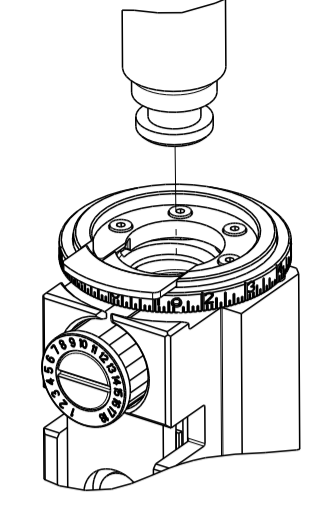

APPLICATOR DATA		
CRIMP	SIZE	TYPE
WIRE	.055 [1.40 mm]	F
INSUL	.140 [3.56 mm]	F
APPL INSTRUCTIONS 408-35043		

TERMINAL DATA: TE TERMINAL		TE CRIMP SPECIFICATION	
TERMINAL NAME: RECEPTACLE, FASTON, .187 SERIES			
WIRE STRIP LENGTH .153-.168 IN [3.87-4.25 mm]		INSULATION DIAMETER RANGE Ø.060-.110 IN [1.52-2.79 mm]	
TERMINAL APPLICATION SPECIFICATION	114-2036	-	-
TERMINALS APPLIED			
TE TERMINAL	TE TERMINAL	TE TERMINAL	TE TERMINAL
1217129-1	63372-1	62138-1	62138-2
62138-3			

WIRE SIZE	CRIMP HEIGHT mm [INCH]	CRIMP HEIGHT REFERENCE SETTING
20 AWG OR 0.52mm2	1.22+/-0.05 [0.48+/-0.002]	2.8
22 AWG OR 0.32mm2	1.09+/-0.05 [0.43+/-0.002]	4.1
24 AWG OR 0.25mm2	1.02+/-0.05 [0.40+/-0.002]	4.8



- 1 RECOMMENDED SPARE PARTS
- 2 REFER TO SUPPLIED INSTRUCTION SHEET FOR CLEANING, LUBRICATION AND STORAGE OF APPLICATOR.
- 3 APPLY PART NUMBER 2-23419-6 LOCTITE TO THREADS OF ITEM 242. APPLY PART NUMBER 1-23419-5 LOCTITE TO THREADS OF ITEM 50.
- 4 CRIMP HEIGHT REFERENCE SETTING WAS THE SETTING USED WHEN THE APPLICATOR WAS QUALIFIED AT THE FACTORY. ADJUSTMENT MAY BE NECESSARY WHEN RUNNING APPLICATOR IN THE FIELD.
- 5. UNLESS SPECIFIED OTHERWISE TORQUE VALUES SHALL BE USED PER DOCUMENT, 101-35000.
- 6 TERMINAL LUBRICANT IS RECOMMENDED.

***WARNING**
ON INSTALLATION, SET WIRE DISC TO CRIMP HEIGHT REFERENCE SETTING FOR LARGEST WIRE SIZE. CRIMP HEIGHT REFERENCE SETTINGS GREATER THAN THE VALUE SHOWN MAY CAUSE DAMAGE TO THE CRIMP TOOLING. REFER TO THE INSTRUCTION SHEET FOR PROPER SETUP AND ADJUSTMENTS.

PACIFIC VERSION
Shown on sheets 3 of 4 & 4 of 4
(Atlantic version shown on sheets 1 of 4 & 2 of 4)

LOC	DIST	REVISIONS					
A	66	P	LTN	DESCRIPTION	DATE	DWN	APVD
-	-	-	-	SEE SHEET 1	-	-	-

-	1	1	2119082-9	CAM, SNAIL, INSULATION ADJUSTMENT	244
-	1	1	2079764-1	WASHER, WAVE SPRING, CREST-TO-CREST	243
3	-	1	2119083-1	RETAINER, INSULATION DIAL	242
-	-	1	2119580-1	MECHANICAL FEED ASSEMBLY	239
-	1	-	2844940-3	AIR FEED MODULE	238
-	1	1	1-18028-0	WASHER, FLAT, REG M8	192
-	4	4	2079383-9	SCR, BHSC, RoHS (M6 X 20)	186
-	1	1	6-993111-6	PIN, SLOTTED SPRING 3.0 X 14.0	177
-	1	1	8-22280-7	SPRING, COMPRESSION	176
-	1	1	1752353-2	GUIDE PIN,HOLDDOWN	175
-	1	1	1901680-2	GUIDE PIN,HOLDDOWN	174
-	REF	REF	994970-2	COUNTER, MAGNETIC	164
-	1	-	2119641-2	FEED CAM, AIR FEED	152
-	1	1	2168083-8	SCR, SKT HD CAP, RoHS, M4 X 16	144
-	-	1	2119653-2	FEED CAM, POST FEED	142
-	1	1	2119655-6	APPLICATOR BASIC ASSEMBLY, EF	141
-	1	1	1803518-1	RAM ASSEMBLY, EF PACIFIC	140
6	-	1	2119955-2	ASSY, LUBRICATOR, END FEED	84
-	1	1	455888-5	SPACER, CRIMPER	82
-	1	1	2119791-5	DEPRESSOR, WIRE	73
-	1	1	1803607-4	DOCUMENTATION PACKAGE	71
-	2	2	2-18032-2	SCR, SET, FLT PNT, M3 X 10.0	70
-	1	1	2119740-1	TAG, IDENTIFICATION	67
-	2	2	2168078-1	SCREW, DRIVE, RH, RoHS, 2 x .188	66
-	1	1	1-1901681-8	HOLDDOWN, TERMINAL	65
-	2	2	2168400-5	SHCS, LOW HEAD, RoHS, M4 X 20	64
-	1	1	5-18022-5	SCR, HEX HD CAP, M4 X 6.0	59
-	-	1	2063961-1	FEED FINGER	58
-	3	3	2168400-4	SHCS, LOW HEAD, RoHS, M4 X 8	57
-	2	2	2168083-2	SCR, SKT HD CAP, RoHS, M4 X 8.0	56
-	2	2	5018030-1	NUT, HEX, REG, RoHS, M3	54
-	2	2	986965-8	NUT, LOCK, HEX, TORQUE (M4)	53
-	1	1	1-5018030-0	NUT, HEX, REG, RoHS, M3.5	52
-	1	-	2063961-1	FEED FINGER	51
3	-	1	1752354-5	STANDOFF,HOLD-DOWN	50
-	1	2	18023-9	SCR, SKT HD CAP M4 X 6.0	49
-	-	1	2119652-1	FEED CAM, PRE FEED	48
-	1	1	1803602-1	SCR, BHSC, RoHS (M8 X 25)	41
-	7	7	1-18028-2	WASHER, FLAT, REG M4	33
-	2	2	2168083-9	SCR, SKT HD CAP, RoHS, M4 X 20	31
-	2	2	2168083-2	SCR, SKT HD CAP, RoHS, M4 X 8.0	29
-	1	1	240639-1	STRIPPER (MACHINING)	27
-	2	2	1-2168083-5	SCR, SKT HD CAP, RoHS, M4 X 30	25
-	1	1	1752371-5	PLATE, STRIP GUIDE	24
-	1	1	240825-7	PLATE, STRIP HOLD DOWN	23
-	2	2	2-22281-3	SPRING, COMPRESSION	22
-	1	1	1803292-4	DRAG	20
-	2	2	1901259-5	GUIDE, LOWER STRIP	18
-	1	1	1752360-1	SPACER,HOLD-DOWN	13
1	-	1	240644-1	PLATE, REAR SHEAR	11
-	-	-	-	-	10
1	-	1	690482-6	PLATE, FRONT SHEAR	9
1	1	1	3-1803000-7	ANVIL, COMBINATION, END FEED	8
1	-	1	2217206-4	BLADE, SLUG	7
-	-	-	-	-	6
-	1	1	240641-5	SPACER	5
-	1	1	238011-2	BLOCK, CRIMPER SPACER	4
1	1	1	5-2119582-2	CRIMPER, INSULATION F PREMIUM	3
-	1	1	455888-1	SPACER, CRIMPER	2
1	1	1	456402-2	CRIMPER, WIRE PREMIUM	1
-	77	22	21	PART NO	ITEM NO

DIMENSIONS:		TOLERANCES UNLESS OTHERWISE SPECIFIED:		DWN: H. STAKEM 180CT2013		CHK: G. BAILEY 180CT2013		APVD: T. ELBIN 180CT2013		NAME: TE Connectivity Harrisburg, PA 17105-3608	
mm	0 PLC ±	1 PLC ±	2 PLC ±	3 PLC ±	4 PLC ±	PRODUCT SPEC		APPLICATION SPEC		SIZE: A1	
MATERIAL:	FINISH:	WEIGHT:		SCALE: 1:1		SHEET: 3 OF 4		REV: E		RESTRICTED TO:	

LOC		DIST		REVISIONS			
A	66	P	LTN	DESCRIPTION	DATE	DWN	APVD
		-		SEE SHEET 1	-	-	-

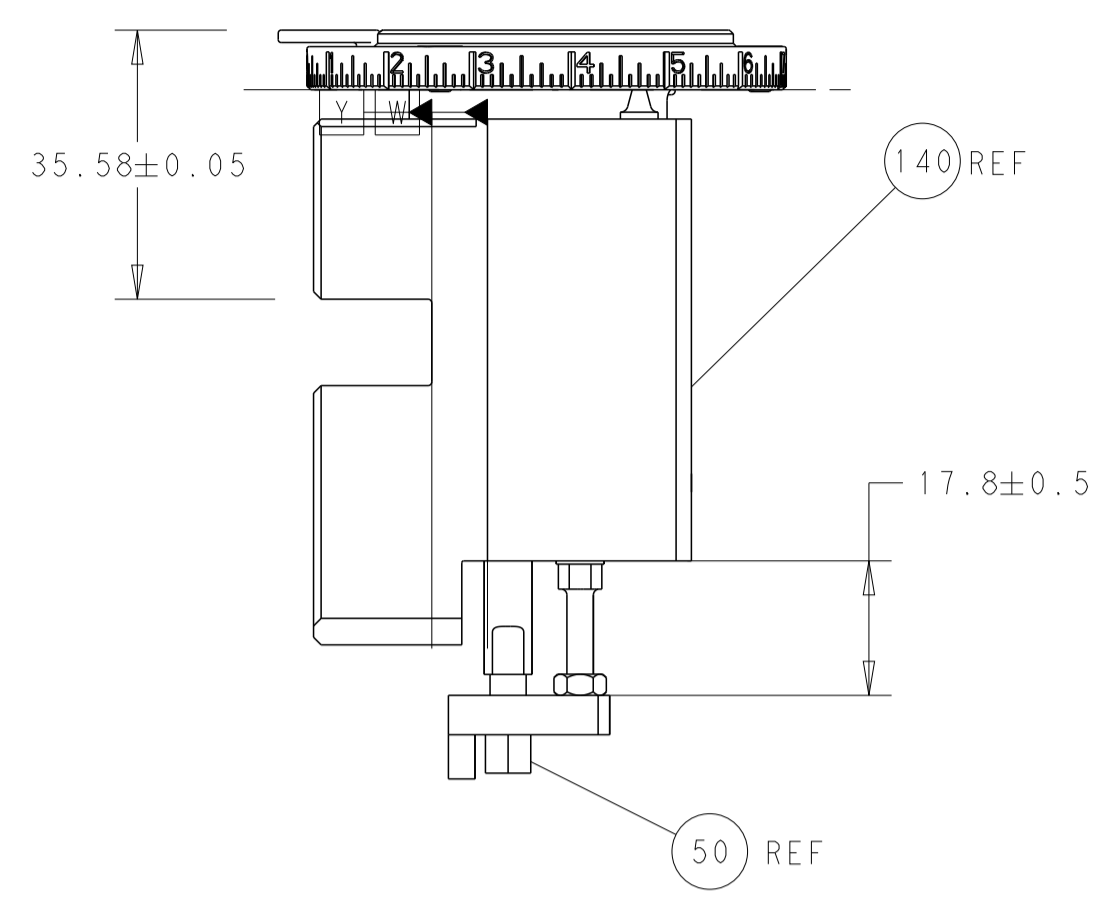

RAM & HOLDDOWN SET-UP

FEED TYPE
MECHANICAL

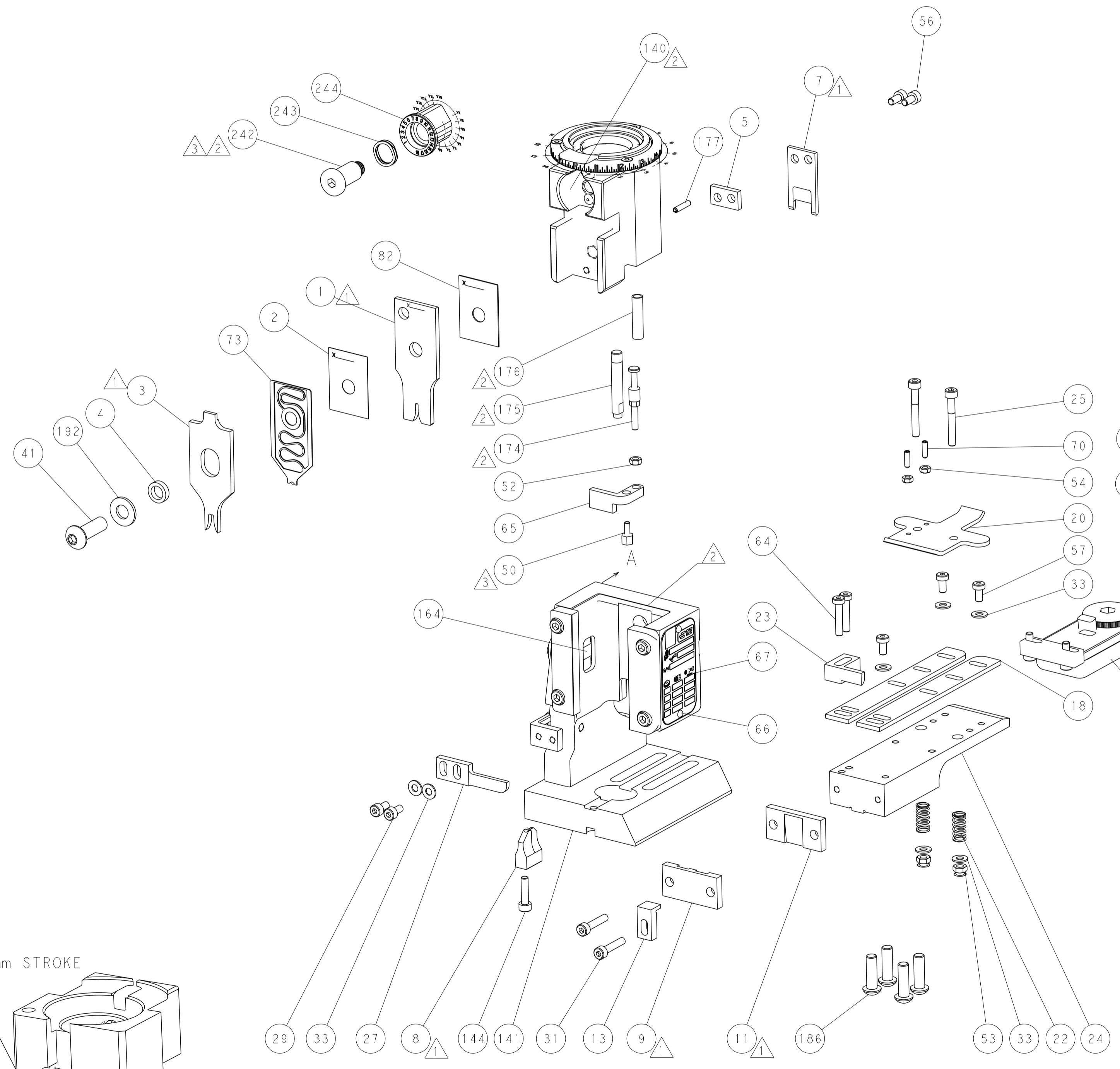
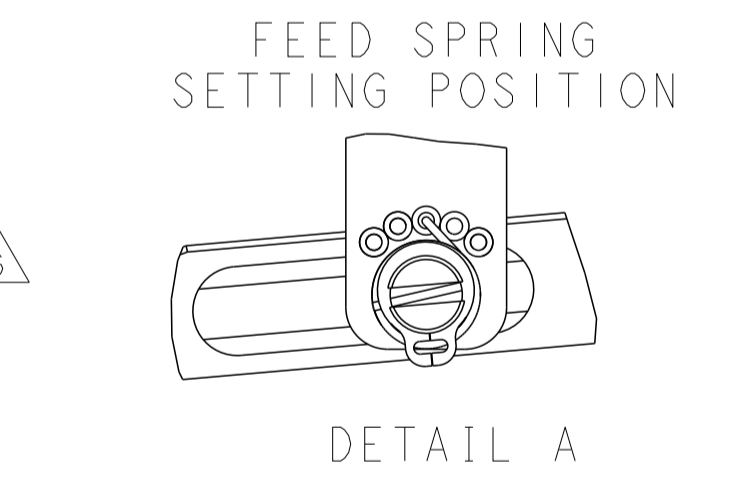
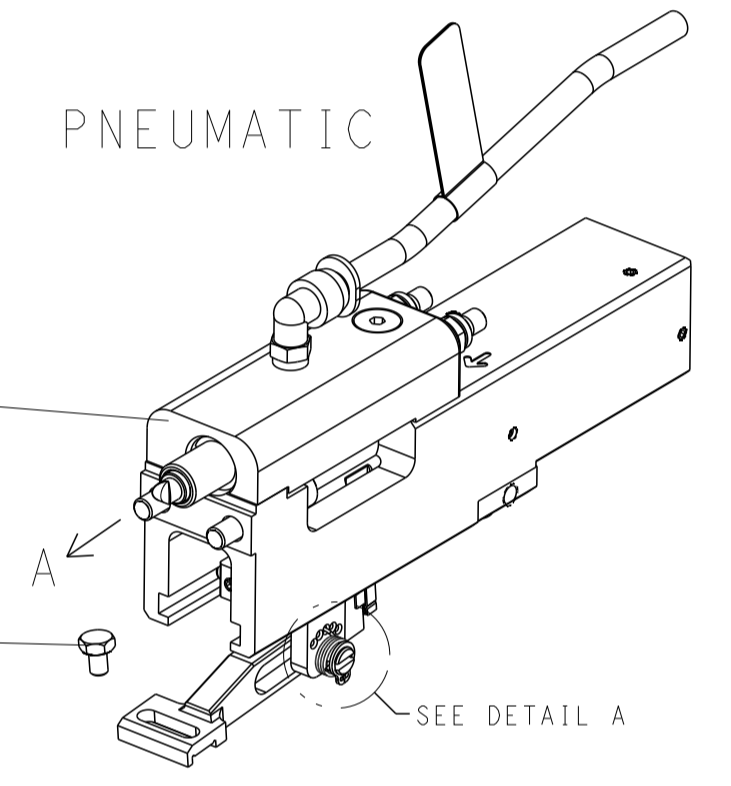
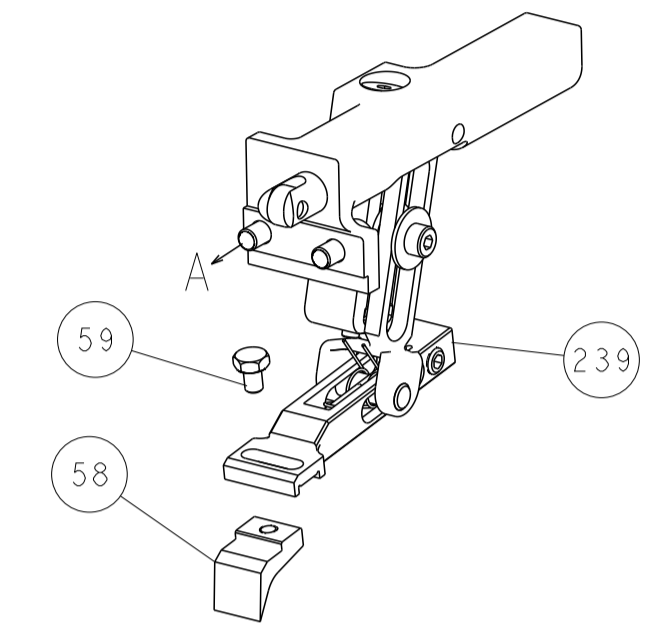

CAM POSITIONS

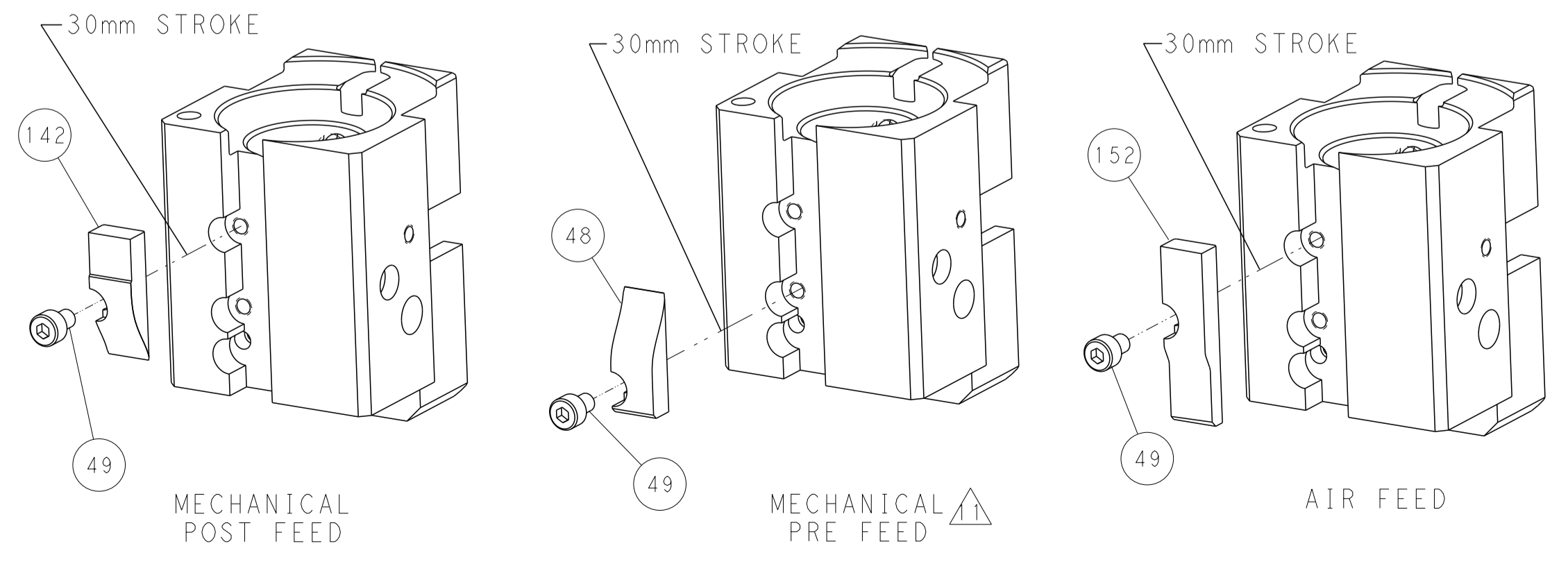

PACIFIC VERSION
 Shown on sheets 3 of 4 & 4 of 4
 (Atlantic version shown on sheets 1 of 4 & 2 of 4)

DIMENSIONS:		TOLERANCES UNLESS OTHERWISE SPECIFIED:		DWN		18OCT2013		STE TE Connectivity	
mm		0 PLC ±		CHK		18OCT2013		Harrisburg, PA 17105-3608	
Ø		1 PLC ±		G. BAILEY		18OCT2013		NAME	
H		2 PLC ±		T. ERLIN		18OCT2013		Ocean End Feed	
D		3 PLC ±		PRODUCT SPEC				Applicator	
R		4 PLC ±		APPLICATION SPEC				SIZE	
ANGLES		5 PLC ±		WEIGHT		A		CAGE CODE	
FINISH		6 PLC ±		MATERIAL		00779		DRAWING NO	
		7 PLC ±		SCALE		1:1		SHEET	
		8 PLC ±		RESTRICTED TO		Customer Accessible Production Drawing		4 OF 4	
		9 PLC ±		REV		E			