

Switching Power Supply Type SPD 18W DIN rail mounting

CARLO GAVAZZI



- Universal AC input full range
- Installation on DIN rail 7.5 or 15mm
- Short circuit protection
- Overload protection
- High efficiency
- LED indicator for DC power ON
- LED indication for DC low
- Internal input filter
- CE, TUV approved and cULus Listed

Product Description

The Switching power supplies and compact dimensions and performance are a must. designed to be used in all automation application where the installation is on a DIN rail

Ordering Key

SP D 24 18 1 B

Model _____
 Mounting (D = Din rail) _____
 Output voltage _____
 Output power _____
 Input Type _____
 Optional features _____

Input type: 1= single phase

Approvals



UL US C **UL** US C **UL** US
 Class I, Div 2 UL 1310 UL 60950-1

Optional Features

Description	Code
Spring connectors	B

Output performances

MODEL NO.	INPUT VOLTAGE	OUTPUT WATTAGE	OUTPUT VOLTAGE	OUTPUT CURRENT	EFF. (min.)	EFF. (typ.)
Single Output Models						
SPD05	90~264 VAC	15 WATTS	+ 5 VDC	3000 mA	73%	75%
SPD12	90~264 VAC	18 WATTS	+12 VDC	1500 mA	75%	77%
SPD15	90~264 VAC	18 WATTS	+15 VDC	1200 mA	75%	77%
SPD24	90~264 VAC	18 WATTS	+24 VDC	750 mA	75%	77%

Output data

Line regulation	± 1%	Rated continuous loading	5V Model	3A @ 5VDC/2.6A @ 5.75VDC
Load regulation	± 2%		12V Model	1.5A @ 12VDC/1.3A @ 13.8VDC
Minimum load	0	15V Model	1.2A @ 15VDC/1.0A @ 17.25VDC	
Turn on time (full resistive load)	1000ms	24V Model	0.75A @ 24VDC/0.6A @ 28.8VDC	
Vi nom, Io nom with 7000µF CAP	1500ms	Reverse voltage	5V Model	VDC 7.5
Transient recovery time	2ms	12V Model	VDC 18	
Ripple and noise	50mVpp	15V Model	VDC 22	
Output voltage accuracy	± 1%	24V Model	VDC 35	
Temperature coefficient	± 0.03%/°C	Capacitor load	7000µF	
Hold up time Vi= 115VAC	20ms	Voltage rise time		
Vi= 230VAC	75ms	Vi nom Io nom	150ms	
Voltage fall time (I _o nom)	150ms max	Vi nom, Io nom with 7000µF CAP	500ms	

Input data

Rated input voltage	100 - 240VAC	Power dissipation (Vi : 230VAC, Io nom)	5V Model 5.0W 12V Model 4.65W 15V Model 4.25W 24V Model 4.45W
Voltage range	AC 90 - 264VAC DC 120 - 375VDC	Frequency range	47- 63Hz
Rated input current Vi: 115VAC, Io nom	335-500mA	Leakage current	Input-Output 0.25mA Input-FG 3.5mA
Inrush current	Vi= 115VAC 10A Vi= 230VAC 18A		

Controls and Protections

Overload	110 – 140%	Output Short Circuit	Hiccup mode
Input Fuse Overvoltage Protection	T2A/250VAC internal ¹⁾ 125 – 145%	Internal surge voltage protection (IEC 61000-4-5)	Varistor

¹⁾ Fuse not replaceable by user

General data (@ nominal line, full load, 25°C)

Ambient temperature	-20°C to 71°C	MTBF (Bellcore issue 6 @ 40°C, GB)	5V Model 795000 Hours 12V Model 797000 Hours 15V Model 796000 Hours 24V Model 800000 Hours
Derating (>61°C to +71°C)	2.5%/°C	Case material	Plastic: PC, UL94-V0
Ambient humidity	20 ~ 95%RH	Pollution degree	2
Storage	-25°C to +85°C	Altitude	2000m
Protection degree	IP20	Dimensions LxWxD mm(inch)	90(3.60)x22.5(0.89)x114(4.49)
Cooling	Free air convection	Weight	150g
Insulation voltage	Input-Output 3.000VAC/4242VDC min Input-FG 1.500VAC/2121VDC min		
Insulation resistance I/O	100MΩ min (@ 500VDC)		

Norms and Standards

Vibration resistance	meet IEC 60068-2-6 (Mounting by rail: 10-500Hz, 2G, along X, Y, Z each Axis, 60 min for each Axis)	CE	EN 61000-6-3, EN 55022 Class B, EN 61000-3-2, EN 61000-3-3, EN 61000-6-2, EN 55024, EN 61000-4-2 Level 4, EN 61000-4-3 Level 3, EN 61000-4-4 Level 4, EN 61000-4-5 L-N Level 3, L/N-FG Level 4, EN 61000-4-6 Level 3, EN 61000-4-8 Level 4, EN 61000-4-11, ENV 50204 Level 2, EN 61204-3
Shock resistance	meet IEC 60068-2-27 (15G, 11ms, 3 Axis, 6 faces, 3 times for each face)		
UL / cUL	UL508 listed, UL60950-1, UL1310 Class 2 Power (only 5V, 12V w/o Class 2) Recognized, ISA 12.12.01 (Class 1, Division 2, Groups A, B, C and D)		
TUV	EN 60950-1, CB scheme		
CCC	GB4943, GB9254, GB17625.1		

Block diagrams

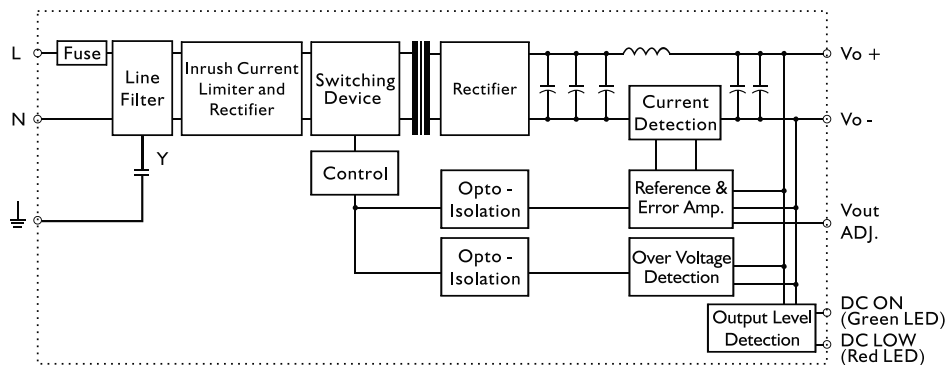

Pin Assignment and Front Controls

Pin No.	Designation	Description
1	V+	Positive output terminal
2	V-	Negative output terminal
3		Ground this terminal to minimize high-frequency emission
4	N	Input terminals (neutral conductor, no polarity at DC input)
5	L	Input terminals (phase conductor, no polarity at DC input)
	ON	Operation indicator LED
	LO	DC LOW indicator LED
	Vout ADJ.	Trimmer-potentiometer for Vout adjustment

Derating Diagram

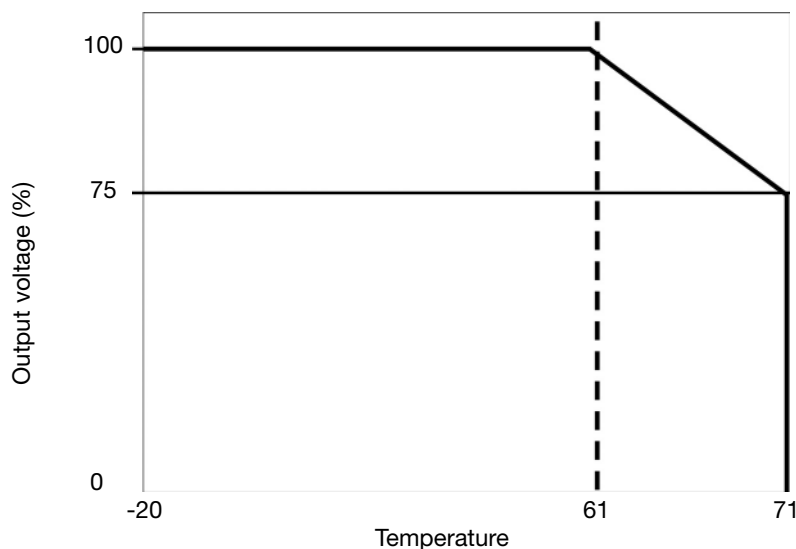

Typ. Current Limited Curve

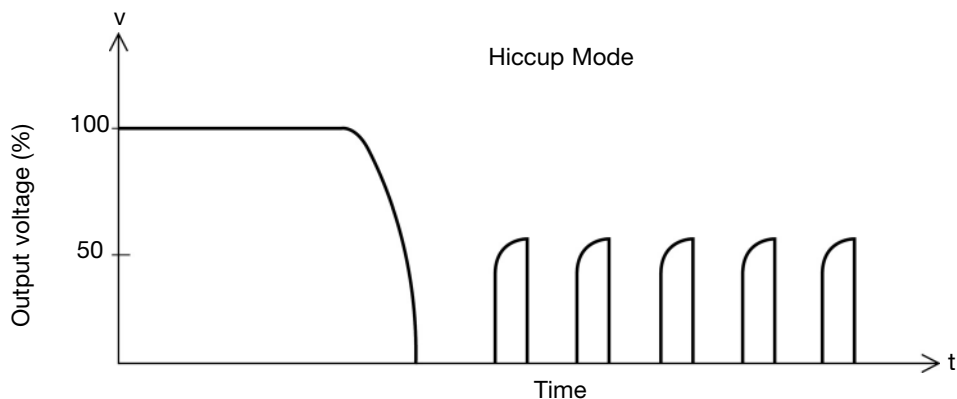

Mechanical Drawings mm (inches)

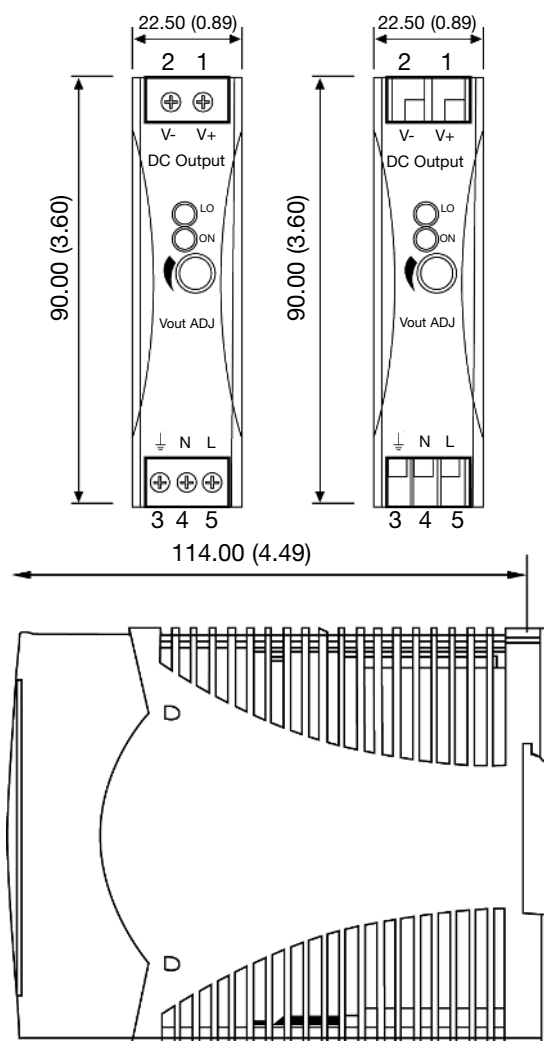

Typ. Efficiency Curve

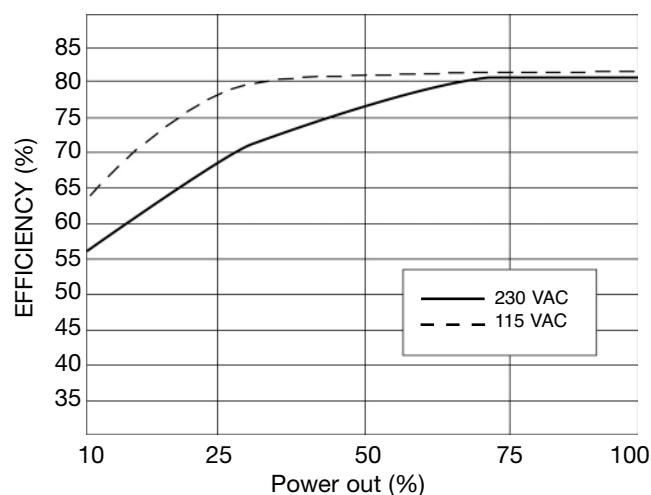

Installation

Ventilation and cooling	Normal convection All sides 25mm free space for cooling is recommended
Connector size range	AWG24-14 (0.2~2mm ²) flexible/solid cable, 10mm stripping at cable and recommends use copper conductors only, 60/75°C
Spring terminal	
Screw terminal	AWG26-12 (0.2~2.5mm ²) flexible/solid cable, connector can withstand torque at max 0,56Nm (5 lbs-in). 4~5 mm stripping at cable and recommends use copper conductors only, 60/75°C
Max. torque for terminal	
Input terminals	0.56Nm (5.0lb-in)
Output terminals	0.56Nm (5.0lb-in)
General tolerances mm(in.)	
0.00 (0.00) ÷ 30.00 (1.18)	±0.30 (0.01)
30.00 (1.18) ÷ 120.00 (4.72)	±0.50 (0.02)