

EV-T2M3SE24-3AC32A-0,7M6,0E10 - Infrastructure charging socket



1405216

<https://www.phoenixcontact.com/us/products/1405216>

Please be informed that the data shown in this PDF document is generated from our online catalog. Please find the complete data in the user documentation. Our general terms of use for downloads are valid.



CHARX connect, Infrastructure charging socket, for charging electric vehicles (EV) with alternating current (AC), Type 2, IEC 62196-2, 32 A / 480 V (AC), Single wires, length: 0.7 m, locking actuator: 24 V, 4-pos., Rear panel mounting, PHOENIX CONTACT logo

Product description

Infrastructure charging socket for charging electric vehicles (EV) with alternating current (AC), compatible with type 2 Infrastructure Plugs, for installation at charging stations for E-Mobility (EVSE)

Your advantages

- Complete product range
- Uniform, space-saving installation space
- Available with your logo on request – for consistent branding of your charging station
- Integrated interlock during charging
- Manual emergency release of the locking actuator
- Developed and produced in accordance with the IATF 16949 automotive standard and ISO 9001

Commercial data

Item number	1405216
Packing unit	1 pc
Minimum order quantity	1 pc
Note	Made to order (non-returnable)
Sales key	EM01
Product key	XWBADC
Catalog page	Page 36 (C-7-2019)
GTIN	4046356738491
Weight per piece (including packing)	656.4 g
Weight per piece (excluding packing)	0.56 g
Customs tariff number	85444290
Country of origin	DE

EV-T2M3SE24-3AC32A-0,7M6,0E10 - Infrastructure charging socket



1405216

<https://www.phoenixcontact.com/us/products/1405216>

Technical data

Product properties

Product type	Infrastructure charging socket
Product family	CHARX connect
Application	for charging electric vehicles (EV) with alternating current (AC) compatible with infrastructure charging plugs
Affixed logo	PHOENIX CONTACT logo
Charging standard	Type 2
Charging mode	Mode 3, Case B

Electrical properties

Type of signal transmission	Pulse width modulation
Note on the connection method	Crimp connection, cannot be disconnected
Type of charging current	AC 3-phase
Charging power	26.6 kW
Charging current	32 A

Power contact

Number	5 (L1, L2, L3, N, PE)
Rated voltage	480 V AC
Rated current	32 A

Signal contact

Number	2 (CP, PP)
Rated voltage	30 V AC
Rated current	2 A

Locking actuator

Operating voltage	24 V
Note number of positions	4-pos.
Position of the locking actuator	top center

Locking actuator

Operating voltage	24 V
Note number of positions	4-pos.
Position of the locking actuator	top center
Possible power supply range at the motor	22 V ... 26 V
Maximum voltage for locking detection	30 V
Typical motor current for locking	0.05 A
Reverse current of the motor	max. 0.5 A
Max. dwell time with reverse current	1 s
Recommended adaptation time	600 ms
Pause time after entry or exit path	3 s

EV-T2M3SE24-3AC32A-0,7M6,0E10 - Infrastructure charging socket



1405216

<https://www.phoenixcontact.com/us/products/1405216>

Service life insertion cycles	> 10000 load cycles
Lock recognition	available
Mechanical emergency release	available
Ambient temperature (operation)	-30 °C ... 50 °C
Cable length	0.5 m
Cable structure	4 x 0.5 mm ²
Bending radius	min. 15 mm
External cable diameter	1.6 mm ±0.02 mm
Cable weight	7 kg/km
Cable resistance	≤ 37.1 Ω/m
Single wire, color	BU/RD, BU/GN, BU/YE, BU/BN

Cable/line

Cable length	0.7 m (AC cables)
	0.5 m (Locking actuator cables)
Cable type	Single wires
Cable structure	5x 6.0 mm ² + 2x 0.5 mm ²

Mechanical properties

Mechanical data

Insertion/withdrawal cycles	> 10000
Insertion force	< 100 N
Withdrawal force	< 100 N

Environmental and real-life conditions

Ambient conditions

Ambient temperature (operation)	-30 °C ... 50 °C
Ambient temperature (storage/transport)	-40 °C ... 80 °C
Altitude	5000 m (above sea level)

Standards and regulations

Standards

Standards/regulations	IEC 62196-2
-----------------------	-------------

Mounting

Mounting type Infrastructure charging socket	Rear panel mounting (0 to 90 degree frontal inclination possible)
	Front mounting (only possible when the locking actuator is removed (see EV-T2M3SE...E00 versions))
Mounting type Protective cover	rear (available separately)
Max. wall thickness	max. 50 mm (Rear panel mounting, normative maximum specification for infrastructure plug)
	max. 28 mm (Rear mounting, normative maximum specification for infrastructure plug when using protective cover 1405217)

EV-T2M3SE24-3AC32A-0,7M6,0E10 - Infrastructure charging socket



1405216

<https://www.phoenixcontact.com/us/products/1405216>

	max. 10 mm (Front mounting, when using the locking mechanism)
Mounting hole diameter	7.00 mm (ø)

EV-T2M3SE24-3AC32A-0,7M6,0E10 - Infrastructure charging socket

1405216

<https://www.phoenixcontact.com/us/products/1405216>

Drawings

Schematic diagram

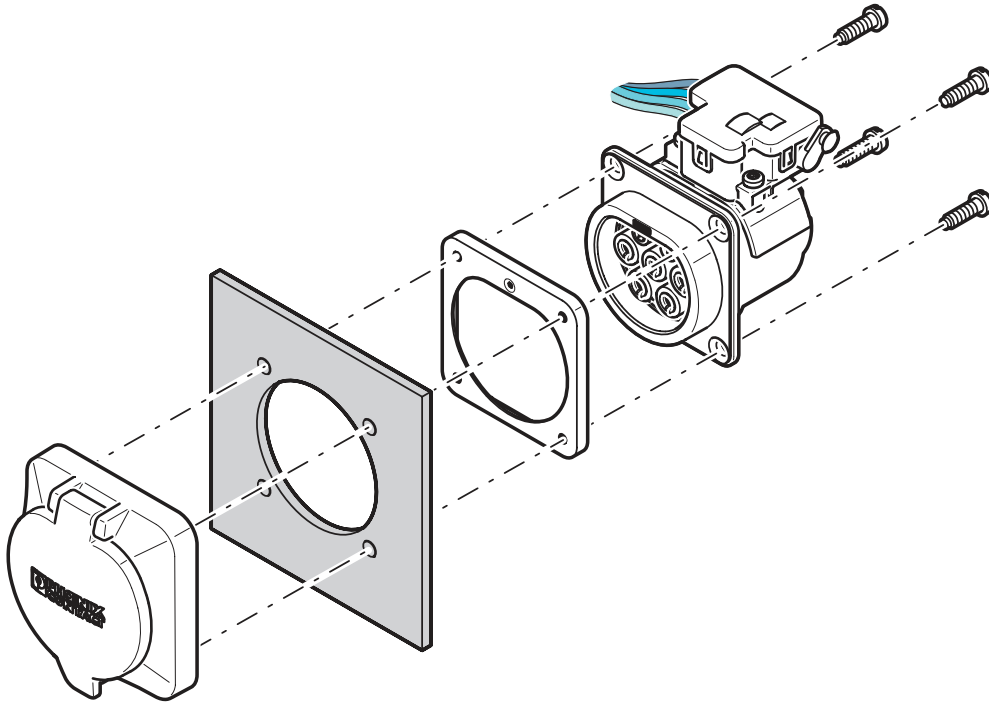

Rear mounting with rear protective cover screw connection

The screw connection for a protective cover from the accessories range (EV-T2SC) only supports rear mounting. The panel thickness must not exceed 5 mm. The sealing frame that is slid on from the rear must contact the housing panel flush with the flat side and must completely surround the infrastructure socket outlet.

EV-T2M3SE24-3AC32A-0,7M6,0E10 - Infrastructure charging socket

1405216

<https://www.phoenixcontact.com/us/products/1405216>

Dimensional drawing

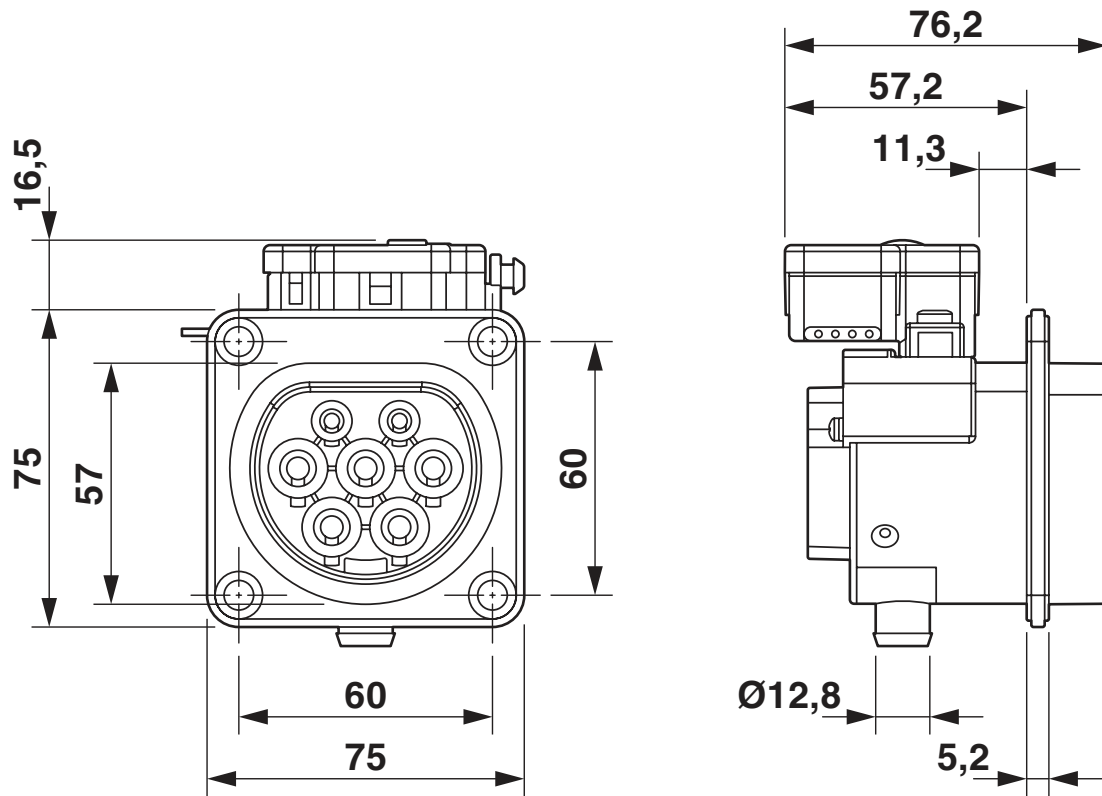

Dimensional drawing

EV-T2M3SE24-3AC32A-0,7M6,0E10 - Infrastructure charging socket



1405216

<https://www.phoenixcontact.com/us/products/1405216>

Schematic diagram

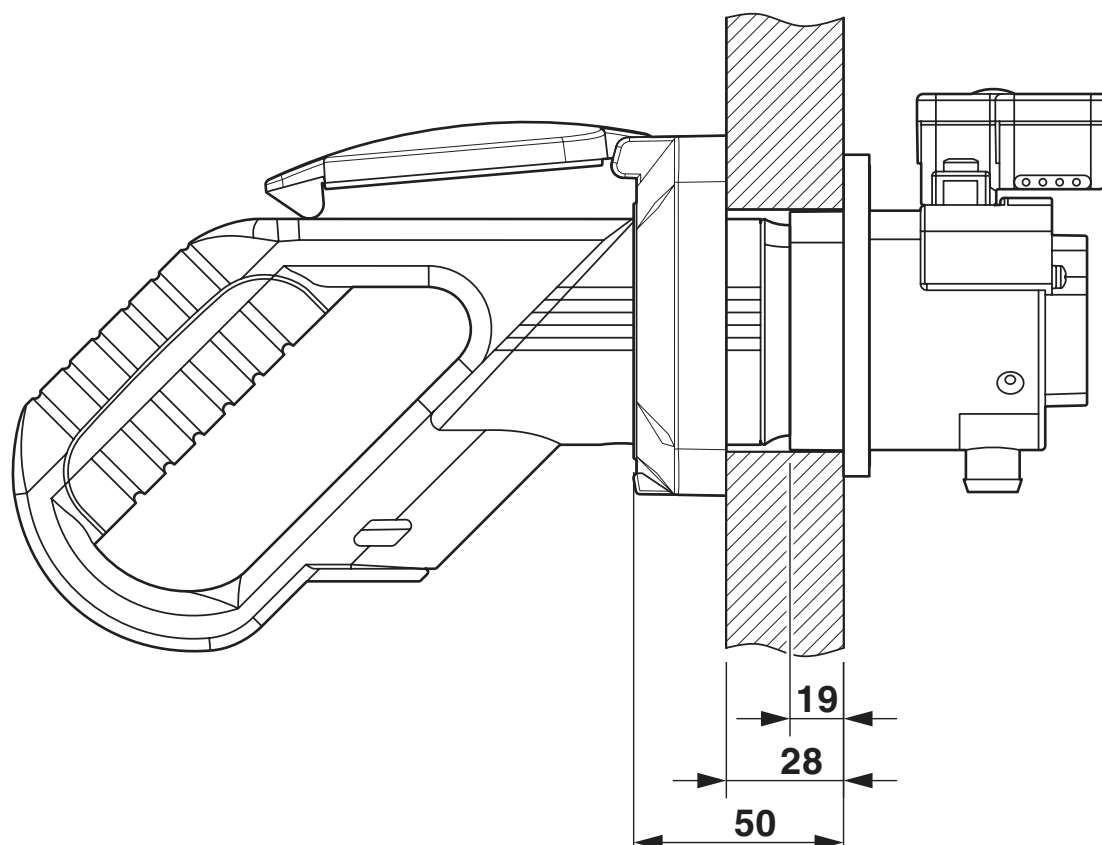

Panel thickness for rear mounting (max. 50 mm, with Phoenix Contact protective cover, max. 22 mm)

EV-T2M3SE24-3AC32A-0,7M6,0E10 - Infrastructure charging socket

1405216

<https://www.phoenixcontact.com/us/products/1405216>

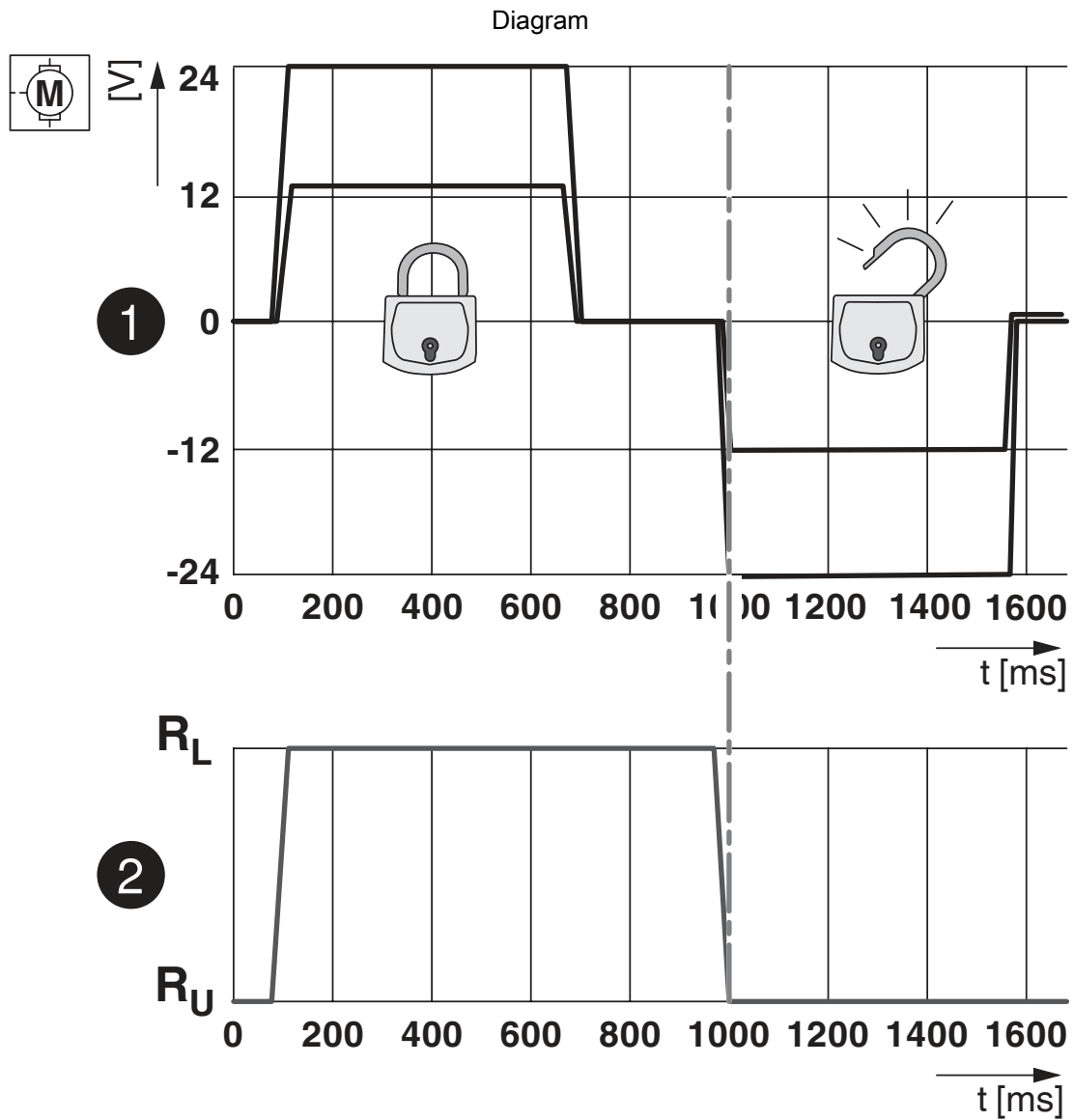

Locking states of the locking actuator

EV-T2M3SE24-3AC32A-0,7M6,0E10 - Infrastructure charging socket

1405216

<https://www.phoenixcontact.com/us/products/1405216>

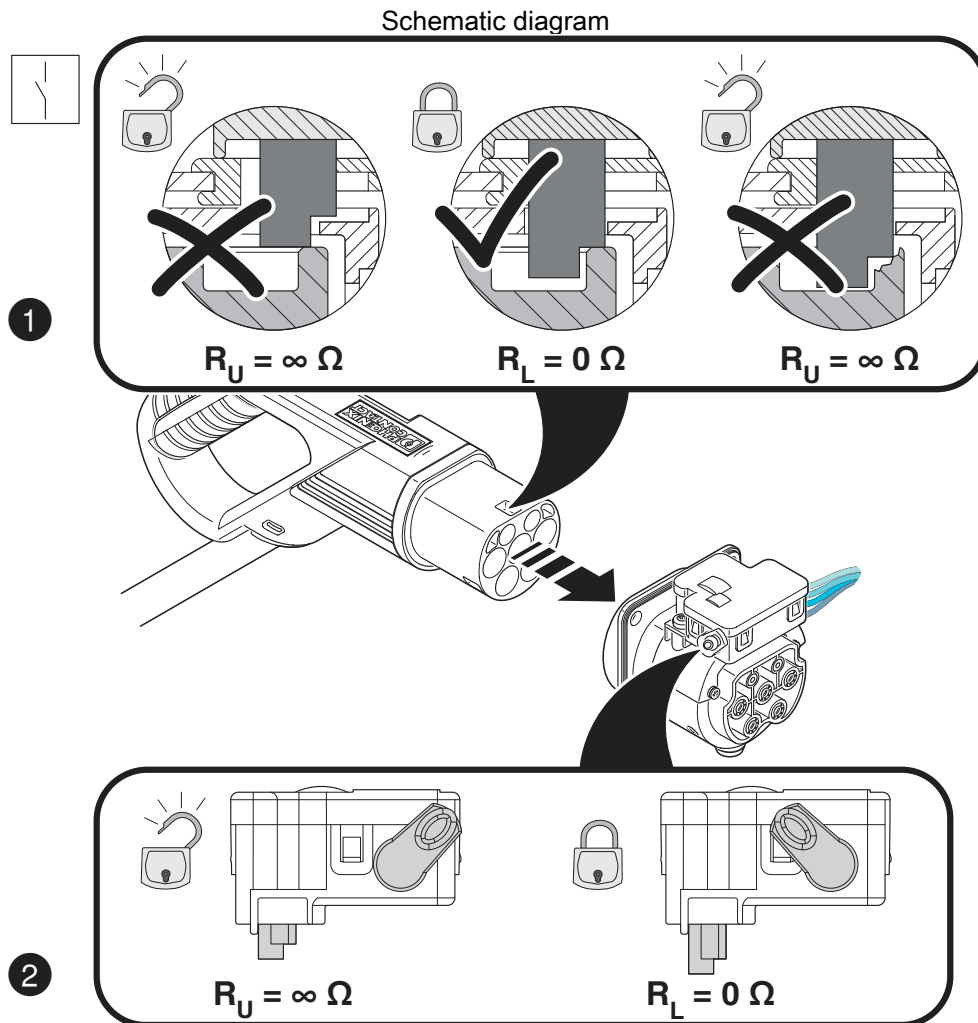

Detection of the Infrastructure Plug

EV-T2M3SE24-3AC32A-0,7M6,0E10 - Infrastructure charging socket

1405216

<https://www.phoenixcontact.com/us/products/1405216>

Connection diagram

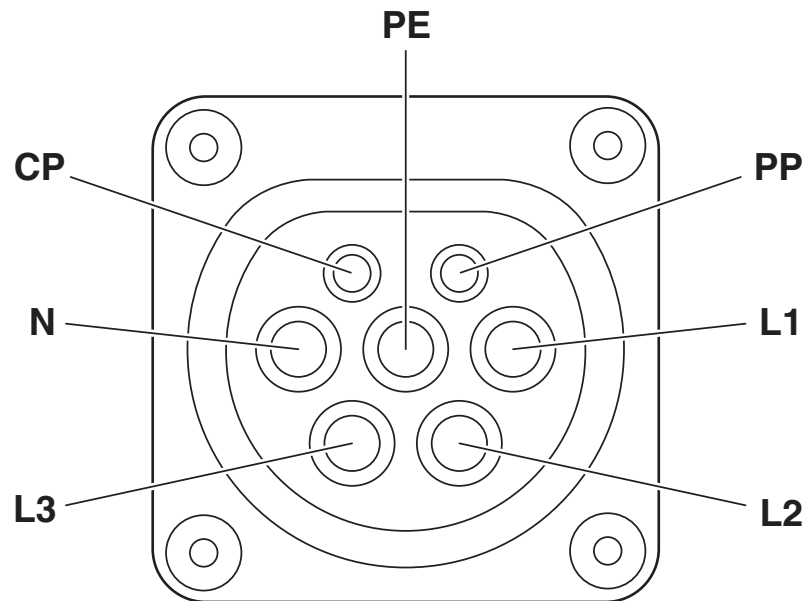

Pin assignment of infrastructure charging socket

EV-T2M3SE24-3AC32A-0,7M6,0E10 - Infrastructure charging socket



1405216

<https://www.phoenixcontact.com/us/products/1405216>

Schematic diagram

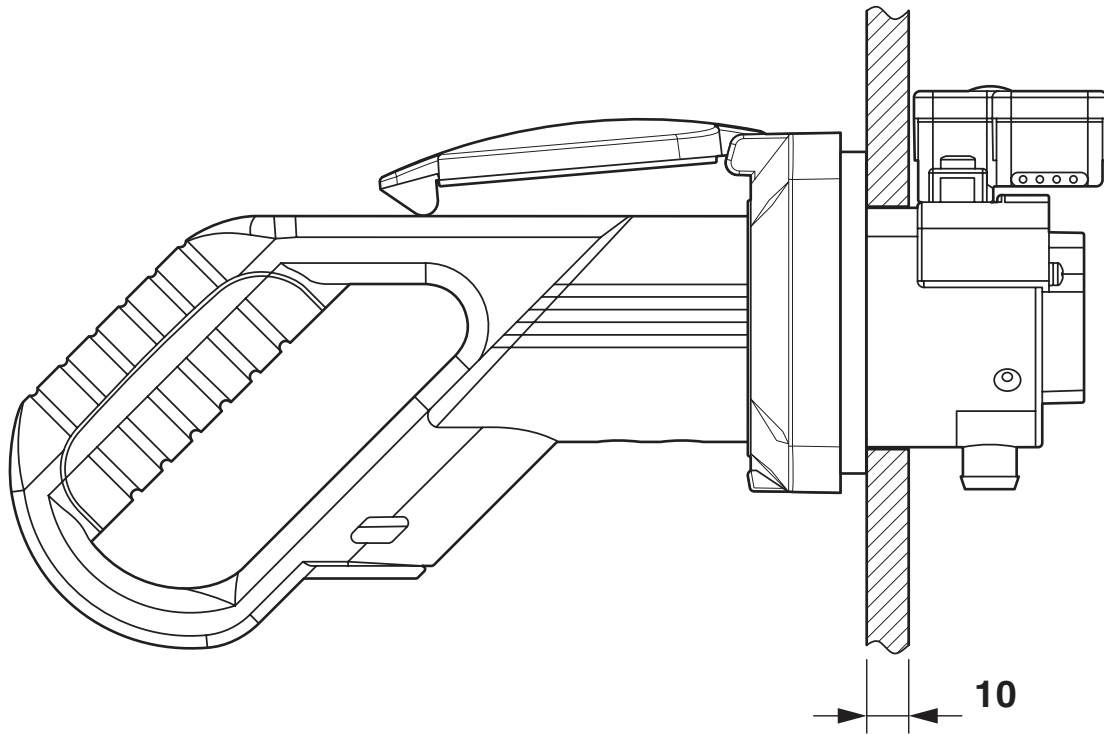

Panel thickness for front mounting (in mm)

EV-T2M3SE24-3AC32A-0,7M6,0E10 - Infrastructure charging socket

1405216

<https://www.phoenixcontact.com/us/products/1405216>

Schematic diagram

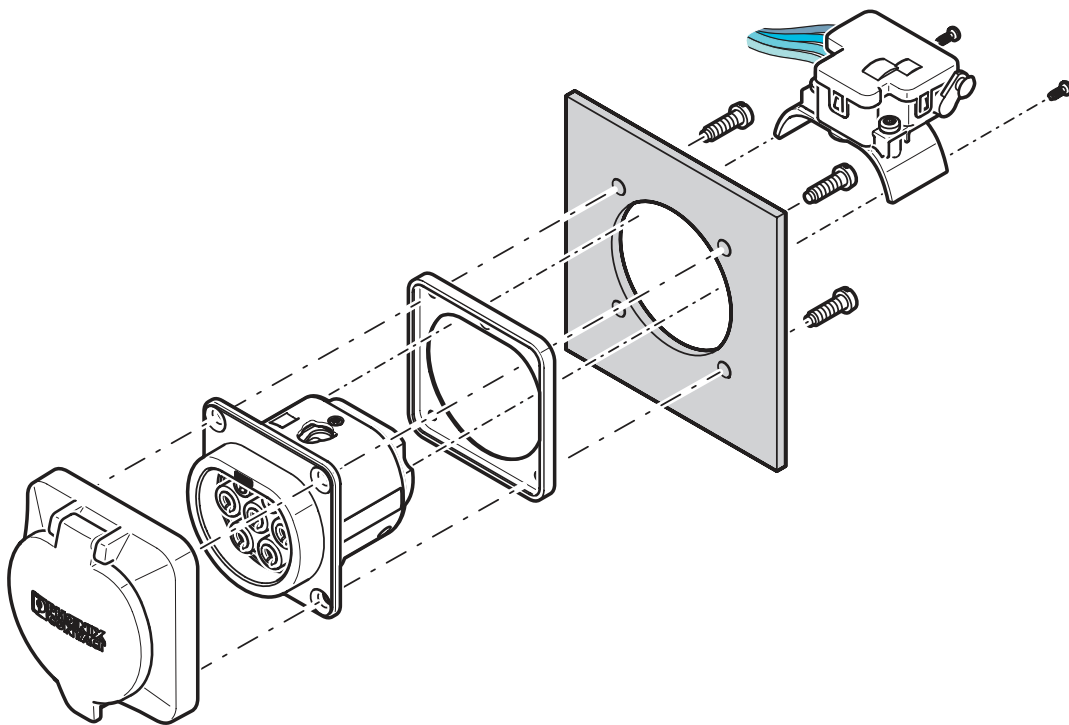

Front mounting with rear protective cover screw connection

Front mounting is only possible when the locking actuator is removed. We recommend using an infrastructure socket outlet without pre-assembled locking actuator (EV-T2M3SE-...E0..., e.g., 1621729).

The screw connection for a protective cover from the accessories range (EV-T2SC) only supports rear mounting. The panel thickness must not exceed 10 mm. The sealing frame that is slid on from the front must contact the housing panel flush with the flat side and must completely surround the infrastructure socket outlet.

EV-T2M3SE24-3AC32A-0,7M6,0E10 - Infrastructure charging socket

1405216

<https://www.phoenixcontact.com/us/products/1405216>

Schematic diagram

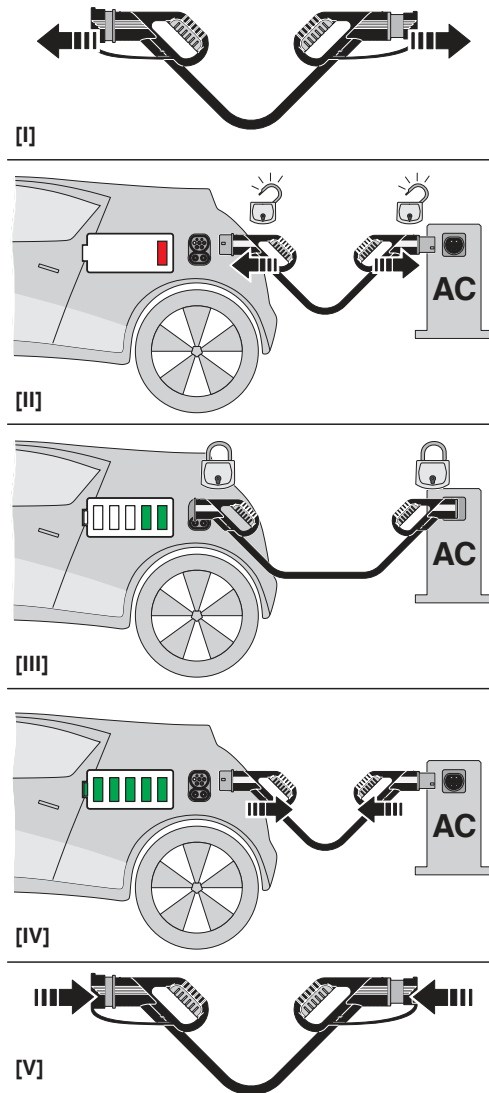

Operating instructions

EV-T2M3SE24-3AC32A-0,7M6,0E10 - Infrastructure charging socket

1405216

<https://www.phoenixcontact.com/us/products/1405216>

Block diagram

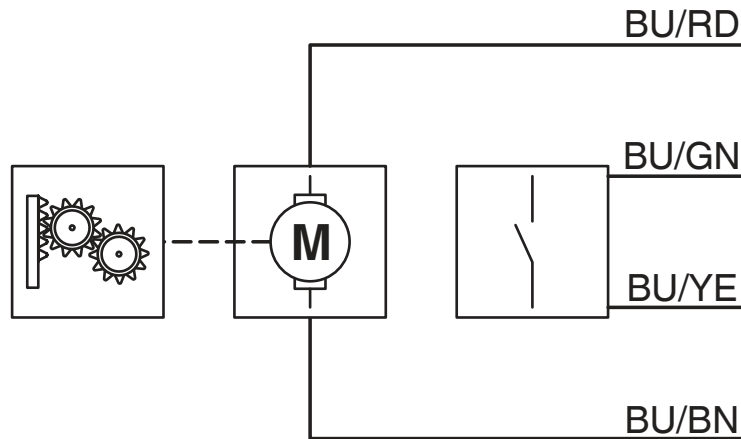

Block diagram of the locking actuator

Dimensional drawing

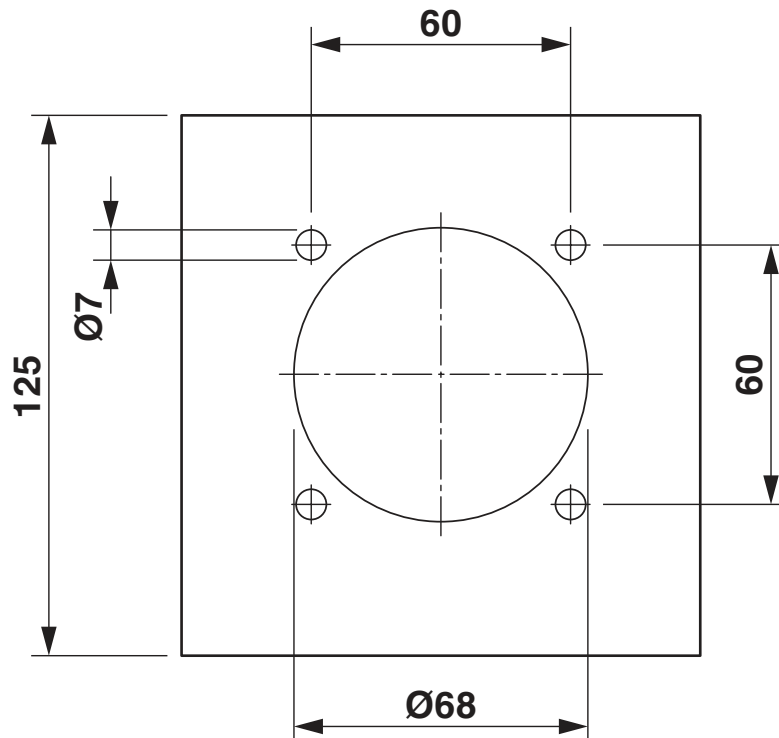

Hole image

EV-T2M3SE24-3AC32A-0,7M6,0E10 - Infrastructure charging socket

1405216

<https://www.phoenixcontact.com/us/products/1405216>

Schematic diagram

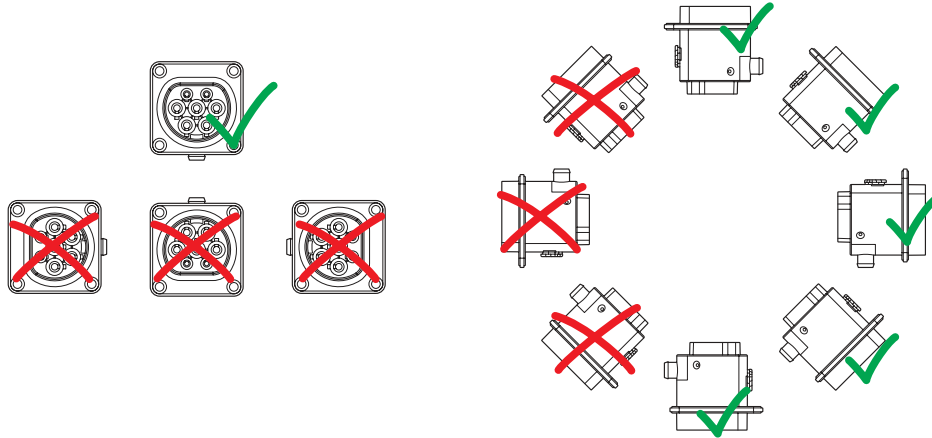

Installation positions

EV-T2M3SE24-3AC32A-0,7M6,0E10 - Infrastructure charging socket



1405216

<https://www.phoenixcontact.com/us/products/1405216>

Classifications

ECLASS

ECLASS-11.0	27144706
-------------	----------

ETIM

ETIM 7.0	EC002898
----------	----------

UNSPSC

UNSPSC 21.0	39121522
-------------	----------

EV-T2M3SE24-3AC32A-0,7M6,0E10 - Infrastructure charging socket



1405216

<https://www.phoenixcontact.com/us/products/1405216>

Environmental product compliance

China RoHS

Environmentally Friendly Use Period = 10;

For information on hazardous substances, refer to the manufacturer's declaration available under "Downloads"

EV-T2M3SE24-3AC32A-0,7M6,0E10 - Infrastructure charging socket



1405216

<https://www.phoenixcontact.com/us/products/1405216>

Accessories

EV-LABEL-C-SO - Label

1315521

<https://www.phoenixcontact.com/us/products/1315521>

CHARX connect, Label, Accessories, for AC type 2 infrastructure charging socket and for AC type 2 infrastructure charging plug, DIN EN 17186



EV-T2SC - Protective cover

1405217

<https://www.phoenixcontact.com/us/products/1405217>



CHARX connect basic, Protective cover, square, Accessories, with self-locking mechanism, for attaching to infrastructure charging sockets, Type 2, IEC 62196-2, Front mounting, M5 thread, housing: black, Embossed PHOENIX CONTACT logo

EV-T2M3SE24-3AC32A-0,7M6,0E10 - Infrastructure charging socket



1405216

<https://www.phoenixcontact.com/us/products/1405216>

EV-T2SF - Panel mounting frames

1405218

<https://www.phoenixcontact.com/us/products/1405218>



CHARX connect basic, Panel mounting frames, Accessories, for attaching to infrastructure charging sockets, Type 2, IEC 62196-2, Front mounting, M5 thread, housing: black, Without logo

EV-GBSCO - Protective cover

1623415

<https://www.phoenixcontact.com/us/products/1623415>



CHARX connect basic, Protective cover, circular, Accessories, with self-opening mechanism, for attaching to infrastructure charging sockets, GB/T, Type 2, GB/T 20234.2, IEC 62196-2, Front mounting, housing: black, Adhered "PHOENIX CONTACT" sticker

EV-T2M3SE24-3AC32A-0,7M6,0E10 - Infrastructure charging socket



1405216

<https://www.phoenixcontact.com/us/products/1405216>

EV-GBSC - Protective cover

1623416

<https://www.phoenixcontact.com/us/products/1623416>



CHARX connect basic, Protective cover, circular, Accessories, with self-locking mechanism, for attaching to infrastructure charging sockets, GB/T, Type 2, GB/T 20234.2, IEC 62196-2, Front mounting, housing: black, Adhered "PHOENIX CONTACT" sticker

EV-GBSC-D6,5MM - Protective cover

1623888

<https://www.phoenixcontact.com/us/products/1623888>



CHARX connect basic, Protective cover, circular, Accessories, with self-locking mechanism, for attaching to infrastructure charging sockets, GB/T, Type 2, GB/T 20234.2, IEC 62196-2, Front mounting, housing: black, Adhered "PHOENIX CONTACT" sticker

EV-T2M3SE24-3AC32A-0,7M6,0E10 - Infrastructure charging socket



1405216

<https://www.phoenixcontact.com/us/products/1405216>

EV-T2M3S-E-LOCK12V - Locking

1624129

<https://www.phoenixcontact.com/us/products/1624129>



CHARX connect modular, Locking, Accessories, for attaching to infrastructure charging sockets, Type 2, GB/T, IEC 61851-1, Single wires, length: 0.5 m, locking actuator: 12 V, 4-pos.

EV-T2M3S-E-LOCK24V - Locking

1622317

<https://www.phoenixcontact.com/us/products/1622317>



CHARX connect modular, Locking, Accessories, with single-core wires, without holder, for locking infrastructure charging sockets when plug is inserted, Type 2, GB/T, IEC 61851-1, Single wires, length: 0.5 m, locking actuator: 24 V, 4-pos.

EV-T2M3SE24-3AC32A-0,7M6,0E10 - Infrastructure charging socket



1405216

<https://www.phoenixcontact.com/us/products/1405216>

EV-T2M3S-DRAINAGE-GASKET - Seal

1621668

<https://www.phoenixcontact.com/us/products/1621668>

CHARX connect basic, Seal, For the discharge nozzle below the infrastructure charging socket if there is no drainage tube present, Type 2, IEC 62196-2



EV-T2M3S-E-LOCK-GASKET - Seal

1621465

<https://www.phoenixcontact.com/us/products/1621465>

CHARX connect basic, Seal, For the mounting surface of the locking actuator above the infrastructure charging socket when there is no locking actuator present, Type 2, IEC 62196-2



EV-T2M3SE24-3AC32A-0,7M6,0E10 - Infrastructure charging socket

1405216

<https://www.phoenixcontact.com/us/products/1405216>

EM-CP-PP-ETH - AC charging controller

2902802

<https://www.phoenixcontact.com/us/products/2902802>



EV charge control is used to charge electrical vehicles on the 3-phase AC mains power supply according to IEC 61851-1 Mode 3. All necessary control functions are integrated. Additional functions are available for various charging applications.

EV-CC-AC1-M3-CBC-SER-HS - AC charging controller

1622452

<https://www.phoenixcontact.com/us/products/1622452>



The EV-CC-AC1-M3-CBC-SER-HS charging controller with housing for DIN rail mounting is used for charging electric vehicles at 3-phase AC networks according to IEC 61851-1, Mode 3. All charging functions, comprehensive configuration settings as well as a locking controller are already integrated.

EV-T2M3SE24-3AC32A-0,7M6,0E10 - Infrastructure charging socket

1405216

<https://www.phoenixcontact.com/us/products/1405216>

EV-CC-AC1-M3-CBC-SER-PCB - AC charging controller

1622453

<https://www.phoenixcontact.com/us/products/1622453>



The EV-CC-AC1-M3-CBC-SER-PCB charging controller as PCB is used for charging electric vehicles at 3-phase AC networks according to IEC 61851-1, Mode 3. All charging functions, comprehensive configuration settings as well as a locking controller are already integrated.

EV-CC-AC1-M3-CBC-SER-PCB-XC-25 - AC charging controller

1627743

<https://www.phoenixcontact.com/us/products/1627743>



The EV-CC-AC1-M3-CBC-SER-PCB charging controller as PCB is used for charging electric vehicles at 3-phase AC networks according to IEC 61851-1, Mode 3. All charging functions, comprehensive configuration settings as well as a locking controller are already integrated.

EV-T2M3SE24-3AC32A-0,7M6,0E10 - Infrastructure charging socket



1405216

<https://www.phoenixcontact.com/us/products/1405216>

EV-CC-AC1-M3-CBC-SER-PCB-MSTB - AC charging controller

1627353

<https://www.phoenixcontact.com/us/products/1627353>



The EV-CC-AC1-M3-CBC-SER-PCB-MSTB charging controller as a PCB for charging electric vehicles according to IEC 61851-1, Mode 3, Case B (Socket Outlet) or C (Vehicle Connector). Connection via PCB connector on header.

Phoenix Contact 2023 © - all rights reserved
<https://www.phoenixcontact.com>

Phoenix Contact USA
586 Fulling Mill Road
Middletown, PA 17057, United States
(+717) 944-1300
info@phoenixcon.com