

**Arm<sup>®</sup> Cortex<sup>®</sup>-M**  
**32-bit Microcontroller**

**NuMicro<sup>®</sup> Family**  
**M261/M262/M263 Series**  
**Product Brief**

*The information described in this document is the exclusive intellectual property of Nuvoton Technology Corporation and shall not be reproduced without permission from Nuvoton.*

*Nuvoton is providing this document only for reference purposes of NuMicro microcontroller based system design. Nuvoton assumes no responsibility for errors or omissions.*

*All data and specifications are subject to change without notice.*

For additional information or questions, please contact: Nuvoton Technology Corporation.

[www.nuvoton.com](http://www.nuvoton.com)

## 1 GENERAL DESCRIPTION

The NuMicro<sup>®</sup> M261/M262/M263 series is a low-power microcontroller platform based on Arm<sup>®</sup> Cortex<sup>®</sup>-M23 core for Armv8-M architecture. It runs up to 64 MHz with 512 Kbytes embedded Flash memory in dual bank mode supporting Over-The-Air (OTA) firmware update and 96 Kbytes embedded SRAM. The 32-bit low-power microcontrollers supports low supply voltage from 1.8 ~ 3.6V and operating temperature range from -40 ~ +105 °C.

### Low-power Technology for IoT application

Low power and robust security are two major vitals for Internet-of-Things (IoT) applications. The NuMicro<sup>®</sup> M261/M262/M263 series provides multi power modes for diverse operating scenarios, such as Power-down mode (PD), Fast Wake-up Power-down mode (FWPD), Low Leakage Power-down mode (LLPD), Ultra Low Leakage Power-down mode (ULLPD), Standby Power-down mode (SPD) and Deep Power-down mode (DPD). The NuMicro<sup>®</sup> M261/M262/M263 series also integrates RTC with independent V<sub>BAT</sub> voltage source pin to support low power mode with main power off and V<sub>BAT</sub> only. Regarding the power consumption of the NuMicro<sup>®</sup> M261/M262/M263 series, 97 µA/MHz (LDO mode) and 45 µA/MHz (DC-DC mode) in normal run mode, 2.8 µA in Standby Power-down mode, and less than 2µA in Deep Power-down mode. It's low power, wide supply voltage and fast wake-up features make it suitable for battery-powered IoT applications.

### Secure Boot - Make sure your products in secure execution

The NuMicro<sup>®</sup> M261/M262/M263 series provides secure boot function for a system developer to create a secure execution system in the microcontroller. The secure boot is a chain of secure process for verifying each software identity and integrity on the system. Secure boot can help to make sure that a device boots using only software that is trusted by the original developer. When the MCU starts, the firmware checks the signature of boot software, if the signatures are valid, the MCU boots, and the firmware gives control to the operating system. Otherwise, the system will not run at all.

### eXecute-Only-Memory (XOM) - Protect the intelligent property of developers

The NuMicro<sup>®</sup> M261/M262/M263 series provides 4-region programmable eXecute-Only-Memory (XOM) to secure critical program codes. The AES 256/192/128 hardware accelerator and True Random Number Generator (TRNG) are built-in for data encryption. Up to six tamper detection pins are implemented to avoid malicious damage from hacker. Accompany with 96-bit Unique Identification (UID) and 128-bit Unique Customer Identification (UCID) to enhance the product security.

### Voltage Adjustable Interface (VAI) - Support 2<sup>nd</sup> I/O voltage without level-shifter

The NuMicro<sup>®</sup> M261/M262/M263 series integrates Voltage Adjustable Interface (VAI), up to 6 I/O pins to support the 2<sup>nd</sup> I/O voltage from 1.8 ~ 3.6V to save level shifter components while connecting to external devices.

### Secure Digital Host Controller (SDHC)

The NuMicro<sup>®</sup> M261/M262/M263 series integrates one set of Secure Digital Host Controllers (SDHC), compliant with SD Memory Card Specification Version 2.0. It supports 50 MHz to achieve 200 Mbps at 3.3V operation, and dedicated DMA master with Scatter-Gather function to accelerate the data transfer between system memory and SD/SDHC/SDIO card.

### Rich Pheripherals for comprehensive product application scenarios

The NuMicro<sup>®</sup> M261/M262/M263 series is equipped with plenty of peripherals such as Timers, Watchdog Timers, RTC, PDMA, External Bus Interface (EBI), Low-power UART, Universal Serial Control Interface (USCI), Qual SPI (QSPI), SPI/I<sup>2</sup>S, I<sup>2</sup>C, Smart Card Interface (ISO-7816-3), GPIOs, up to 24 channels of PWM, makes it highly suitable for connecting comprehensive external modules and LED lighting control. The NuMicro<sup>®</sup> M261/M262/M263 series also integrates high performance analog front-end circuit blocks, such as one 16 channels of 12-bit 3.76 MSPS SAR ADC, two 12-bit 1 MSPS voltage type DAC, two rail-to-rail analog comparator

(ACMP), temperature sensor, low voltage reset (LVR) and brown-out detector (BOD) to enhance product performance, reduce external components and form factor simultaneously.

**USB 2.0 Full Speed On-The-Go (OTG) supporting Crystal-less function**

The part numbers of NuMicro® M262/M263 series are all based on NuMicro® M261 series, it integrates USB 2.0 Full Speed On-The-Go (OTG) transceiver, compliant with USB OTG Supplement 2.0, can configurable as host-only, device only or ID-dependent. It also integrates USB 1.1 Host Controller and USB 2.0 Full Speed Device Controller. The NuMicro® M262/M263 series supports crystal-less function that can generate precise frequency required by USB protocol without the need of external crystal, to reduce both the BOM cost and PCB size.

**Controller Area Network (CAN)**

The part numbers of NuMicro® M263 series are all based on NuMicro® M261 series, it supports one set of CAN 2.0B controllers, the bit rate can be programmed to values up to 1MBit/s. This CAN bus can be set to be one of six paired I/Os by PinConfigure.

**Available Packages**

The NuMicro® M261/M262/M263 series provides 9 product part numbers. The package types of NuMicro® M261/M262/M263 series includes QFN33 (5mm x 5mm) · LQFP64 (7mm x 7mm) and LQFP128 (14mm x 14mm). Pin-to-pin compatible in same package makes optimizing product features and performance easily

**Hardware/Software Developing Environment**

Nuvoton NuMaker M261/M262/M263 evaluation boards (NK-M263KI) and Nu-Link debugger are available for evaluation and product development. 3rd Party IDEs such as Keil MDK, IAR EWARM and NuEclipse IDE with GNU GCC compilers, are also supported.

**1.1 M261/M262/M263 Series Key Features**

Product Line	Connectivity											Timer	PWM	PDMA	EBI	Analog Comp.	ADC (12-bit)	DAC (12-bit)	Crypto	Tamper	RTC (V <sub>BAT</sub> )
	LPUART	ISO-7816-3	QSPI	SPI/ I <sup>2</sup> S	I <sup>2</sup> C	I <sup>2</sup> S	USCI	SDHC	LIN	CAN	USB OTG										
M261/ M262/ M263	6	3	1	4	3	1	2	1	2	1	1	4	24	16	V	2	16	2	V	6	V

Table 1-1 NuMicro® M261/M262/M263 Series Key Features Support Table

The NuMicro® M261/M262/M263 series is suitable for a wide range of applications such as:

- Smart Home / Smart Home Appliance / Smart Door lock
- Industrial Control / Industrial Automation
- Smart City Facilities / Security Alarm System
- IoT Device / Wireless Sensor Node Device / Communication Modules
- Electronic Payments
- Portable Wireless Data Collector
- Handheld Medical Device

## 2 FEATURES

### ● Operating Characteristics

- Voltage range: 1.8V ~ 3.6V
- Temperature range: -40°C ~ +105°C

### ● Core

- Arm® Cortex®-M23 processor, Armv8-M, runs up to 64 MHz
- 32-bit hardware multiplier/divider

### ● Memories

- Dual bank 512KB Flash for OTA upgrade
- 96KB SRAM
- 4KB LDRAM
- 4KB Key Protection ROM (KPROM)
- 4-region eXecute-Only-Memory (XOM)
- Supports Secure Boot

### ● Clocks

- 4 ~ 24 MHz external high speed crystal oscillator (HXT) for precise timing operation
- 32.768 kHz external low speed crystal oscillator (LXT) for RTC function and low-power system operation
- 12 MHz internal high speed RC oscillator (HIRC) for system operation (After auto-trim ± 0.25%)
- 48 MHz internal high speed RC oscillator (HIRC48) for system operation (After auto-trim ±0.25%)
- 10 kHz internal low speed RC oscillator (LIRC) for Watchdog Timer and wake-up operation
- 32 kHz internal low speed RC oscillator (LIRC32) for RTC function

### ● Power management

- Dual voltage regulator is available for DC-DC converter or LDO
- Supports 1.2V and 0.9V core voltage
- Supports Power-down mode, Standby Power-down mode, Low Leakage Power-down mode, Ultra Low Leakage Power-down mode, Fast Wake-up Power-down mode, and Deep Power-down mode
- Supports external power pin V<sub>BAT</sub> (Standalone V<sub>BAT</sub> for RTC power domain)

### ● Low Power Consumption

- 97 µA/MHz (LDO) and 45 µA/MHz (DC-DC) in operating mode
- 2.8 µA in Standby Power-down mode
- Less than 2 µA in Deep Power-down mode

### ● RTC

- 80 bytes of battery-powered backup registers, which can be cleared by tamper pins
- Supports 6 static and dynamic tamper pins

### ● Timers

- Up to four 32-bit timers

### ● PDMA

- Up to 16 channels

### ● PWM

- Up to 24-channels PWM
- Supports trigger ADC or DAC

- Supports independent mode for PWM output / Capture input channel
- Supports complementary mode for 3 complementary paired PWM output channel

### ● Analog

- Up to 16 channels 12-bit 3.76 MSPS ADC
- Up to 2 sets of rail-to-rail comparators (ACMP)
- Up to 2 sets of 12-bit 1 MSPS voltage type DAC
- Supports external VREF pin or internal reference voltage VREF: 1.6V, 2.0V, 2.5V, and 3.0V

### ● Communication interfaces

- Up to 6 sets of LPUART interface
- Up to 3 sets of I<sup>2</sup>C interface
- Up to 1 set of QSPI interface
- Up to 4 sets of SPI/I<sup>2</sup>S interface (Configured as SPI or I<sup>2</sup>S)
- Up to 3 sets of Smart Card Interface (ISO-7816-3, ISO-7816-3 supports full duplex UART mode)
- Up to 2 sets of USCI (Configured as UART, SPI or I<sup>2</sup>C)
- Up to 1 set of Secure Digital Host Controllers (SDHC), compliant with SD Memory Card Specification Version 2.0
- 16/8-bits EBI (External Bus Interface) interface

### ● VAI (Voltage Adjustable Interface)

- Up to 6 I/O pins to support the 2<sup>nd</sup> I/O voltage from 1.8 ~ 3.6V, applied voltage to the V<sub>DDIO</sub> pin

### ● USB 2.0 Full Speed OTG (Crystal-less)

- USB 2.0 Full Speed OTG (On-The-Go)
- USB 1.1 Host Controller
- USB 2.0 Full Speed Device Controller

### ● CAN (Controller Area Network)

- Supports 1 set of CAN 2.0B controller
- Supports power-down wake-up function

### ● Utility Support

- Arm® Keil MDK and IAR EWARM IDE support for debugging
- Free GNU compiler with NuEclipse IDE support
- ICP (In Circuit Programmer) support for updating internal code via Nu-Link debugger
- PinView for real time monitor the status of all IO pins
- PinConfigure tool for pin assignment, initial code generation and OrCAD/Protel part generation
- ClockConfigure tool for generating the initial source code of system clock

### ● 96-bit Unique ID (UID)

### ● 128-bit Unique Customer ID (UCID)

### ● Packages

- QFN33 (5mm x 5mm), LQFP64 (7mm x 7mm), LQFP128 (14mm x 14mm)

3 BLOCK DIAGRAM

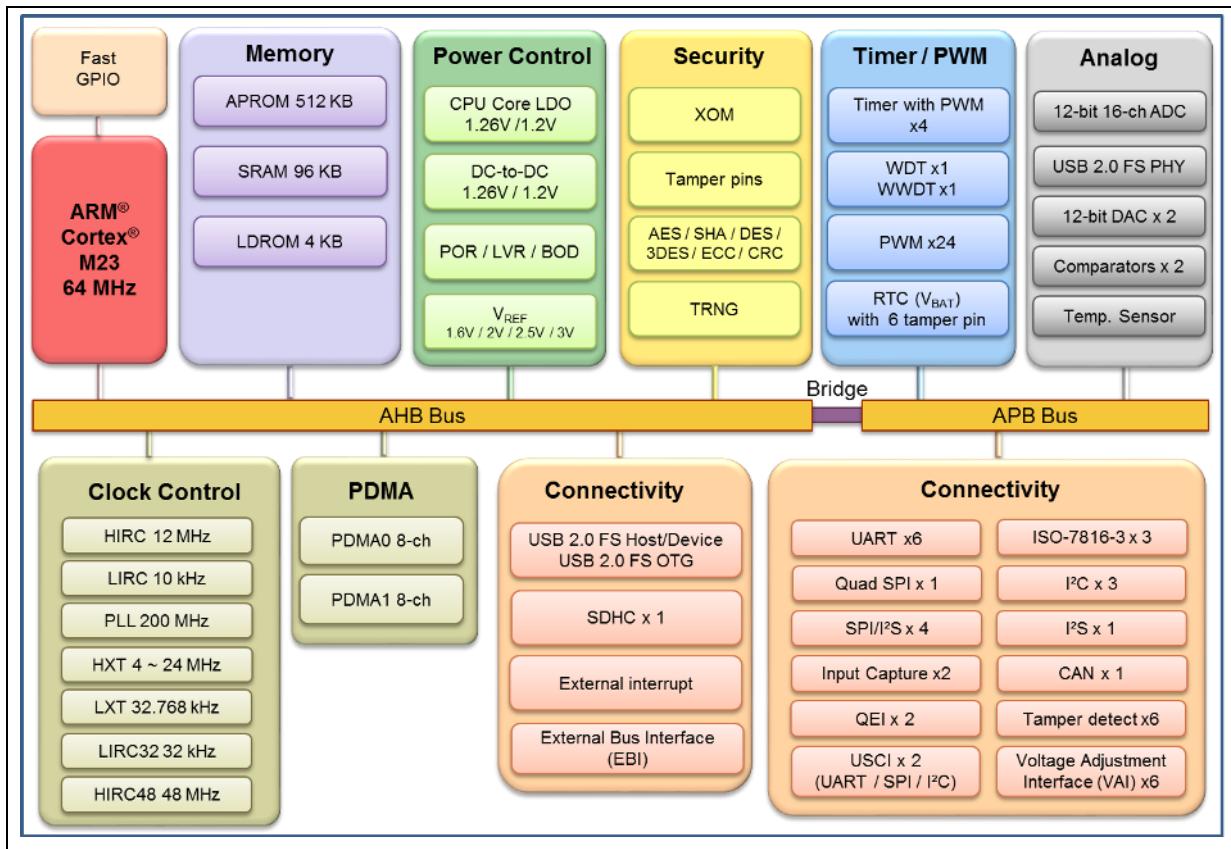

Figure 3-1 NuMicro® M261/M262/M263 Block Diagram

**4 PARTS INFORMATION**

**4.1 M261/M262/M263 Series Naming Rule**

<b>M2</b>	<b>61</b>	<b>Z</b>	<b>I</b>	<b>A</b>	<b>A</b>	<b>E</b>
<b>Core</b>	<b>Line</b>	<b>Package</b>	<b>Flash</b>	<b>SRAM</b>	<b>Reserve</b>	<b>Temperature</b>
Cortex®-M23	61: Control 62: USB 63: USB/CAN	Z: QFN33 (5x5 mm) S: LQFP64 (7x7 mm) K: LQFP128 (14x14 mm)	I: 512 KB	A: 96 KB		E: -40°C ~ +105°C

4.2 M261/M262/M263 Series Selection Guide

4.2.1 M261 Control Series

PART NUMBER	M261			
	ZIAAE	SIAAE	KIAAE	
Flash (KB)	512			
SRAM (KB)	96			
ISP Loader ROM (KB)	4			
I/O	25	51	107	
32-bit Timer	4			
Tamper	-	1	6	
RTC	V			
Connectivity	LPUART	6		
	ISO-7816-3	3*		
	Quad SPI	1		
	SPI/I <sup>2</sup> S	3	4	4
	I <sup>2</sup> S	1		
	I <sup>2</sup> C	3		
	USCI**	2		
	LIN	2		
	CAN	-		
	SDHC	1		
16-bit EPWM	12			
16-bit BPWM	12			
QEI	1	2	2	
ECAP	-	1	2	
USB 2.0 FS OTG	-			
12-bit ADC	9	16	16	
12-bit DAC	2			
Analog Comparator	2			
Cryptography	V			
External Bus Interface	-	V	V	
Package	QFN 33	LQFP 64	LQFP 128	

Note: \* ISO-7816-3 supports full duplex UART mode

\*\* USCI can be configured as UART, SPI or I<sup>2</sup>C

4.2.2 M262 USB Series

PART NUMBER	M262			
	ZIAAE	SIAAE	KIAAE	
Flash (KB)	512			
SRAM (KB)	96			
ISP Loader ROM (KB)	4			
I/O	25	51	107	
32-bit Timer	4			
Tamper	-	1	6	
RTC	V			
Connectivity	LPUART	6		
	ISO-7816-3	3*		
	Quad SPI	1		
	SPI/I <sup>2</sup> S	3	4	4
	I <sup>2</sup> S	1		
	I <sup>2</sup> C	3		
	USCI**	2		
	LIN	2		
	CAN	-		
	SDHC	1		
16-bit EPWM	12			
16-bit BPWM	12			
QEI	1	2	2	
ECAP	-	1	2	
USB 2.0 FS OTG	V			
12-bit ADC	9	16	16	
12-bit DAC	2			
Analog Comparator	2			
Cryptography	V			
External Bus Interface	-	V	V	
Package	QFN 33	LQFP 64	LQFP 128	

Note: \* ISO-7816-3 supports full duplex UART mode

\*\* USCI can be configured as UART, SPI or I<sup>2</sup>C



4.2.3 M263 USB/CAN Series

PART NUMBER	M263			
	ZIAAE	SIAAE	KIAAE	
Flash (KB)	512			
SRAM (KB)	96			
ISP Loader ROM (KB)	4			
I/O	25	51	107	
32-bit Timer	4			
Tamper	-	1	6	
RTC	V			
Connectivity	LPUART	6		
	ISO-7816-3	3*		
	Quad SPI	1		
	SPI/I <sup>2</sup> S	3	4	4
	I <sup>2</sup> S	1		
	I <sup>2</sup> C	3		
	USCI**	2		
	LIN	2		
	CAN	1		
	SDHC	1		
16-bit EPWM	12			
16-bit BPWM	12			
QEI	1	2	2	
ECAP	-	1	2	
USB 2.0 FS OTG	V			
12-bit ADC	9	16	16	
12-bit DAC	2			
Analog Comparator	2			
Cryptography	V			
External Bus Interface	-	V	V	
Package	QFN 33	LQFP 64	LQFP 128	

Note: \* ISO-7816-3 supports full duplex UART mode

\*\* USCI can be configured as UART, SPI or I<sup>2</sup>C

5 PIN CONFIGURATION

5.1 M261 Series Pin Diagram

5.1.1 M261 Series QFN 33-Pin Diagram

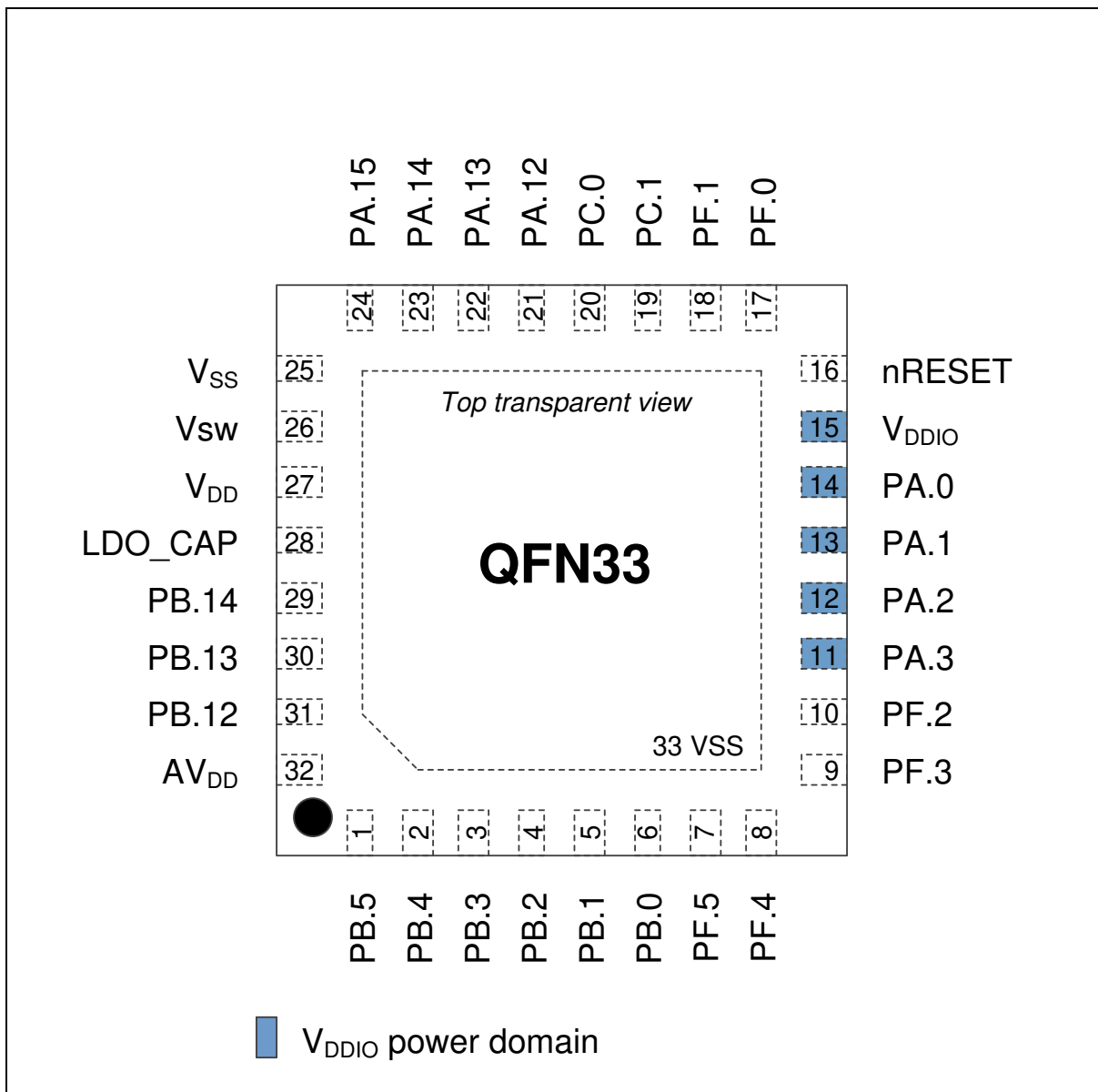

Figure 5-1 M261 Series QFN 33-pin Diagram

5.1.2 M261 Series LQFP 64-Pin Diagram

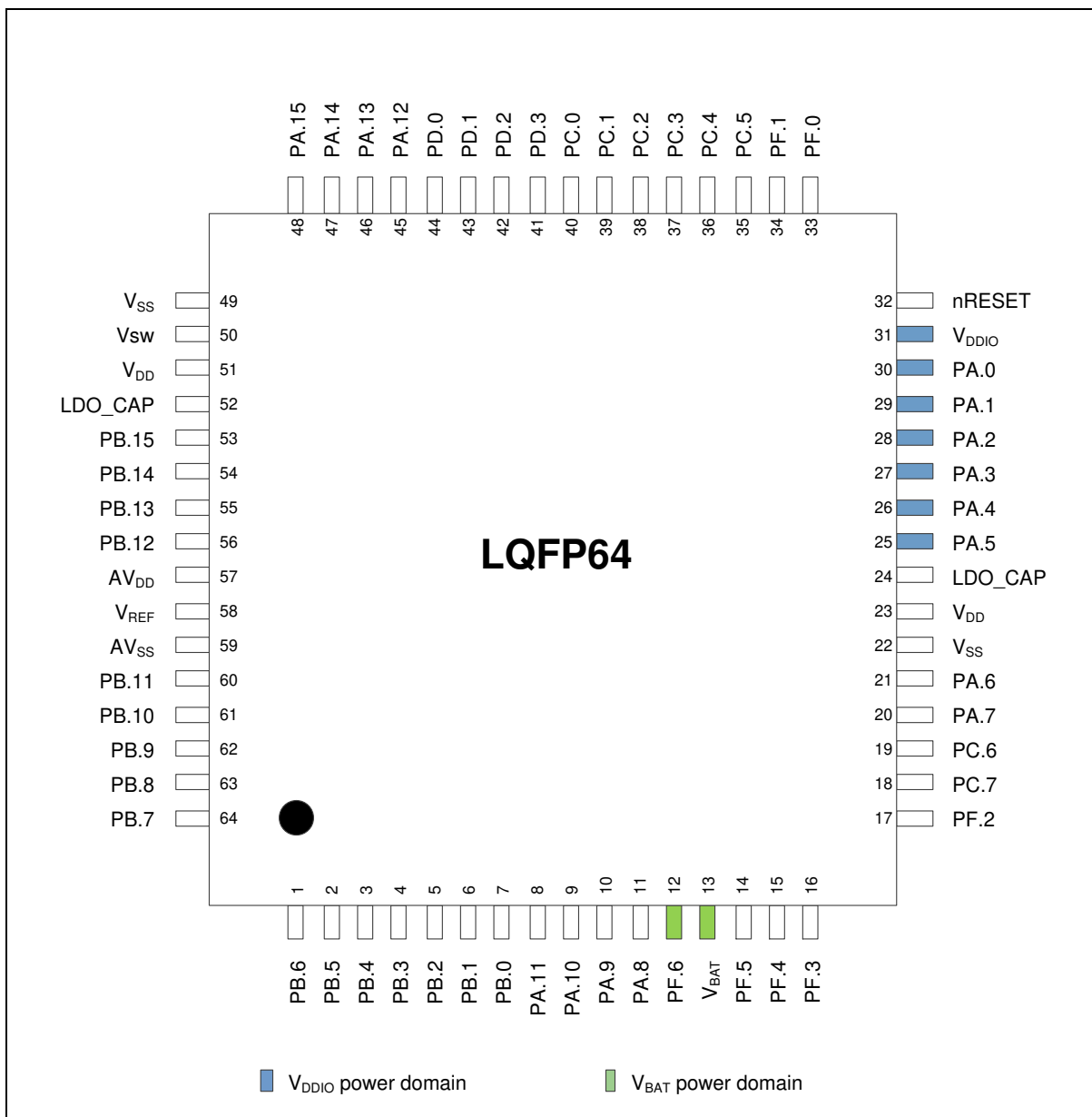

Figure 5-2 NuMicro® M261 Series LQFP 64-pin Diagram

5.1.3 M261 Series LQFP 128-Pin Diagram

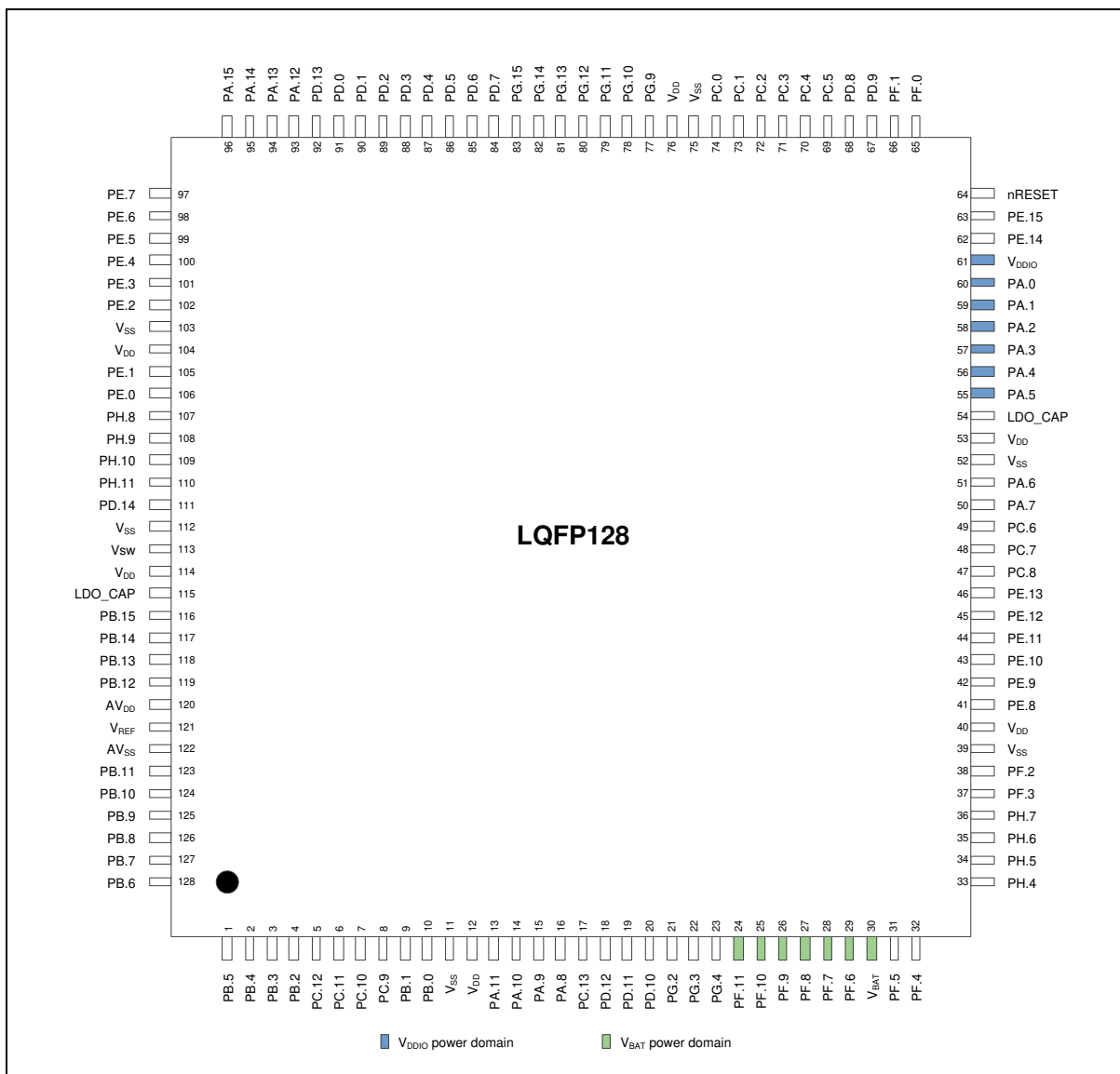

Figure 5-3 NuMicro® M261 Series LQFP 128-pin Diagram

5.2 M262 Series Pin Diagram

5.2.1 M262 Series QFN 33-Pin Diagram

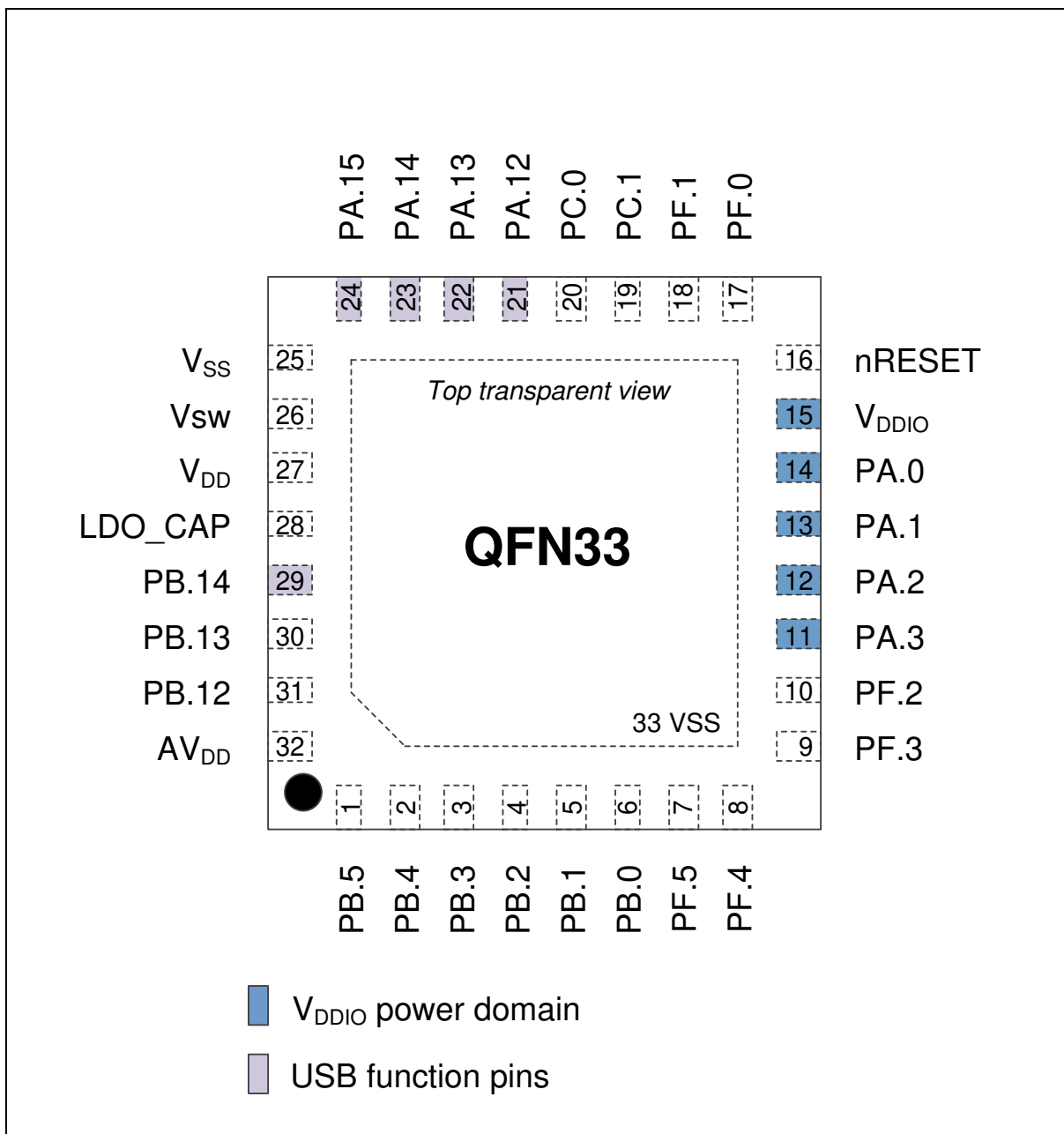

Figure 5-4 NuMicro® M262 Series QFN 33-pin Diagram

5.2.2 M262 Series LQFP 64-Pin Diagram

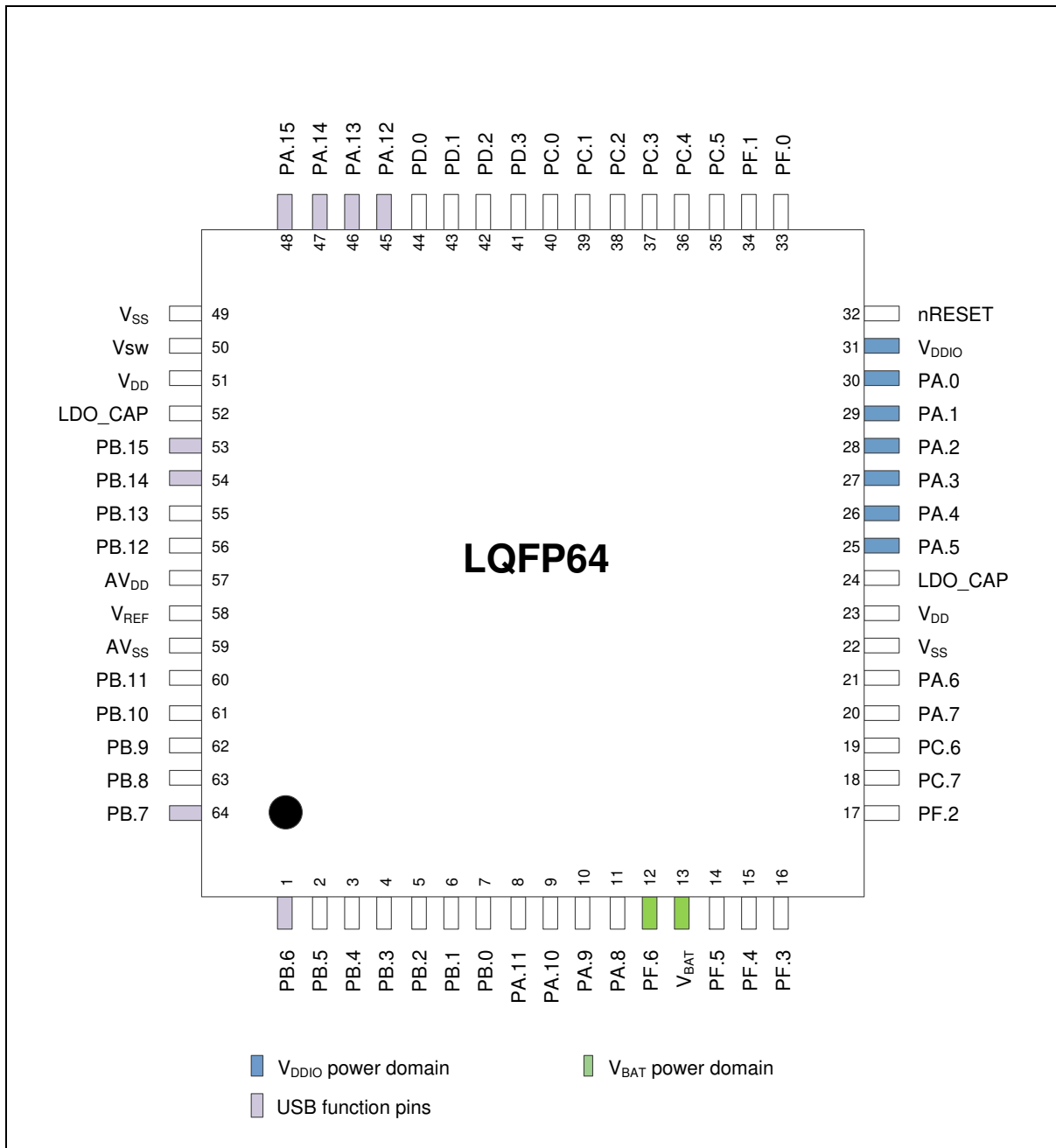

Figure 5-5 NuMicro® M262 Series LQFP 64-pin Diagram

5.2.3 M262 Series LQFP 128-Pin Diagram

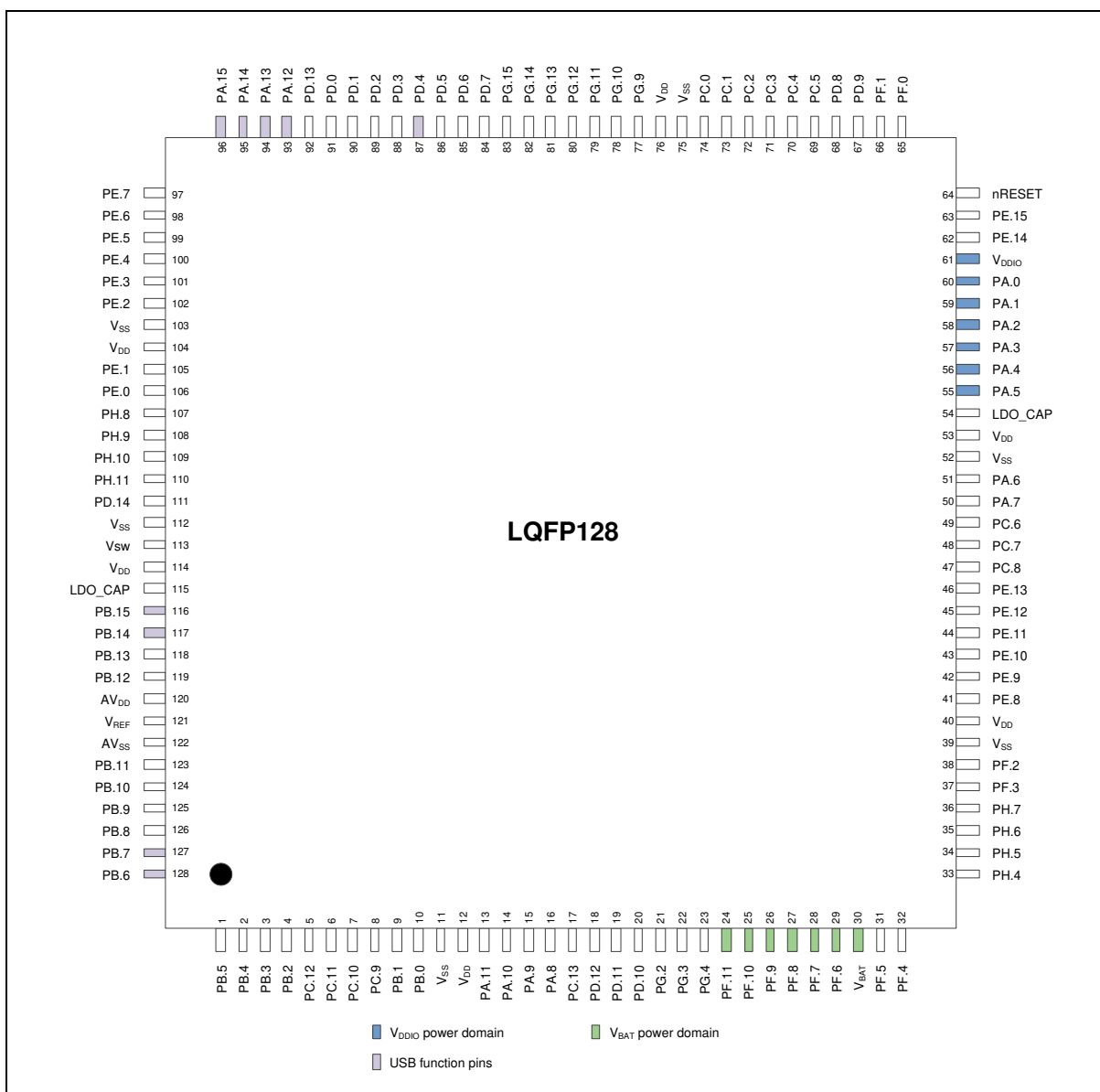

Figure 5-6 NuMicro® M262 Series LQFP 128-pin Diagram

5.3 M263 Series Pin Diagram

5.3.1 M263 Series QFN 33-Pin Diagram

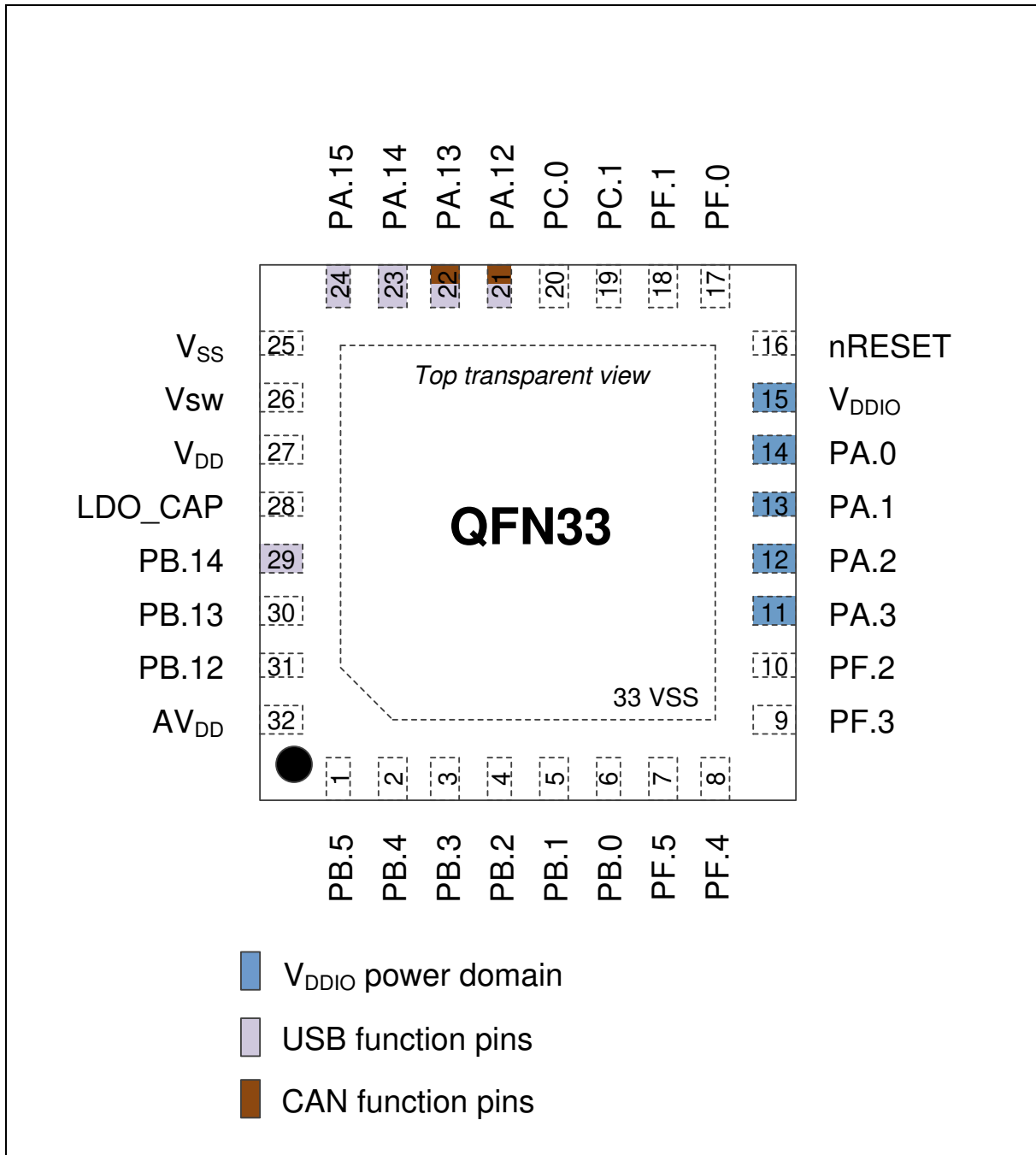

Figure 5-7 NuMicro® M263 Series QFN 33-pin Diagram



5.3.2 M263 Series LQFP 64-Pin Diagram

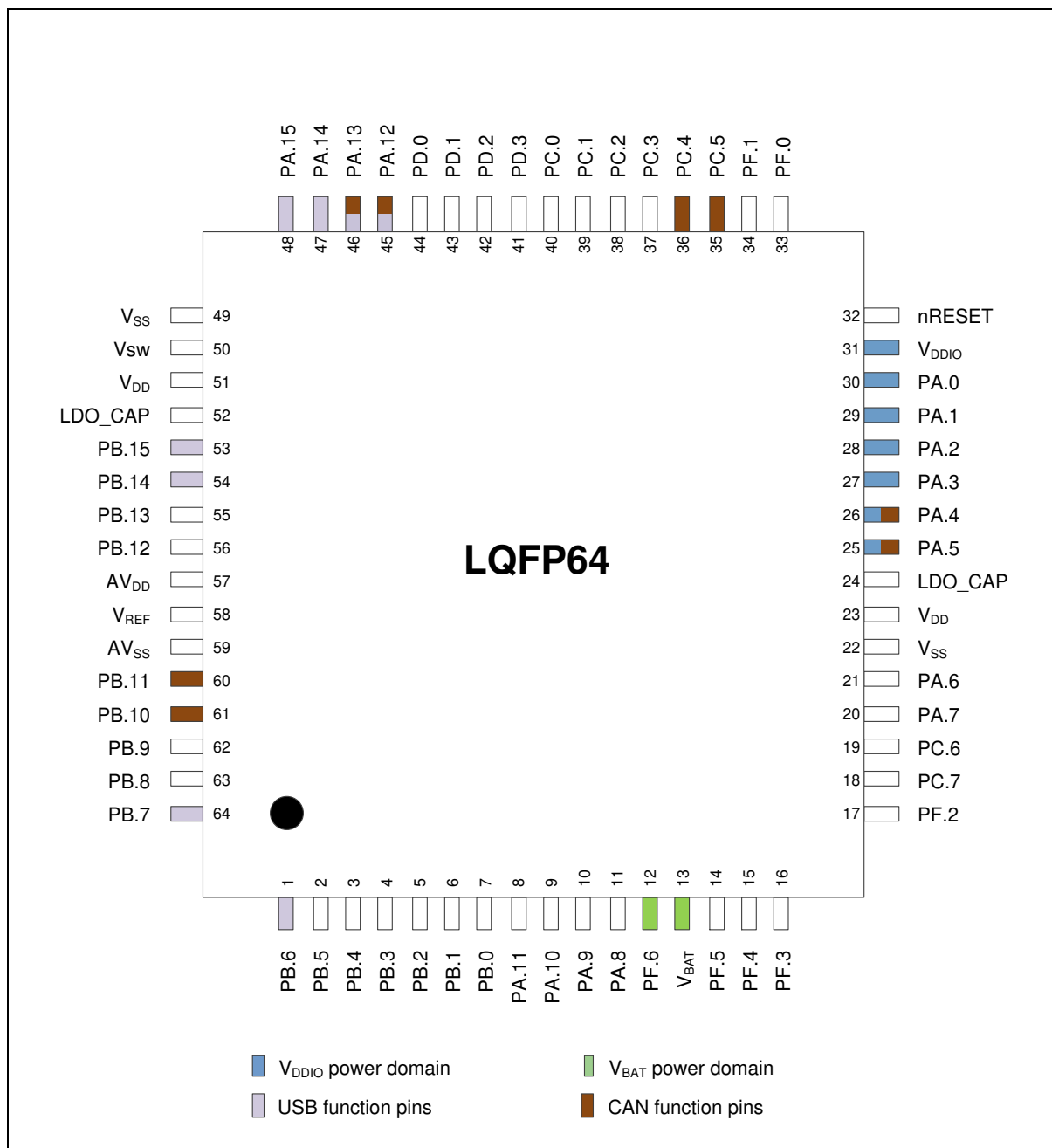

Figure 5-8 NuMicro® M263 Series LQFP 64-pin Diagram

5.3.3 M263 Series LQFP 128-Pin Diagram

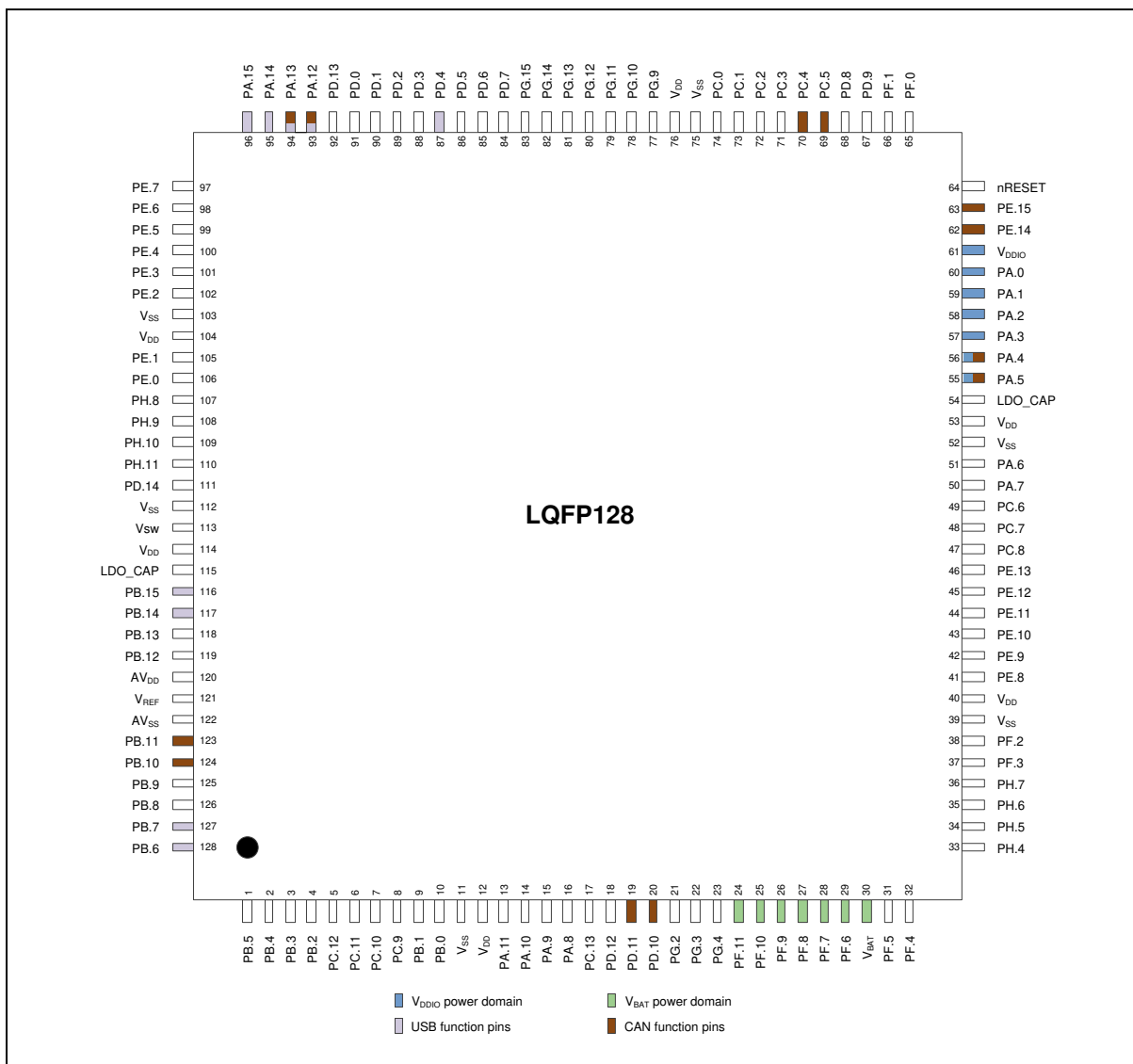

Figure 5-9 NuMicro® M263 Series LQFP 128-pin Diagram

## 6 UTILITIES

### 6.1 Programmer and Debugger

Nu-Link	Basic full speed USB2.0 hardware debugger/programmer
Nu-Link-Pro	Advance hardware debugger/programmer with programming counter
Nu-Link 2.0	Advance high speed USB2.0 hardware debugger/programmer with multi-functions
Nu-Link-Gang	Off-line hardware programmer supports up to four chips programming for mass-production
ISP	In system programming, a software programming tool support UART/USB
ICP	In Chip Programming, a software programming tool support Nu-Link programmer

### 6.2 Development Environment

Programming IDE	Keil MDK, IAR, NuEclipse(GCC)
Software Package	Board Support Package(BSP), Sample Code,
Development IDE	NuTool PinView, NuTool PinConfig, NuTool ClockConfig, NuConsole
RTOS	Mbed, FreeRTOS, Amazon FreeRTOS, Ali-OS
HMI	Support emWin with font create tool and easy GUI builder
Programming IDE	Keil MDK, IAR, NuEclipse(GCC)

### 6.3 Development Board

EVB NuMaker	Part Number	Feature
NK-M263K1	M261ZIAAE, M261SIAAE, M261KIAAE, M262ZIAAE, M262SIAAE, M262KIAAE, M263ZIAAE, M263SIAAE, M263KIAAE,	Support Expand Connector, Arduino Uno Interface

7 PACKAGE DIMENSIONS

7.1 QFN 33-pin (5X5x0.8 mm<sup>3</sup>, Pitch: 0.50 mm)

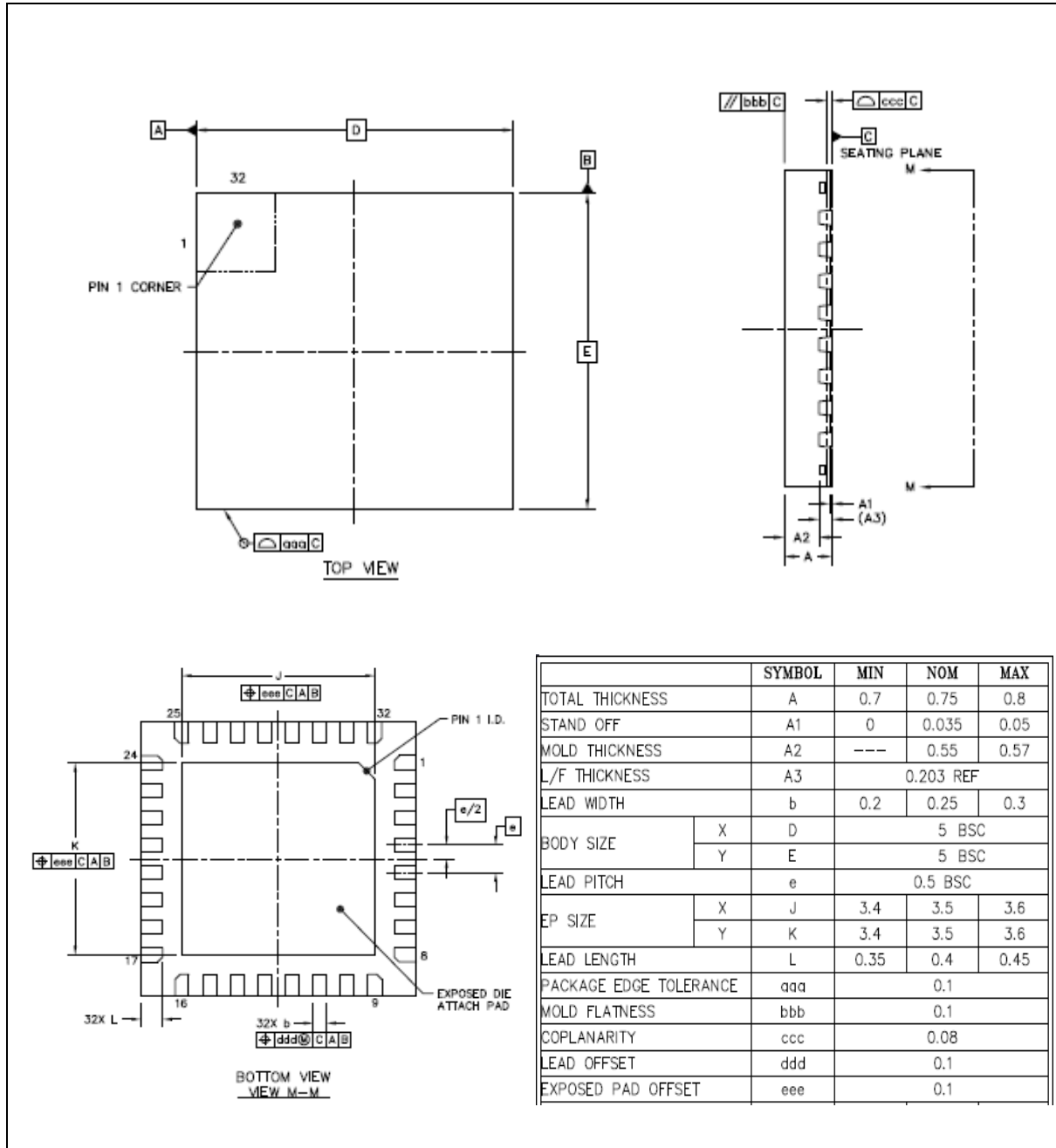

7.2 LQFP 64-pin (7x7x1.4 mm<sup>3</sup>, footprint 2.0mm)

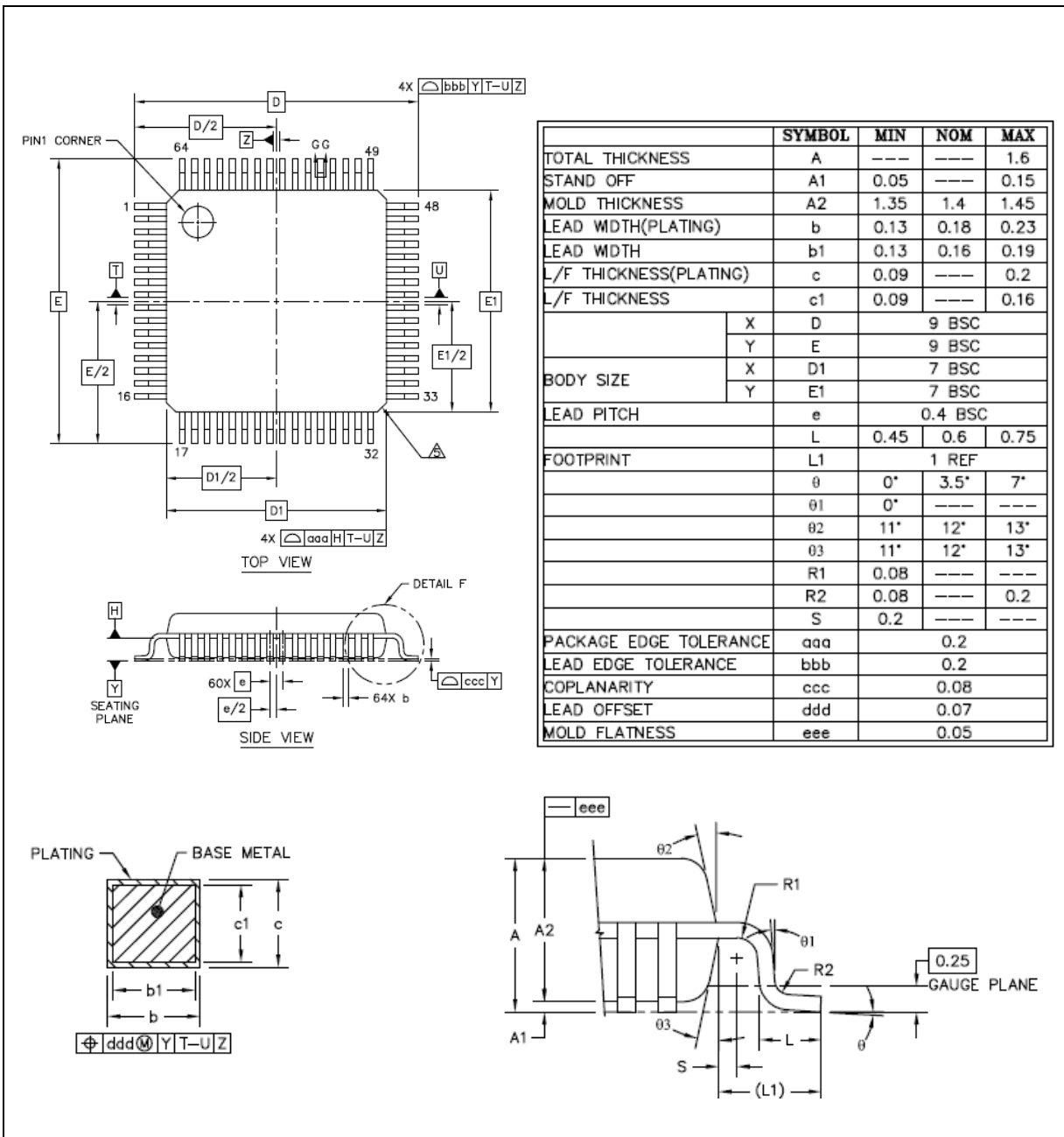

M261/M262/M263 SERIES PRODUCT BRIEF

7.3 LQFP 128-pin (14x14x1.4 mm<sup>3</sup>, footprint 2.0mm)

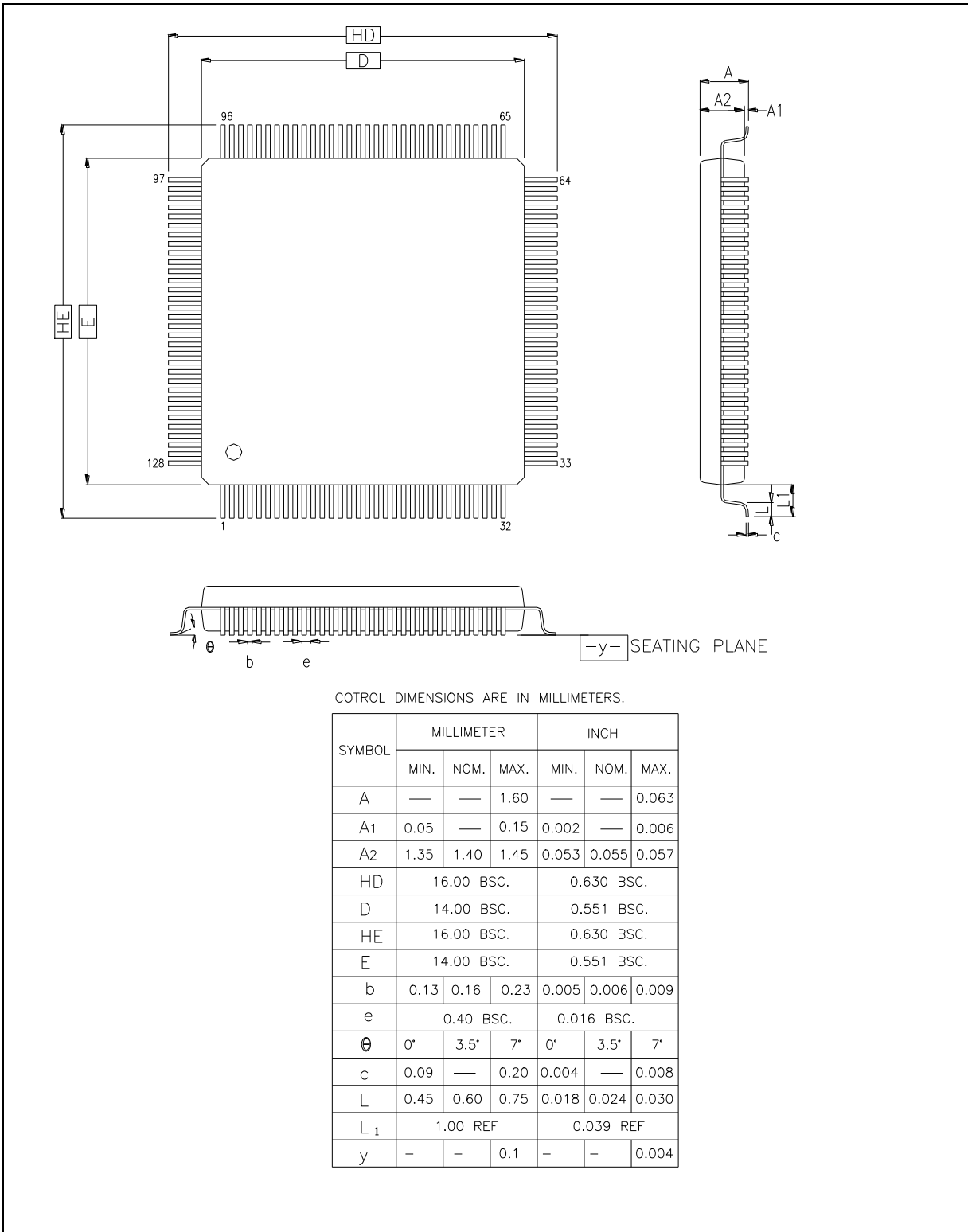

## 8 REVISION HISTORY

Date	Revision	Description
2019.02.14	0.10	Preliminary version
2019.03.28	1.00	Initial version

### Important Notice

**Nuvoton Products are neither intended nor warranted for usage in systems or equipment, any malfunction or failure of which may cause loss of human life, bodily injury or severe property damage. Such applications are deemed, "Insecure Usage".**

**Insecure usage includes, but is not limited to: equipment for surgical implementation, atomic energy control instruments, airplane or spaceship instruments, the control or operation of dynamic, brake or safety systems designed for vehicular use, traffic signal instruments, all types of safety devices, and other applications intended to support or sustain life.**

**All Insecure Usage shall be made at customer's risk, and in the event that third parties lay claims to Nuvoton as a result of customer's Insecure Usage, customer shall indemnify the damages and liabilities thus incurred by Nuvoton.**

---

*Please note that all data and specifications are subject to change without notice.  
All the trademarks of products and companies mentioned in this datasheet belong to their respective owners.*