



mbed NXP LPC1768 prototyping board

Rapid prototyping for the LPC1768 MCU

This board, which works with the groundbreaking mbed tool suite, lets you create a functioning prototype faster than ever. The tightly coupled combination of hardware and software makes it easy to explore designs quickly, so you can be more adventurous, more inventive, and more productive.

Features

- ▶ Convenient form-factor: 40-pin DIP, 0.1-inch pitch
- ▶ Drag-and-drop programming, with the board represented as a USB drive
- ▶ Best-in-class Cortex-M3 hardware
 - 100 MHz ARM with 64 KB of SRAM, 512 KB of Flash
 - Ethernet, USB OTG
 - SPI, I²C, UART, CAN
 - GPIO, PWM, ADC, DAC
- ▶ Easy-to-use online tools
 - Web-based C/C++ programming environment
 - Uses the ARM RealView compile engine
 - API-driven development using libraries with intuitive interfaces
 - Comprehensive help and online community

Benefits

- ▶ Get started right away, with nothing to install
- ▶ Get working fast, using high-level APIs
- ▶ Explore, test, and demonstrate ideas more effectively
- ▶ Write clean, compact code that's easy to modify
- ▶ Log in from anywhere, on Windows, Mac or Linux

The mbed NXP LPC1768 board lets you create prototypes without having to work with low-level microcontroller details, so you can experiment and iterate faster than ever.

Designers compose and compile embedded software using a browser-based IDE, then download it quickly and easily, using a simple drag-and-drop function, to the board's NXP Cortex-M3 microcontroller LPC1768.

Engineers new to embedded applications can use the board to prototype real products incorporating microcontrollers, while experienced engineers can use it to be more productive in early stages of development. The mbed tools are designed to let you try out new ideas quickly, in much the same way that an architect uses a pencil and paper to sketch out concepts before turning to an advanced CAD program to implement a design.

Elegant simplicity

The mbed tool has been designed for the best trade-off between versatility and immediate connectivity. The LPC1768, housed in an LQFP package, is mounted on the mbed board, which uses a 40-pin DIP with a 0.1-inch pitch. The convenient form factor works seamlessly with solderless breadboards, stripboards, and PCBs.

There is no software to install – everything, even the compiler, is online. The compiler and libraries are completely modular, so they're easy to use, yet powerful enough to take on complex, real-world applications.

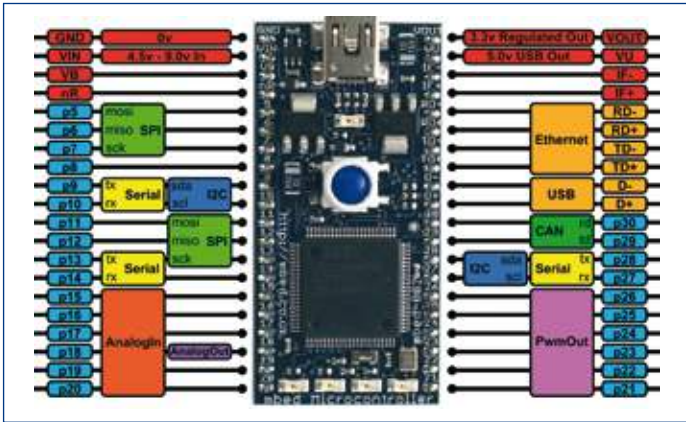

Pinout diagram of mbed NXP LPC1768 board

Hassle-free startup

Getting started is as simple as using a USB Flash drive. Simply connect the mbed NXP LPC1768 board to a Windows, Mac or Linux computer and it will appear as a USB drive. Follow the link on the board to connect to the mbed website, where you can sign up and begin designing. There are no drivers to install or setup programs to run. It's so easy, in fact, that you can have a "Hello World!" program running in as little as five minutes.

Online compiler

The mbed Compiler lets you write programs in C++ and then compile and download them to run on the mbed NXP LPC1768 microcontroller. There's no need to run an install or setup program, since the compiler runs online. Supported browsers include Internet Explorer, Firefox, Safari, or Chrome running on a Windows, Mac, or Linux PC. You can log in from anywhere and simply pick up where you left off. And, since you're working with a web-based tool, you can be confident that it's already configured and will stay up-to-date.

The compiler uses the ARM RealView compile engine, so it produces clean, efficient code that can be used free-of-charge, even in production. Existing ARM application code and middleware can be ported to the LPC1768 microcontroller, and the mbed tools can be used alongside other professional production-level tools, such as Keil MDK.

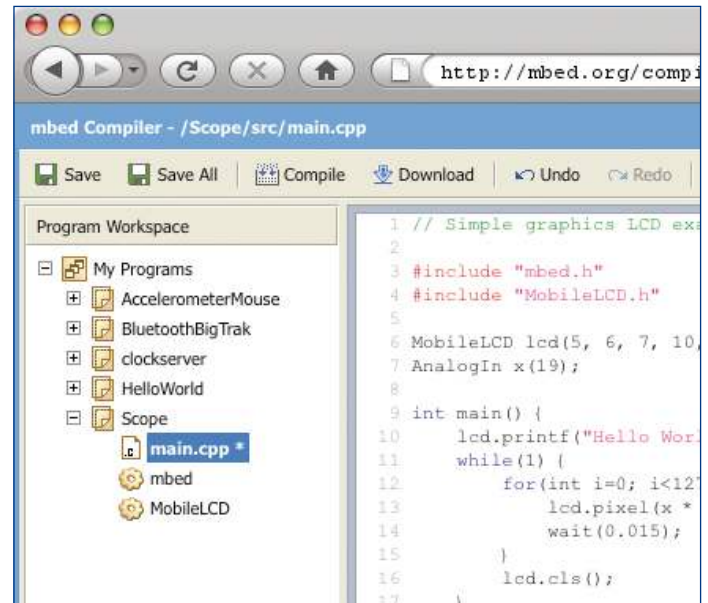

The mbed Compiler

Peripheral libraries

The mbed Library provides an API-driven approach to coding that eliminates much of the low-level work normally associated with MCU code development. You develop code using meaningful peripheral abstractions and API calls that are intuitive and already tested. That frees you up to experiment, without worrying about the implementation of the MCU core or its peripherals. You can work faster and be more creative, and can concentrate on exploring and testing the options for your design.

Rather than simply providing examples, mbed focuses on reusable library functionality, with clear interfaces and solid implementations. The core mbed Library supports the main LPC1768 peripherals, and the libraries already contributed by the mbed design community include USB, TCP/IP, and HTTP support. It's also possible to add third-party and open-source stacks.

The libraries comply with the ARM EABI and are built on the Cortex Microcontroller Software Interface Standard (CMSIS),

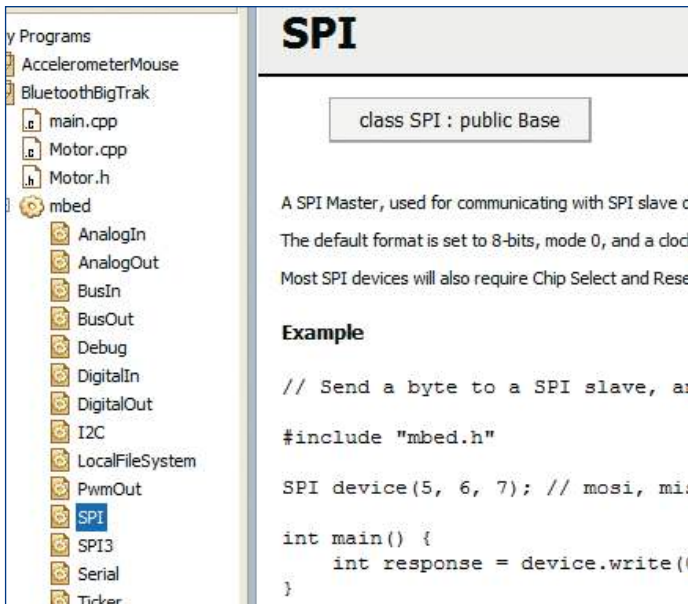

making it possible to migrate to other toolchains or implement custom code for peripheral interfaces.

LPC176x microcontrollers

The NXP microcontroller family LPC176x is a series of cost-effective, low-power Cortex-M3 devices that operate at up to 100 MHz. They feature best-in-class peripheral support, including Ethernet, USB 2.0 host/OTG/device, and CAN 2.0B. There are 512 KB of Flash memory and 64 KB of SRAM. The architecture uses a multi-layer AHB bus that allows high-bandwidth peripherals such as Ethernet and USB to run simultaneously, without impacting performance. The family is pin-compatible with NXP's 100-pin LPC236x series of ARM7-based microcontrollers.

The mbed Library

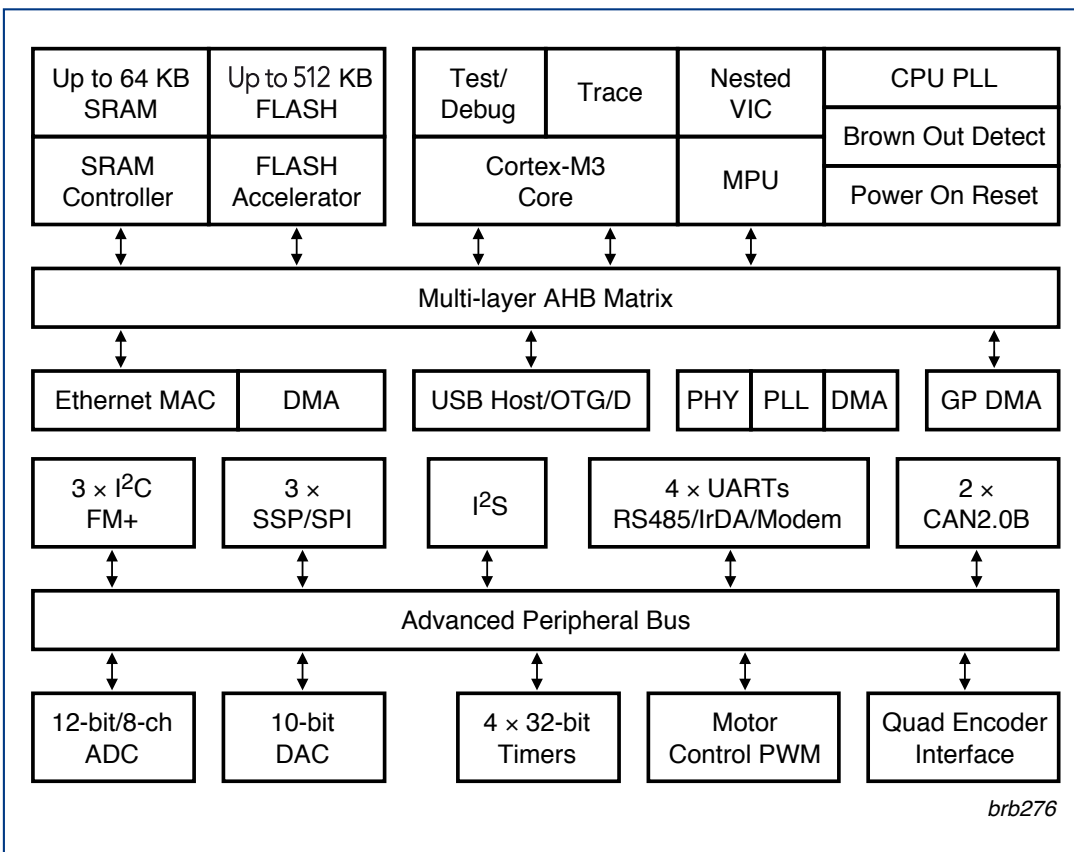

LPC1768 block diagram

LPC1768 features

ARM Cortex-M3 core	<ul style="list-style-type: none">• 100 MHz operation• Nested Vectored Interrupt Controller for fast deterministic interrupts• Wakeup Interrupt Controller allows automatic wake from any priority interrupt• Memory Protection Unit• Four reduced-power modes: sleep, deep sleep, power-down and deep power-down
Memories	<ul style="list-style-type: none">• 512 KB of Flash memory• 64 KB of SRAM
Serial peripherals	<ul style="list-style-type: none">• 10/100 Ethernet MAC• USB 2.0 full-speed device/Host/ OTG controller with on-chip PHY• Four UARTs with fractional baud rate generation, RS-48, modem control, and IrDA• Two CAN 2.0B controllers• Three SSP/SPI controllers• Three I²C-bus interfaces with one supporting Fast Mode Plus (1-Mbit/s data rates)• I²S interface for digital audio
Analog peripherals	<ul style="list-style-type: none">• 12-bit ADC with eight channels• 10-bit DAC
Other peripherals	<ul style="list-style-type: none">• Ultra-low-power (< 1 μA) RTC• General-purpose DMA controller with eight channels• Up to 70 GPIO• Motor control PWM and Quadrature Encoder Interface to support three-phase motors• Four 32-bit general-purpose timers/counters
Package	<ul style="list-style-type: none">• 100-pin LQFP (14 x 14 x 1.4 mm)

mbed

<http://mbed.org>

www.nxp.com

founded by

PHILIPS

© 2009 NXP B.V.

All rights reserved. Reproduction in whole or in part is prohibited without the prior written consent of the copyright owner. The information presented in this document does not form part of any quotation or contract, is believed to be accurate and reliable and may be changed without notice. No liability will be accepted by the publisher for any consequence of its use. Publication thereof does not convey nor imply any license under patent- or other industrial or intellectual property rights.

Date of release: September 2009

Document order number: 9397 750 16802

Printed in the Netherlands