

USB3.1, USB3.0 and USB2.0 Combo Switch**Features**

- 1:2 mux/demux for USB 3.1 Enhanced SS, USB 3.0 SS, 2.0HS, and 2.0FS signals
- Switches Tx, Rx, and Dx from USB3.0 connector
- Suitable for DisplayPort, PCIe Gen1/2/3, SATA 1.5/3/6G, SAS 1.5/3/6G and XAUI applications.
- -3dB bandwidth for enhanced superspeed channel: 10.6GHz
- Insertion Loss for enhanced superspeed channels @ 5.0 GHz: -1.5dB
- Insertion Loss for superspeed channels @ 2.5 GHz: -0.9dB
- Return loss for enhanced superspeed channels @ 5.0 GHz: -19.6dB
- Return Loss for superspeed channels @ 2.5 GHz: -26.4dB
- Low Bit-to-Bit Skew, 5ps typ(between '+' and '-' bits)
- Low Crosstalk for enhanced superspeed channels: -31.1dB @ 5.0 GHz
- Low Crosstalk for superspeed channels @2.5GHz: -33.3dB
- Low Off Isolation for enhanced superspeed channels: -17.4dB @ 5.0 GHz
- Low Off Isolation for superspeed channels @ 2.5GHz: -24.9dB
- Insertion Loss for USB – HS: -0.67dB @ 480Mbps
- Crosstalk for USB – HS: -33dB @ 480Mbps
- Off Isolation fo USB – HS: -30dB @ 480Mbps
- -3dB for USB – HS: 1.4 GHz
- V_{DD} Operating Range: 3.3V +/-10%
- ESD Tolerance: 2kV HBM
- Low channel-to-channel skew, 7ps typ
- Packaging (Pb-free & Green):
 - 32 TQFN (ZL) 3mm x 6mm x 0.75mm, 0.4mm pitch

Description

The PI3USB32212 USB3.1, USB3.0 and USB2.0 Combo Switch is a complete 1:2 switching solution for Enhanced SuperSpeed USB 3.1 signals. PI3USB32122 provides differential high-speed lanes for the USB3.1 10Gbps, USB3.0 5Gbps TX and RX lanes as well as a differential lane for 480 Mbps USB 2.0 signals.

PI3USB32212 can be used to connect two hosts to a single device or a single host to two devices.

PI3USB32212 offers excellent signal integrity for high-speed signals and low power dissipation. Insertion loss is -1.3dB and return loss is -19dB at 5 GHz (USB3.1). Insertion loss is -0.77dB and return loss is -27.8db at 2.5GHz (USB3.0).

Application

Routing of USB3.1/3.0/2.0 signals with low signal attenuation between source and sink. Applicable products include desktop PC, Notebook PC, Tablet, Docking, Telecom, DTV.

Block Diagram

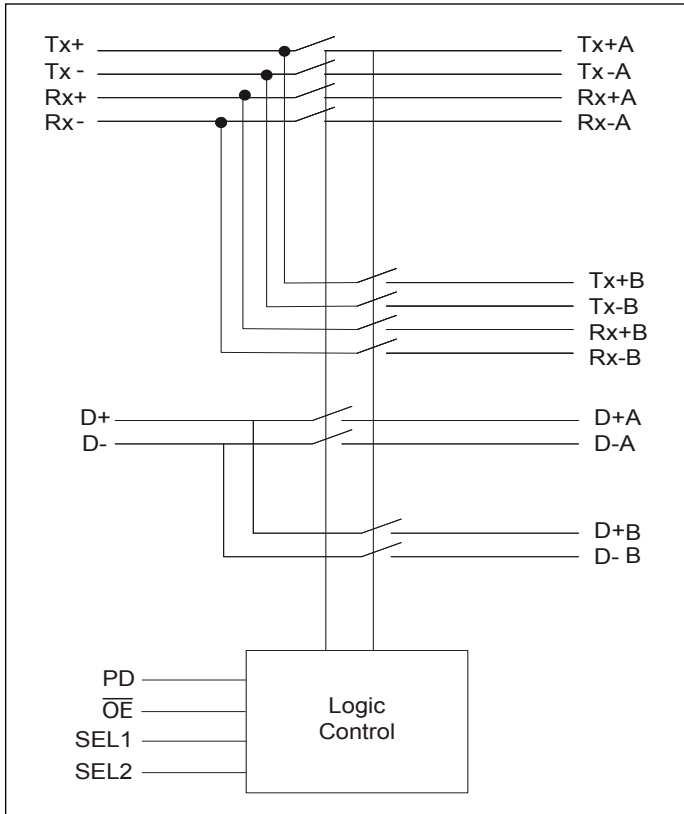

Pin Assignment (TQFN-32)

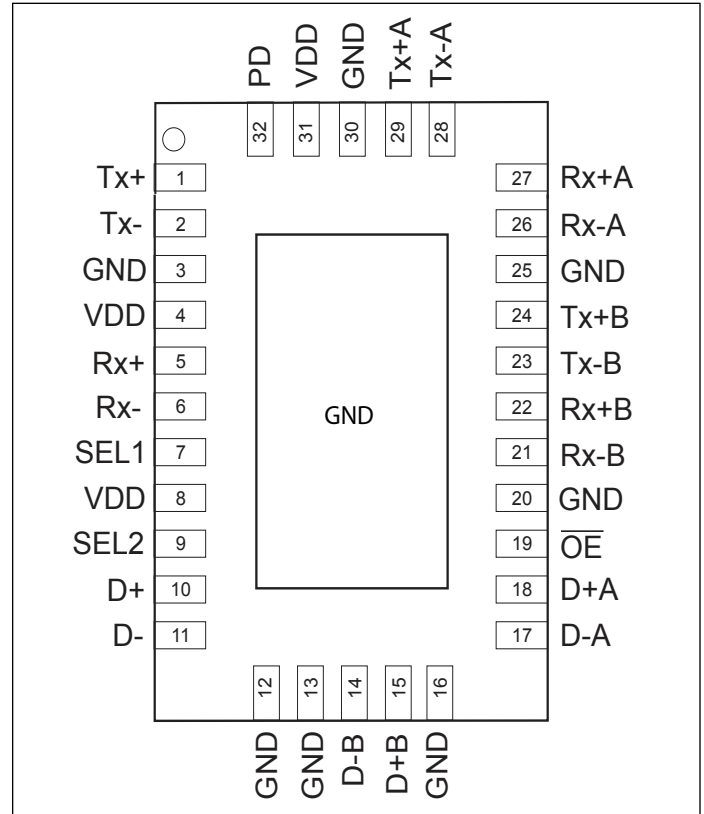

Truth Table

PD	\overline{OE}	SEL1	SEL2	Function
0	X	0	X	PortA is active for Tx & Rx
0	X	1	X	PortB is active for Tx & Rx
1	X	X	X	Both ports are Hi_Z for Tx & Rx
X	1	X	X	Both ports are High_Z for D+/D-
1	1	X	X	All channels are High_Z
X	0	X	0	PortB is active for D+/D-
X	0	X	1	PortA is active for D+/D-

Note:

1. PD & SEL1 are controls for the usb3.1 switch PD supports power down & output disable
2. \overline{OE} & SEL2 are controls for the usb2.0 switch
3. Bottom metal plate can be used as GND
4. VDD at pin8 provides power to both top and bottom die
5. All VDD need to connect to power

Pin Description

Pin#	Pin Name	Signal Type	Description
1	Tx+	I/O	Positive differential USB3.x Tx signal for COM port
2	Tx-	I/O	Negative differential USB3.x Tx signal for COM port
3	GND	Ground	Ground
4	VDD	Power	3.3V +/-10% power supply
5	Rx+	I/O	Positive differential USB3.x Rx signal for COM port
6	Rx-	I/O	Negative differential USB3.x Rx signal for COM port
7	SEL1	I	Control for USB 3.x
8	VDD	Power	3.3V +/-10% power supply
9	SEL2	I	Control for USB 2.0
10	D+	I/O	Positive differential USB 2.0 COM port
11	D-	I/O	Negative differential USB2.0 COM port
12	GND	Ground	Ground
13	GND	Ground	Ground
14	D-B	I/O	Negative differential USB2.0 signal for port 1
15	D+B	I/O	Positive differential USB2.0 signal for port 1
16	GND	Ground	Ground
17	D-A	I/O	Negative differential USB2.0 signal for port 0
18	D+A	I/O	Positive differential USB2.0 signal for port 0
19	\overline{OE}	I	Control for USB 2.0
20	GND	Ground	Ground
21	Rx-B	I/O	Negative differential USB 3.x signal for port 0
22	Rx+B	I/O	Positive differential USB 3.x signal for port 0
23	Tx-B	I/O	Negative differential USB3.x Rx signal for port 0
24	Tx+B	I/O	Positive differential USB3.x Tx signal for port 0
25	GND	Ground	Ground
26	Rx-A	I/O	Negative differential USB3.xRx signal for port 1
27	Rx+A	I/O	Positive differential USB3.x Rx signal for port 1
28	Tx-A	I/O	Negative differential USB3.x Rx signal for port 1
29	Tx+A	I/O	Positive differential USB3.x Tx signal for port 1
30	GND	Ground	Ground
31	VDD	Power	3.3V +/-10% power supply
32	PD	I	Power down and disable USB3.x output

Maximum Ratings

(Above which useful life may be impaired. For user guidelines, not tested.)

Storage Temperature	-65°C to +150°C
Supply Voltage to Ground Potential	-0.5V to +4.0V
DC Input Voltage, USB3	-0.5V to 1.5V
DC Input Voltage, USB2	-0.5V to V _{DD}
DC Output Current	120mA
Power Dissipation	0.5W
ESD.....	2KV HBM

Note: Stresses greater than those listed under MAXIMUM RATINGS may cause permanent damage to the device. This is a stress rating only and functional operation of the device at these or any other conditions above those indicated in the operational sections of this specification is not implied. Exposure to absolute maximum rating conditions for extended periods may affect reliability.

DC Electrical Characteristics for Switching over Operating Range

(T_A = -40°C to +85°C, V_{DD} = 3.3V ±10%)

Parameter	Description	Test Conditions ⁽¹⁾	Min.	Typ. ⁽¹⁾	Max.	Units
V _{IH}	Input HIGH Voltage	Guaranteed HIGH level	0.65*V _{DD}			V
V _{IL}	Input LOW Voltage	Guaranteed LOW level			0.6	
V _{IK}	Clamp Diode Voltage, Dx	V _{DD} = Max., I _{IN} = -18mA		-0.7	-1.2	
I _{IH}	Input HIGH Current	V _{DD} = Max., V _{IN} = V _{DD}			±5	µA
I _{IL}	Input LOW Current	V _{DD} = Max., V _{IN} = GND			±5	
R _{ON_SS}	On resistance between input to output for SuperSpeed signals	V _{DD} = 3.3V, V _{input} = 0V to 1V, I _{INPUT} = 20mA		10	13	Ohm
R _{ON_FS}	On resistance between input to output for USB2.0 FS signals (D+/D-)	V _{DD} = 3.3V, V _{input} = 0 to 3.3V, I _{INPUT} = 20mA		7	9	Ohm
R _{ON_HS}	On resistance between input to output for USB2.0 HS signals (D+/D-)	V _{DD} = 3.3V, V _{input} = -0.4V to +0.4V, I _{INPUT} = 20mA		4	6	Ohm

Power Supply Characteristics (T_A = -40°C to +85°C)

Parameter	Description	Test Conditions ⁽¹⁾	Min.	Typ. ⁽¹⁾	Max.	Units
I _{CC}	Quiescent Power Supply Current	V _{DD} = Max., V _{IN} = GND or V _{DD}			500	µA

Dynamic Electrical Characteristics over Operating Range ($T_A = -40^\circ$ to $+85^\circ\text{C}$, $V_{DD} = 3.3\text{V} \pm 10\%$)

Parameter	Description	Test Conditions		Min.	Typ.	Max.	Units
DDXT	Differential Crosstalk on SuperSpeed Channels	See Fig. 1 for Measurement Setup	f= 2.5 GHz		-33.3		dB
			f= 4.0 GHz		-31.9		
			f= 5.0 GHz		-31.1		
DDOI	Differential OFF Isolation on SuperSpeed Channels	See Fig. 2 for Measurement Setup,	f= 2.5 GHz		-24.9		
			f= 4.0 GHz		-18.9		
			f= 5.0 GHz		-17.4		
DDIL	Differential Insertion Loss on SuperSpeed Channels	f= 2.5 GHz			-0.9		dB
		f= 4.0 GHz			-1.3		
		f= 5.0 GHz			-1.5		
R_{loss}	Differential Return Loss on SuperSpeed channels	f= 2.5 GHz			-26.4		dB
		f= 4.0 GHz			-22.4		
		f= 5.0 GHz			-19.6		
BW	3db Bandwidth on SuperSpeed channels				10.6		GHz
$X_{\text{TALK-USB2 HS}}$	Crosstalk	$R_L = 50\Omega$	f= 240 MHz	-35	-39		dB
			f= 825 MHz	-25	-28		
$O_{\text{IRR-USB2 HS}}$	OFF Isolation		f= 240 MHz	-29	-32		
			f= 825 MHz	-20	-23		
$BW_{\text{-USB2 HS}}$	-3dB Bandwidth	$R_L = 50\Omega$		1100	1400		MHz
$BW_{\text{-USB2 HS}}$	-0.5dB Bandwidth	$R_L = 50\Omega$		150	400		MHz
$IN_{\text{-USB2 HS}}$	Insertion Loss	f= 240 MHz			0.47	0.67	dB
		f= 825 MHz			1.8	2.4	
		f= 1.0 GHz			2.2	2.6	
		f= 1.125 GHz			2.4	3.0	

Note:

1. For Max. or Min. conditions, use appropriate value specified under Electrical Characteristics for the applicable device type.
2. Typical values are at $V_{DD} = 3.3\text{V}$, $T_A = 25^\circ\text{C}$ ambient and maximum loading.

Switching Characteristics ($T_A = -40^\circ$ to $+85^\circ\text{C}$, $V_{DD} = 3.3\text{V} \pm 10\%$)

Parameter	Description	Min.	Typ.	Max.	Units
T_{pd}	Propagation delay (input pin to output pin)	USB3	80		ps
		USB-HS	250		
$t_{\text{b-b}}$	Bit-to-bit skew within the same differential pair			10	ps
$t_{\text{ch-ch}}$	Channel-to-channel skew			20	ps
T_{sw}	Switching time between paths (toggling SEL1, SEL2)	2		100	ns

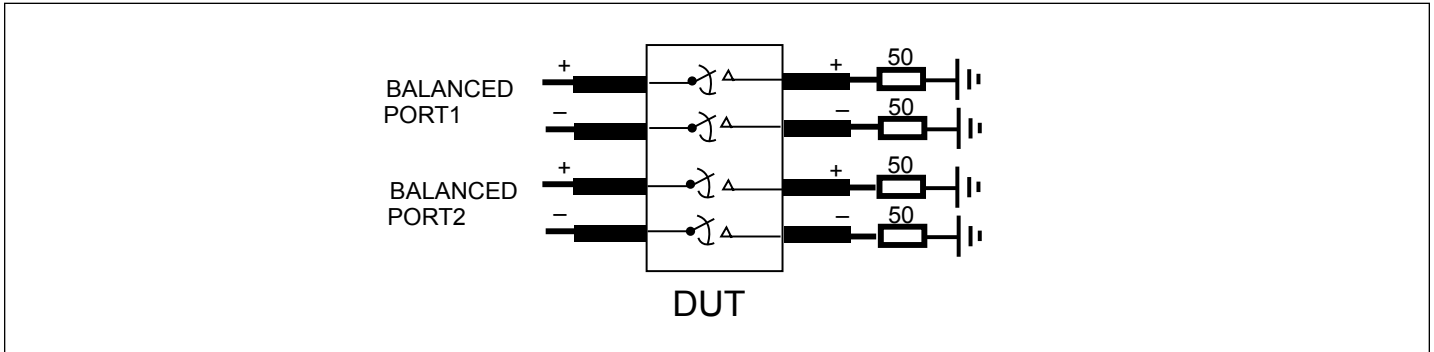

Fig 1. Crosstalk Setup

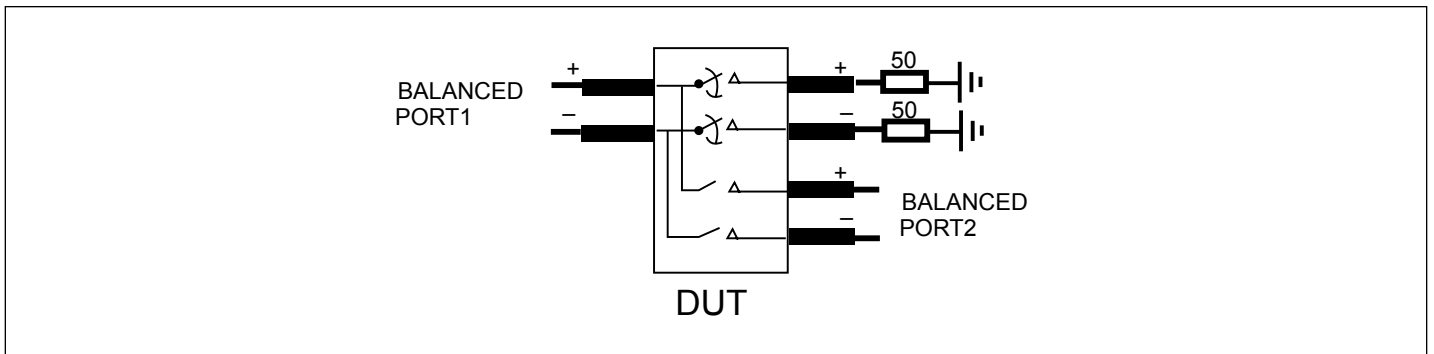

Fig 2. Off-isolation setup

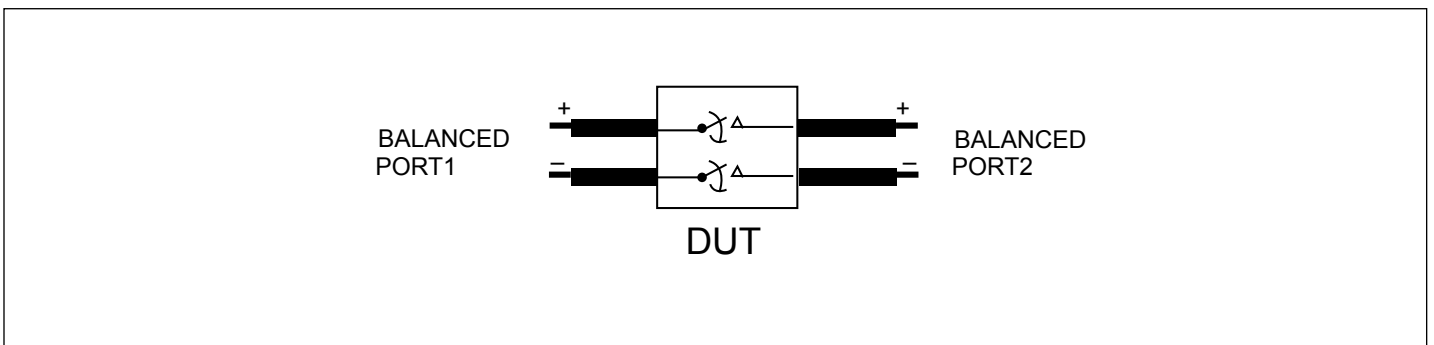

Fig 3. Differential Insertion Loss set up



Fig 4. Differential Crosstalk – Super Speed



Fig 5. Differential Off Isolation – Super Speed

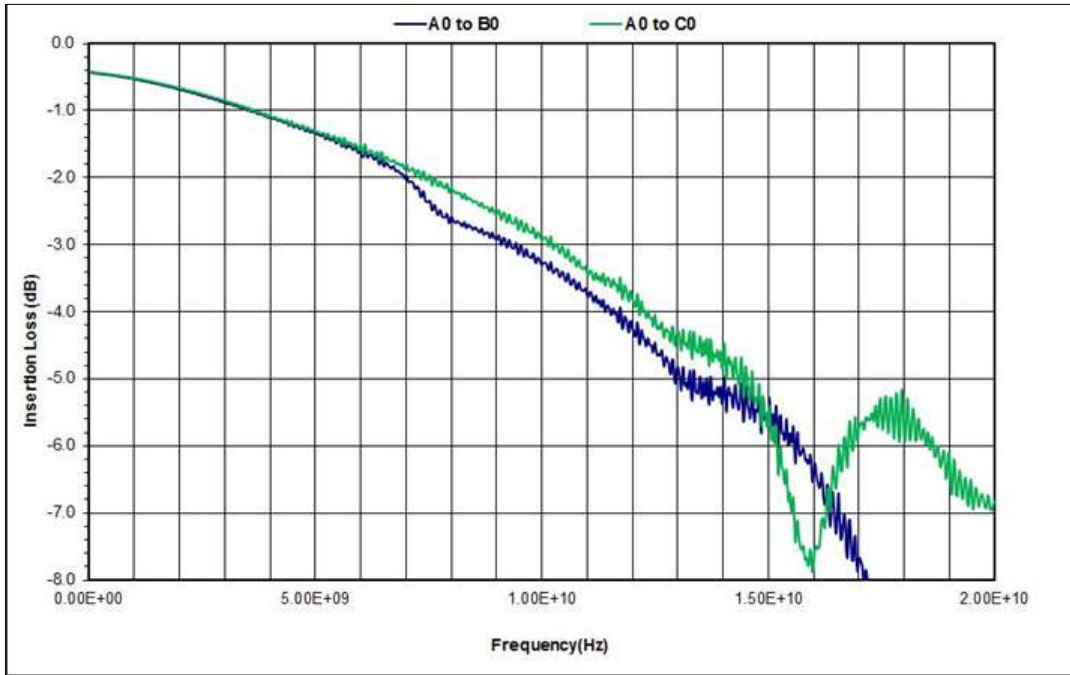

Fig 6. Differential Insertion Loss – Super Speed

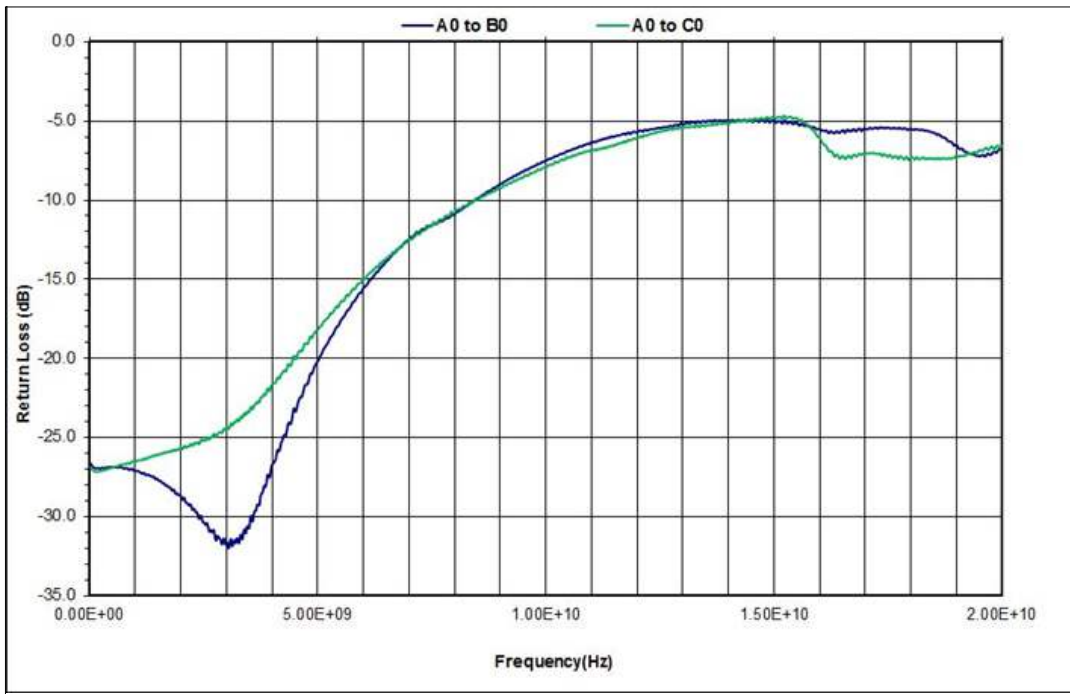

Fig 7. Differential Return Loss – Super Speed

PI3USB32212

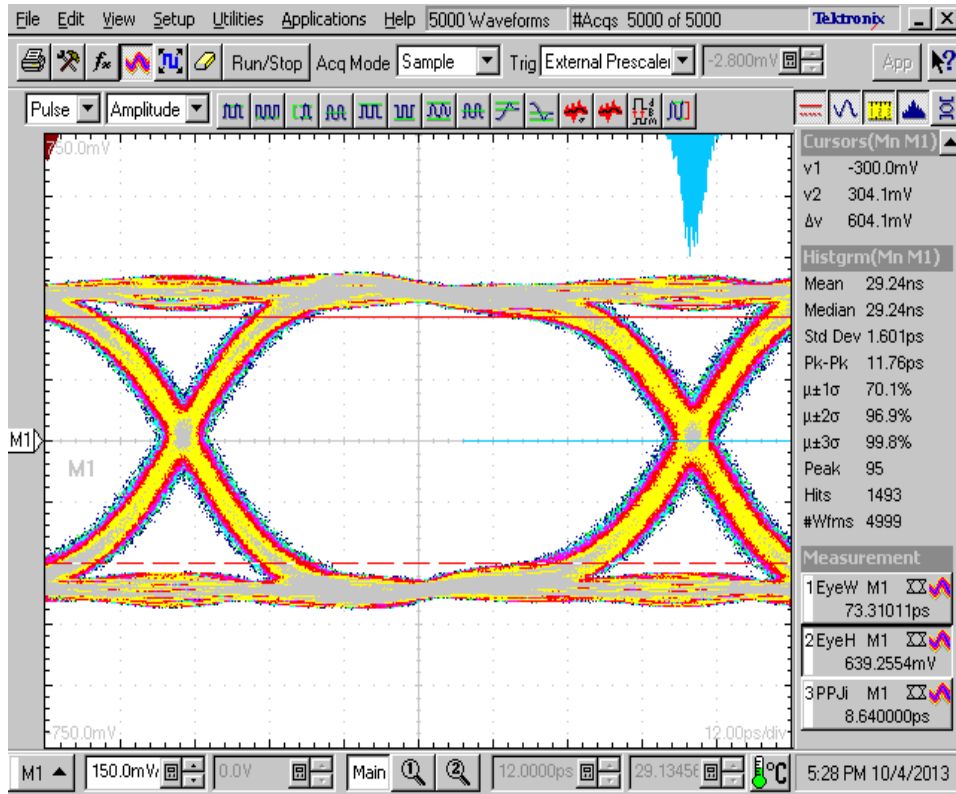

Fig 8. 12Gbps Eye without PI3USB32212

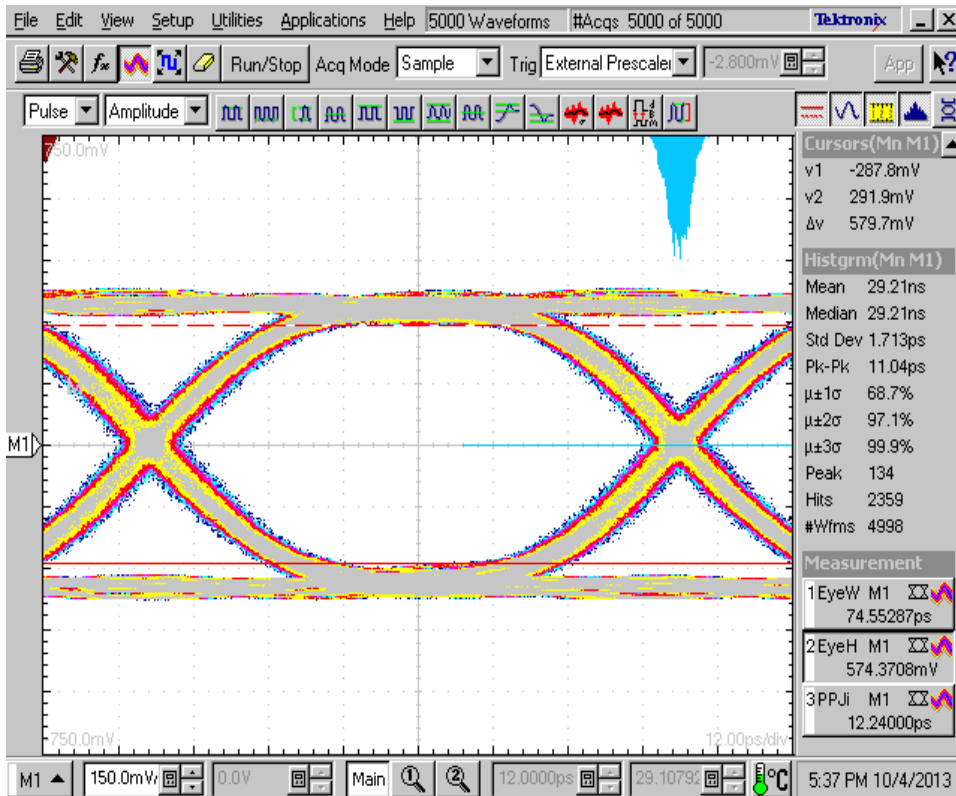

Fig 9. 12Gbps Eye with PI3USB32212

PI3USB32212

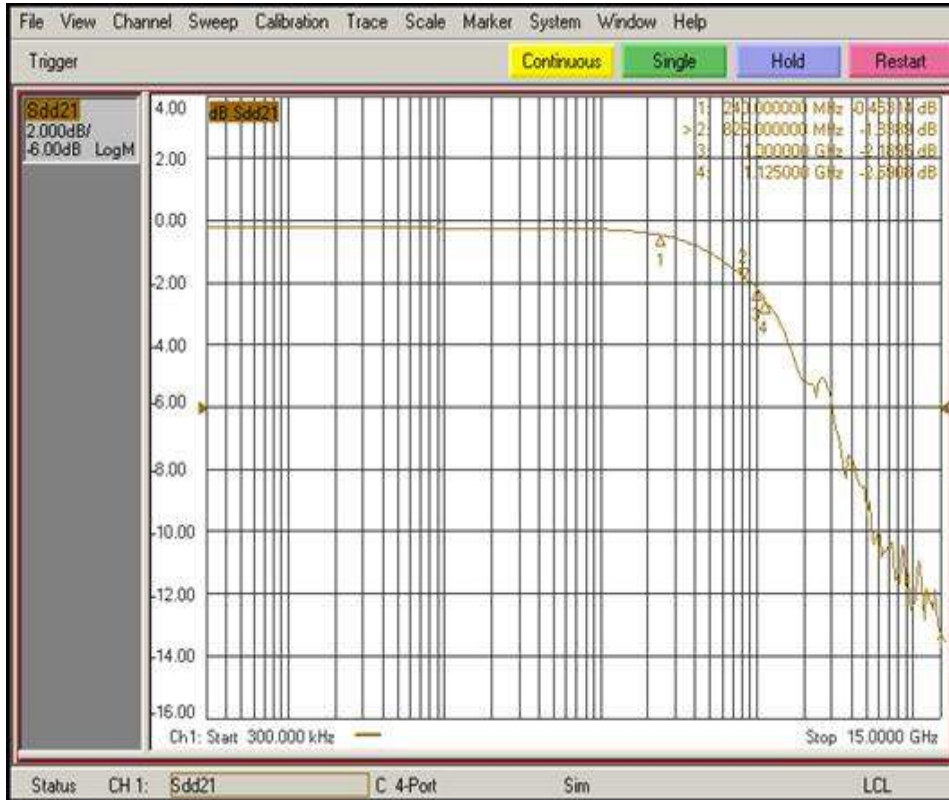
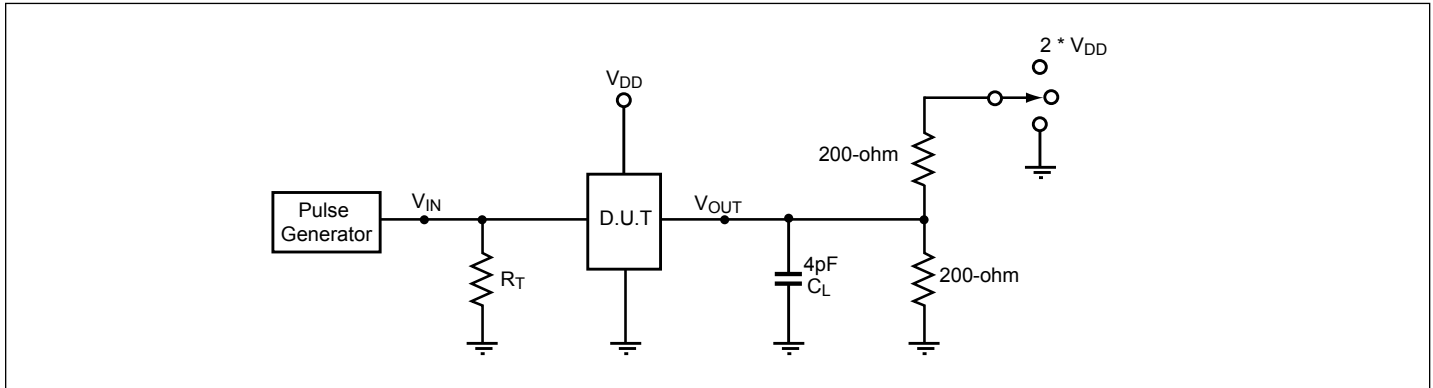

Fig 10. Differential Insertion loss, $V_{DD} = 3.3V$ – USB2 HS

Test Circuit for Electrical Characteristics(1-5)



Notes:

1. C_L = Load capacitance: includes jig and probe capacitance.
2. R_T = Termination resistance: should be equal to Z_{OUT} of the Pulse Generator
3. Output 1 is for an output with internal conditions such that the output is low except when disabled by the output control.
4. Output 2 is for an output with internal conditions such that the output is high except when disabled by the output control.
5. All input impulses are supplied by generators having the following characteristics: $PRR \leq \text{MHz}$, $Z_O = 50\Omega$, $t_R \leq 2.5\text{ns}$, $t_F \leq 2.5\text{ns}$.
6. The outputs are measured one at a time with one transition per measurement.

Switching Waveforms

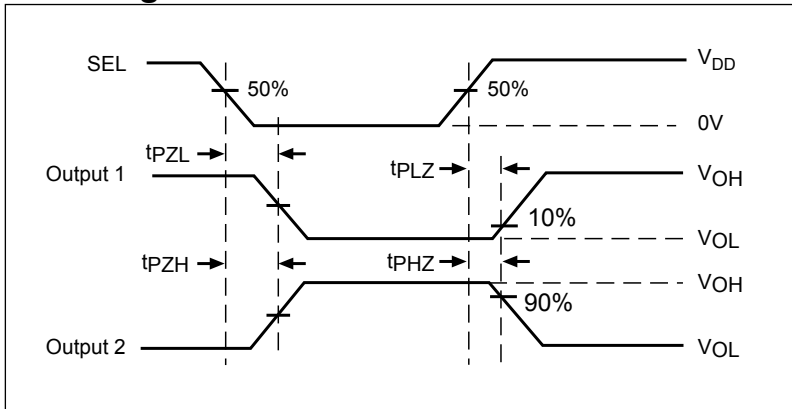

Voltage Waveforms Enable and Disable Times

Switch Positions

Test	Switch
t_{PLZ} , t_{PZL} (output on B-side)	$2 * V_{DD}$
t_{PHZ} , t_{PZH} (output on B-side)	GND
Prop Delay	Open

Test Circuit for Dynamic Electrical Characteristics

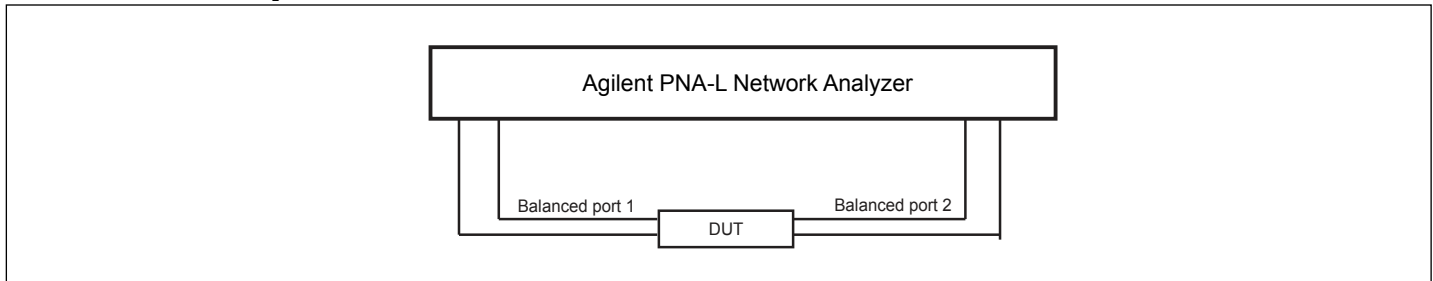

Packaging Mechanical: 32-TQFN (ZL)

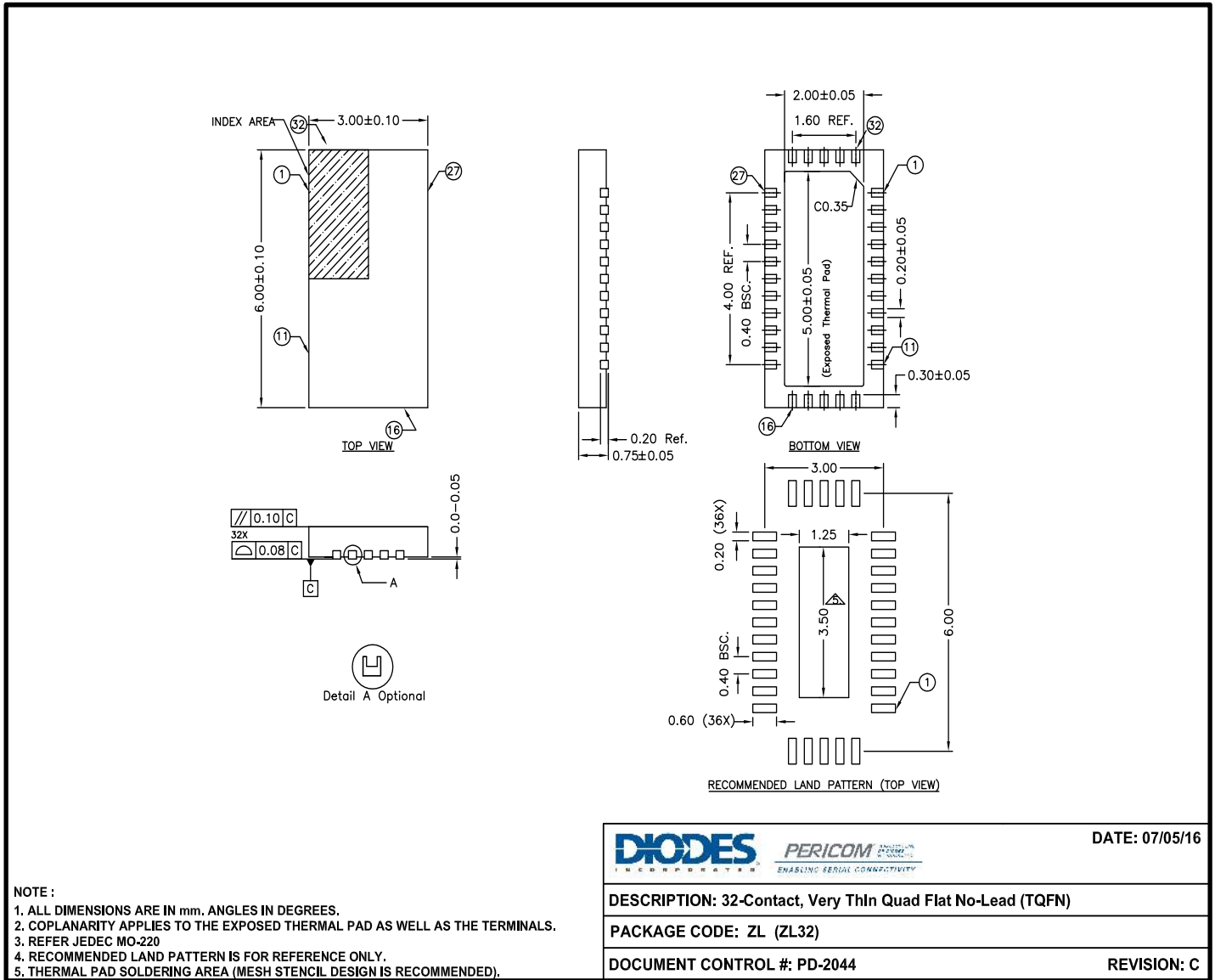

NOTE:
 1. ALL DIMENSIONS ARE IN mm. ANGLES IN DEGREES.
 2. COPLANARITY APPLIES TO THE EXPOSED THERMAL PAD AS WELL AS THE TERMINALS.
 3. REFER JEDEC MO-220
 4. RECOMMENDED LAND PATTERN IS FOR REFERENCE ONLY.
 5. THERMAL PAD SOLDERING AREA (MESH STENCIL DESIGN IS RECOMMENDED).

		DATE: 07/05/16
DESCRIPTION: 32-Contact, Very Thin Quad Flat No-Lead (TQFN)		
PACKAGE CODE: ZL (ZL32)		
DOCUMENT CONTROL #: PD-2044		REVISION: C

16-0142

For latest package info.
 please check: <http://www.diodes.com/design/support/packaging/pericom-packaging/packaging-mechanicals-and-thermal-characteristics/>

Ordering Information

Ordering Code	Package Code	Package Description
PI3USB32212ZLEX	ZL	32-contact, Very Thin Quad Flat No-Lead (TQFN) Copper Wire
PI3USB32212ZLEX+DA	ZL	32-contact, Very Thin Quad Flat No-Lead (TQFN) Gold Wire

- Notes:**
- Thermal characteristics can be found on the company web site at www.diodes.com/design/support/packaging/
 - E = Pb-free and Green
 - X suffix = Tape/Reel

IMPORTANT NOTICE

DIODES INCORPORATED MAKES NO WARRANTY OF ANY KIND, EXPRESS OR IMPLIED, WITH REGARDS TO THIS DOCUMENT, INCLUDING, BUT NOT LIMITED TO, THE IMPLIED WARRANTIES OF MERCHANTABILITY AND FITNESS FOR A PARTICULAR PURPOSE (AND THEIR EQUIVALENTS UNDER THE LAWS OF ANY JURISDICTION).

Diodes Incorporated and its subsidiaries reserve the right to make modifications, enhancements, improvements, corrections or other changes without further notice to this document and any product described herein. Diodes Incorporated does not assume any liability arising out of the application or use of this document or any product described herein; neither does Diodes Incorporated convey any license under its patent or trademark rights, nor the rights of others. Any Customer or user of this document or products described herein in such applications shall assume all risks of such use and will agree to hold Diodes Incorporated and all the companies whose products are represented on Diodes Incorporated website, harmless against all damages.

Diodes Incorporated does not warrant or accept any liability whatsoever in respect of any products purchased through unauthorized sales channel.

Should Customers purchase or use Diodes Incorporated products for any unintended or unauthorized application, Customers shall indemnify and hold Diodes Incorporated and its representatives harmless against all claims, damages, expenses, and attorney fees arising out of, directly or indirectly, any claim of personal injury or death associated with such unintended or unauthorized application.

Products described herein may be covered by one or more United States, international or foreign patents pending. Product names and markings noted herein may also be covered by one or more United States, international or foreign trademarks.

This document is written in English but may be translated into multiple languages for reference. Only the English version of this document is the final and definitive format released by Diodes Incorporated.

LIFE SUPPORT

Diodes Incorporated products are specifically not authorized for use as critical components in life support devices or systems without the express written approval of the Chief Executive Officer of Diodes Incorporated. As used herein:

A. Life support devices or systems are devices or systems which:

1. are intended to implant into the body, or

2. support or sustain life and whose failure to perform when properly used in accordance with instructions for use provided in the labeling can be reasonably expected to result in significant injury to the user.

B. A critical component is any component in a life support device or system whose failure to perform can be reasonably expected to cause the failure of the life support device or to affect its safety or effectiveness.

Customers represent that they have all necessary expertise in the safety and regulatory ramifications of their life support devices or systems, and acknowledge and agree that they are solely responsible for all legal, regulatory and safety-related requirements concerning their products and any use of Diodes Incorporated products in such safety-critical, life support devices or systems, notwithstanding any devices- or systems-related information or support that may be provided by Diodes Incorporated. Further, Customers must fully indemnify Diodes Incorporated and its representatives against any damages arising out of the use of Diodes Incorporated products in such safety-critical, life support devices or systems.

Copyright © 2016, Diodes Incorporated

www.diodes.com