

	10	9		8		7			5	4	3	2	
	QTY. OF CIRC. "XX"	DIM. "A"	DIM. "B"	DIM. "C"	DIM. "D"	MATERIAL # (STANDARD)							
F	02	25.1 (1.99)	6.35 (1.250)	19.05 (1.750)	14.4 (1.57)	38600-6402							
F	03	31.5 (1.24)	12.70 (1.500)	25.40 (1.000)	20.8 (1.82)	38600-6403							
F	04	37.8 (1.49)	19.05 (1.750)	31.75 (1.250)	27.1 (1.07)	38600-6404							
F	05	44.2 (1.74)	25.40 (1.000)	38.10 (1.500)	33.5 (1.32)	38600-6405							
F	06	50.5 (1.99)	31.75 (1.250)	44.45 (1.750)	39.8 (1.57)	38600-6406							
F	07	56.9 (2.24)	38.10 (1.500)	50.80 (2.000)	46.2 (1.82)	38600-6407							
F	08	63.2 (2.49)	44.45 (1.750)	57.15 (2.250)	52.5 (2.07)	38600-6408							
E	09	69.6 (2.74)	50.80 (2.000)	63.50 (2.500)	58.9 (2.32)	38600-6409							
E	10	75.9 (2.99)	57.15 (2.250)	69.85 (2.750)	65.2 (2.57)	38600-6410							
E	11	82.3 (3.24)	63.50 (2.500)	76.20 (3.000)	71.6 (2.82)	38600-6411							
E	12	88.6 (3.49)	69.85 (2.750)	82.55 (3.250)	77.9 (3.07)	38600-6412							
E	13	95.0 (3.74)	76.20 (3.000)	88.90 (3.500)	84.3 (3.32)	38600-6413							
E	14	101.3 (3.99)	82.55 (3.250)	95.25 (3.750)	90.6 (3.57)	38600-6414							
E	15	107.7 (4.24)	88.90 (3.500)	101.60 (4.000)	97.0 (3.82)	38600-6415							
E	16	114.0 (4.49)	95.25 (3.750)	107.95 (4.250)	103.3 (4.07)	38600-6416							
D	17	120.4 (4.74)	101.60 (4.000)	114.30 (4.500)	109.7 (4.32)	38600-6417							
D	18	126.7 (4.99)	107.95 (4.250)	120.65 (4.750)	116.0 (4.57)	38600-6418							
D	19	133.1 (5.24)	114.30 (4.500)	127.00 (5.000)	122.4 (4.82)	38600-6419							
D	20	139.4 (5.49)	120.65 (4.750)	133.35 (5.250)	128.7 (5.07)	38600-6420							
D	21	145.8 (5.74)	127.00 (5.000)	139.70 (5.500)	135.1 (5.32)	38600-6421							
D	22	152.1 (5.99)	133.35 (5.250)	146.05 (5.750)	141.4 (5.57)	38600-6422							
D	23	158.5 (6.24)	139.70 (5.500)	152.40 (6.000)	147.8 (5.82)	38600-6423							
D	24	164.8 (6.49)	146.05 (5.750)	158.75 (6.250)	154.1 (6.07)	38600-6424							
D	25	171.2 (6.74)	152.40 (6.000)	165.10 (6.500)	160.5 (6.32)	38600-6425							
D	26	177.5 (6.99)	158.75 (6.250)	171.45 (6.750)	166.8 (6.57)	38600-6426							
D	27	183.9 (7.24)	165.10 (6.500)	177.80 (7.000)	173.2 (6.82)	38600-6427							
D	28	190.2 (7.49)	171.45 (6.750)	184.15 (7.250)	179.5 (7.07)	38600-6428							
C	29	196.6 (7.74)	177.80 (7.000)	190.50 (7.500)	185.9 (7.32)	38600-6429							
C	30	202.9 (7.99)	184.15 (7.250)	196.85 (7.750)	192.2 (7.57)	38600-6430							
C	31	209.3 (8.24)	190.50 (7.500)	203.20 (8.000)	198.6 (7.82)	38600-6431							
C	32	215.6 (8.49)	196.85 (7.750)	209.55 (8.250)	204.9 (8.07)	38600-6432							

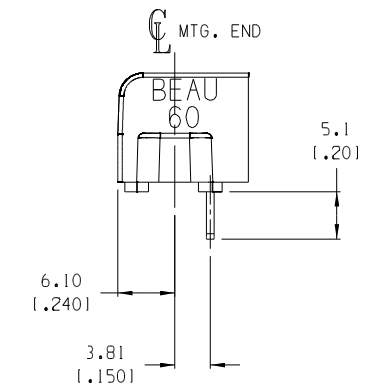

- NOTES:
1. MATERIAL: SEE TABLE
  2. FINISHES: SEE TABLE
  3. PRODUCT SPECIFICATION: NOT REQUIRED
  4. PACKAGING: NOT REQUIRED
  5. MATES WITH: NONE
  6. "XX" REFERS TO THE QUANTITY OF CIRCUITS.

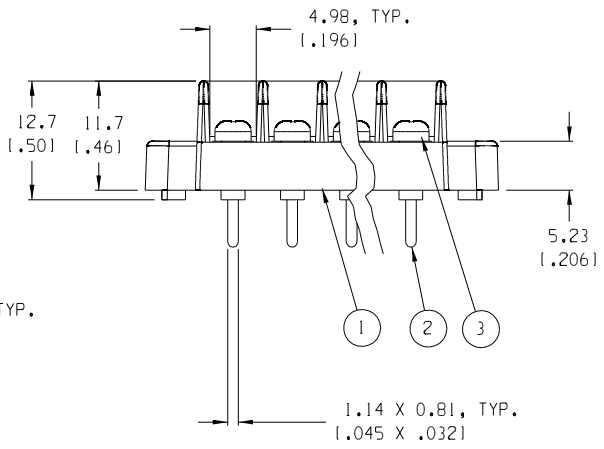
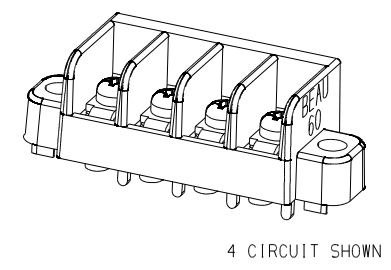
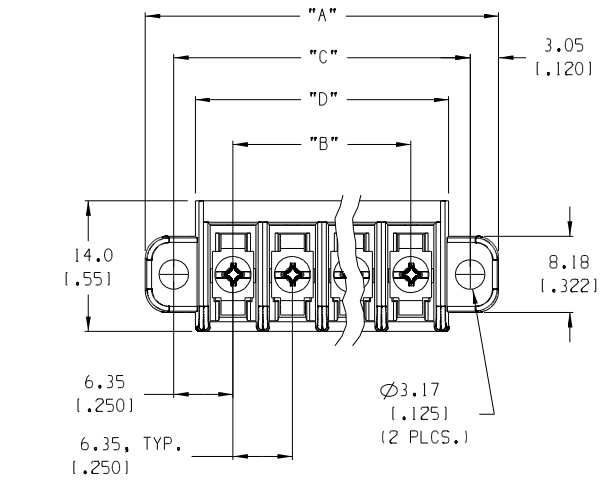
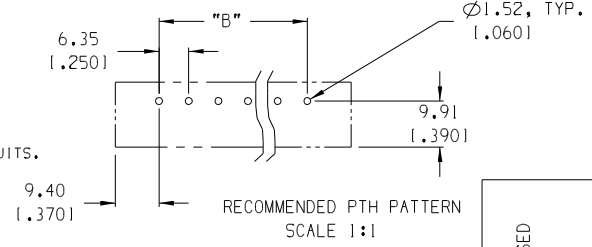

3	XX	SCREW, #3-48, FILLISTER HEAD, PHIL-SLOT	BRASS	NICKEL PLATE
2	XX	TERMINAL, PC	BRASS	TIN PLATE
1	I	INSULATOR, SR, CLOSED SIDE	BLACK	THERMOPLASTIC
ITEM	QTY.	DESCRIPTION	MATERIAL	FINISH

EC NO. RELEASED CLY DRW: CH'K: APPR:	DESCRIPTION REV	QUALITY SYMBOLS MAJOR CRITICAL SPC	GENERAL TOLERANCES: (UNLESS SPECIFIED) mm      INCH 4 PLACES ±.0015 3 PLACES ±.038 ±.005 2 PLACES ±.13 ±.01 1 PLACE ±.3 ANGULAR: ±2°	SCALE 2:1 DESIGN UNITS <input type="checkbox"/> mm <input checked="" type="checkbox"/> INCH DRAWN BY & DATE C. YORK 11-22-04 CHECKED BY & DATE APPROVED BY & DATE	THIRD ANGLE PROJECTION TITLE: 6.35mm (.250") SR BTS ASSY, CLOSED SIDE MOLEX INCORPORATED	
		CAD FILENAME 605XX	MATERIAL NO. SEE CHART	DRAWING NO. SD-38600-002	SHEET NO. 1 OF 1	
		DRAFT WHERE APPLICABLE MUST REMAIN WITHIN DIMENSIONS			THIS DRAWING CONTAINS INFORMATION THAT IS PROPRIETARY TO MOLEX INCORPORATED AND SHOULD NOT BE USED WITHOUT WRITTEN PERMISSION.	SIZE B