

Si84xx CMOS DIGITAL ISOLATOR-BASED SERIAL INTERFACE USER'S GUIDE

1. Introduction

Si84xx devices are CMOS-based galvanic isolators (1 kV/2.5 kV/5 kV) designed for industrial, commercial, and medical isolation applications. They are available in various channel counts (1/2/3/4/5/6), speeds (1 and 150 Mbps), and options in two package options (narrow and wide body SOIC). They are also available in unidirectional or bidirectional (I²C) channels option.

2. Kit Contents

The Si84xxCOM Evaluation Board contains the following items:

- Si84xxCOM evaluation board show casing:
 - Si8442AB 4-channel unidirectional 1 Mbps digital isolator, narrow body, 2.5 kV
 - Si8421BB 2-channel unidirectional 150 Mbps digital isolator, narrow body, 2.5 kV
 - Si8421AD 2-channel unidirectional 1 Mbps digital isolator, wide body, 5 kV*

***Note:** The creepage and clearance are defined by the narrow-body SOIC (2.5 kV) isolators used in the EVB and must NOT be used for 5 kV isolation testing.

2.1. Hardware Overview

The Si84xxCOM Evaluation Board implements the isolated physical layer for RS232, RS422/485, and CAN bus serial transceivers. Key features include:

- Isolated RS232 transceiver: Maximum data rate of 1 Mbps. Isolated TXD, RXD, RTS, and CTS signals with DB9 connector interface.
- Isolated 4 Wire RS422/485: Maximum data rate of 52 Mbps; failsafe full duplex with passive flow control. DB9 and RJ45 connectors.
- Isolated CAN Bus: Maximum data rate of 1 Mbps, which implements the ISO 11898-3 physical layer and DB9 connector.

A top-level hardware block diagram is shown in Figure 1. The RS232 and RS422/RS485 isolated transceivers operate as a repeater, and the CAN Bus interface operates as an isolated controller-side interface.

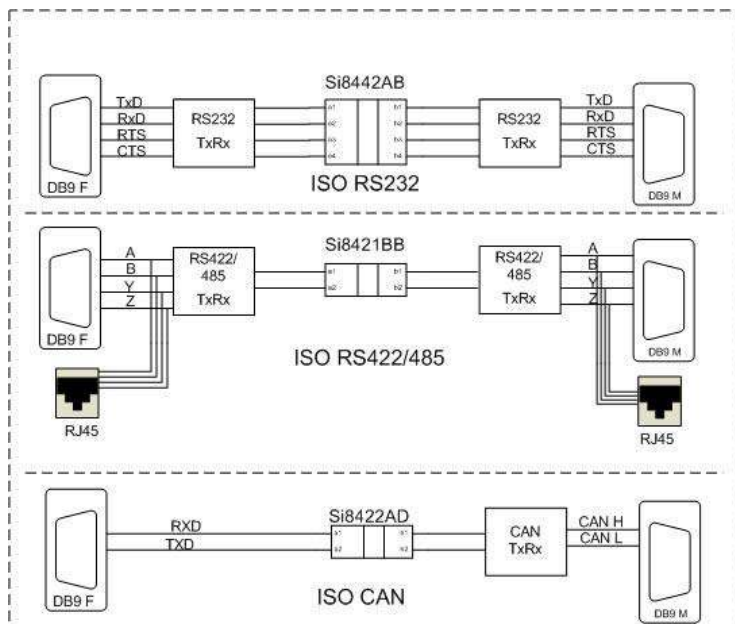

Figure 1. Top-Level Hardware Overview

Si84xxCOM-EVB

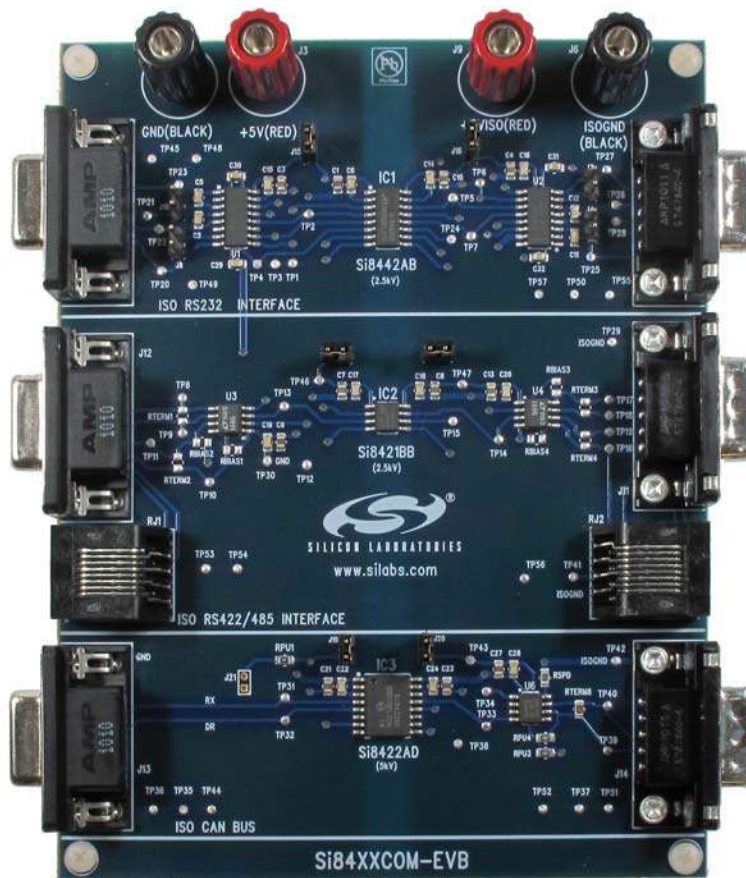

Figure 2. Si84xxCOM Evaluation Board

The evaluation board photo of Figure 2 shows the Silicon Labs Si844xx digital isolators placed at the center of the board. The RS232 and 422/485 isolated transceivers are implemented with narrow-body, 2.5 kV Si8442AB and Si8421BB digital isolators. The medical grade CAN bus interface is implemented with a wide-body Si8422AD digital isolator rated at 5 kV.*

***Note:** The creepage and clearance are defined by the narrow-body SOIC (2.5 kV) isolators used in the EVB and must NOT be used for 5 kV isolation testing.

3. Required Equipment

- Two dc power supplies (isolated)
- Two red and black banana-to-banana cables
- One straight-through RS232 cable (3'3, 2'2) (e.g., StarTech Model#MXT100_25)
- One crossover (null modem) RS232 cable (3'2, 2'3) (Ex. StarTech Model # SCNM9FM)
- One PC with COM1 port
- Si84xxCOM evaluation board (board under test)
- Si84xxCOM user's guide (this document)

3.1. Optional Equipment (User Can Test the Functionality of Standalone EVB Using the Following Equipment)

- One 4-channel oscilloscope, 250 MHz BW (e.g., TDS784A)
- Dual output Pattern/Function generator, 80 MHz data rate (e.g., Agilent 81104A)
- Two BNC to hook cable (e.g., Pomona #3788)

4. Hardware Overview and Demo

The Si84xxCOM evaluation board operates from 4.75 to 5.25 V. Each isolated interface is enabled or disabled by jumper option settings as shown in Figures 3, 4, and 5 (RS232, RS422/485 and CAN Bus isolated interfaces, respectively).

Refer to Figure 3:

- J3,J5 Connector for +5 V bus (J3) and GND(J5) plane
- J9,J6 Connector for +5VISO bus (J9) and ISOGND(J6) plane
- J15,J16 Header 2x1, Supply for RS232 interface
- J1,J2 DB9 Female (J1) and Male (J2) connector for RS232
- J4,J7,J8,J10 Header 2x1, RS232 loopback test enable

Refer to Figure 4:

- J17, J18 Header 2x1, Supply for RS422/485 interface
- J11,J12 DB9 Female (J1) and Male (J2) connector for RS422/485
- RJ1,RJ2 RJ45 connector for RS422/485

Refer to Figure 5:

- J19,J20 Header 2x1, Supply for CAN Bus interface
- J13,J14 DB9 Female (J13) and Male (J14) connector for CAN bus

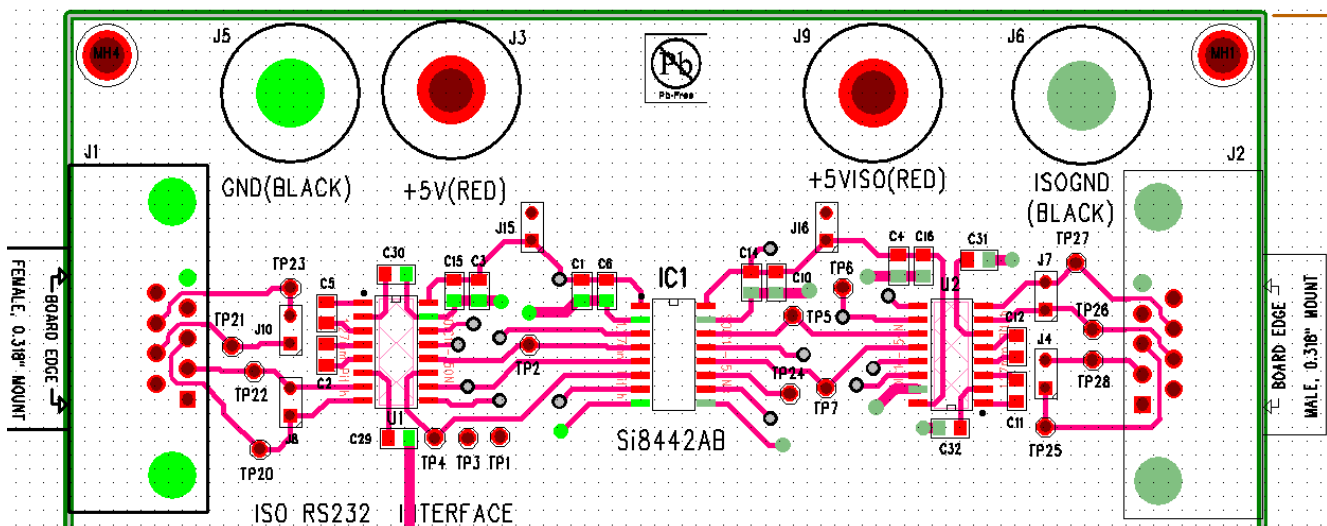

Figure 3. Power Supply Input and Isolated RS232 Interface

Si84xxCOM-EVB

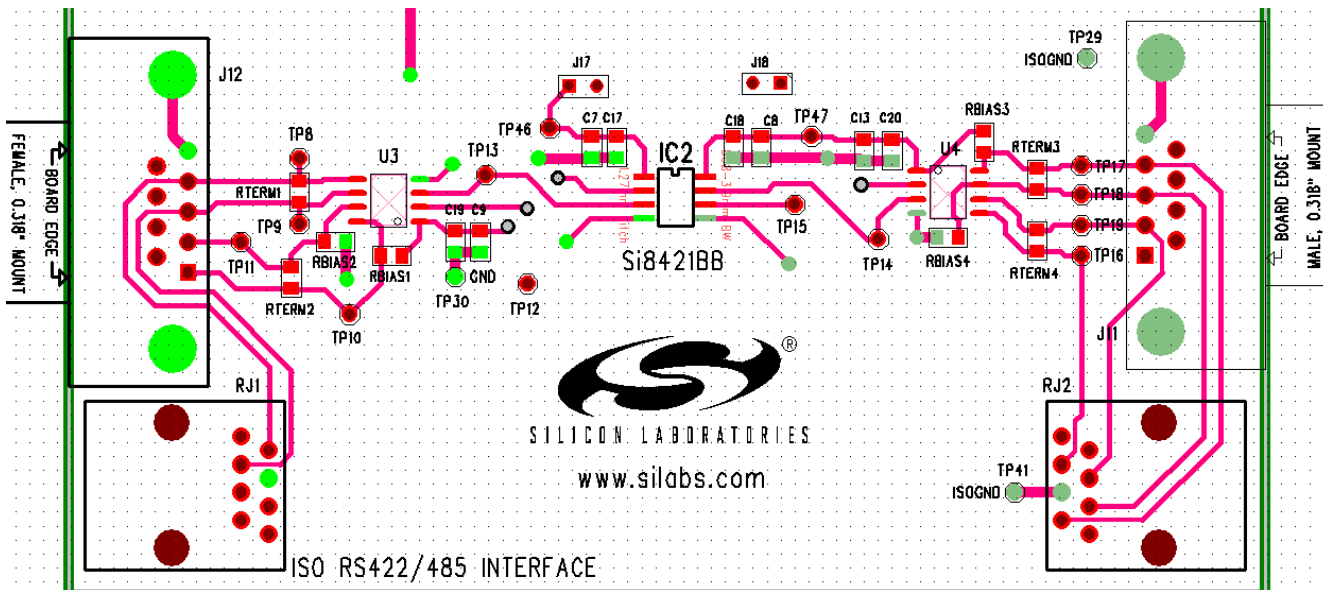

Figure 4. Isolated 4-Wire R422/485 Interface

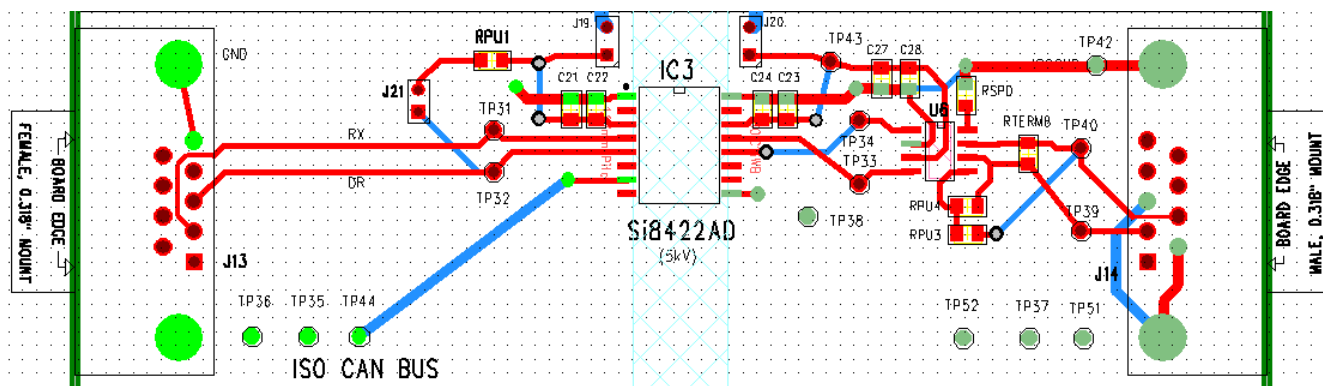

Figure 5. Isolated CAN Bus Interface

4.1. Common Board Setup

Perform the following steps for a common board setup:

1. Turn on the dc power supplies, and set the output voltage to 5.0 V, 500 mA current limit.
2. Connect red banana cables to each of the positive outputs of the power supply, and connect the black banana cables to the respective negative or 0 V output.
3. Turn off the dc power supply.
4. Connect the other end of one of the red banana cables to J3 (+5 V) and the other end of the second red banana cable to J9 (+5VISO).
5. Connect the other end of the black banana cable to J5 (GND) and J6 (ISOGND), respectively.

This completes the power supply connections to the board.

4.2. Isolated RS232 interface Setup

Perform the following steps for an isolated RS232 interface setup:

1. Power up a PC with the COM1 port (Male DB9 connector).
2. Connect one end of the straight-through RS232 cable to the COM1 port and the other end to J1 of the evaluation board. Table 1 lists the standard pin definitions of the interface.

Table 1. Isolated RS232 Pin Definitions

J1 DB9 (Female) Pinout	RS232 Signal Name	J2 DB9 (Male) Pinout
1,4,6,9	NC	1,4,6,9
2	RXD	2
3	TXD	3
5	GND	5
7	RTS	7
8	CTS	8

3. On the J2 side, use straight-through cable when connecting to DCE (Modem) and crossover cable when connecting to DTE (PC, printers, PLCs etc). Refer to Figures 6 and 7.
4. Shunt jumpers J15 and J16 to apply power to the circuit.
5. Turn ON the dc power supply.

The board under test is ready to transfer data.*

***Note:** Most PCs support data rates up to 115 kbps, but the onboard transceiver and isolator can support a maximum data rate of 1 Mbps.

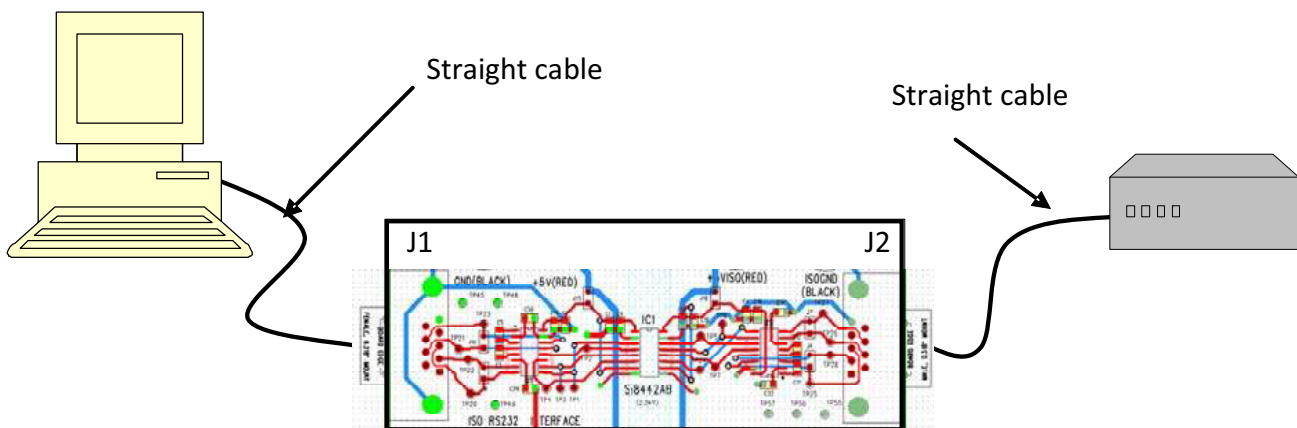

Figure 6. DTE to DCE Connection

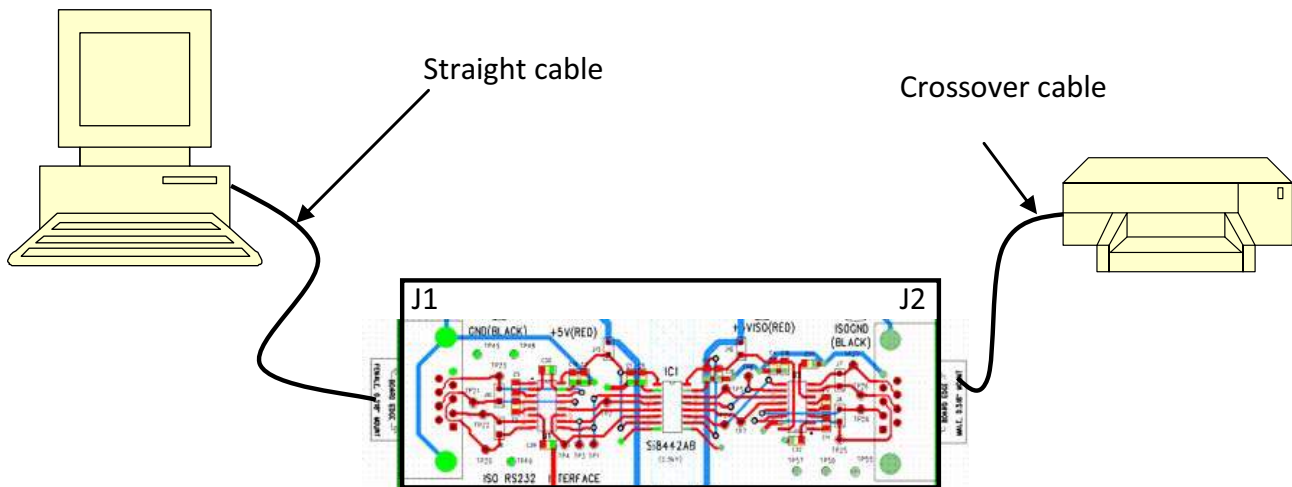

Figure 7. DTE to DTE Connection

4.3. Isolated RS422/485 Interface Setup

The RS422 and RS485 standards are based on a balanced differential line. The RS422 interface is typically implemented as a 4-wire, point-to-point communication system, whereas RS485 can be implemented in a 2-wire or 4-wire multipoint configuration.

Note: This EVB implements a full-duplex, isolated 4-wire RS422/RS485 interface with automatic flow control and should NOT be used to implement a 2-wire interface

Please note that the RS422/485 standard does not recommend a specific connector or pinout like the RS232 standard. In light of this, the EVB has DB9 and 8-pin-RJ45 connectors for flexibility, allowing the user to choose and follow the pinout definition table for proper cabling.

Proper termination is required at each end of the cable for reliable communication links and long wiring runs. The EVB has place holders (RTERM1-4) for termination resistors to match the characteristic impedance of the cable specified by the manufacturer. A typical value is around 120 Ω . The RS422/RS485 transceivers used in the EVB have 22 k Ω (~0.5 UL) receiver input resistance and a fail-safe feature that guarantees the receiver output HIGH when inputs are left open or shorted.

Perform the following steps for interface setup:

1. Turn off the dc power supplies (if they are not turned off already).
2. Shunt jumpers J17 and J18 to apply power to the circuit.
3. Refer to Table 2 for the RS422/485 connector pinout definition. Make sure the cable is made to this pinout definition.
4. Recommended cables are 24 AWG 2 twisted pair with shield (e.g., Belden 9842-500).
5. A simple 4-wire master slave point-to-point connection is shown in Figure 8 for reference.
 - Connect the transmitter output of the master node to the receiver input (J12.1 and J12.2) of the EVB board. Connect the transmitter output (J12.3 and J12.4) of the EVB to the receiver input of the master node.
 - Connect the isolated transmitter output (J11.1 and J11.2) of the EVB board to the receiver input of the slave node. Connect the transmitter output of the slave node to the isolated receiver input (J11.4 and J11.3) of the EVB.
6. Turn on the dc power supply.
7. The EVB is ready for data transfer and can support a maximum data rate of 52 Mbps.

Table 2. RS422/485 Pinout Definition for DB9 and RJ45 Connector

J12 (Female DB9) Pinout	RS422/485 Signal Name	J11 (Male DB9) Pinout	RS422/485 Signal Name
1	A (RxD+)	1	Y(TxD+)
2	B (RxD-)	2	Z(TxD-)
3	Z (TxD-)	3	B(RxD-)
4	Y (TxD+)	4	A(RxD+)
5	GND	5	GND
6,7,8,9	NC	6,7,8,9	NC

RJ1 Pinout	RS422/485 Signal Name	RJ2 Pinout	RS422/485 Signal Name
1,7,8	NC	1,7,8	NC
2	Y (TxD+)	2	A (RxD+)
3	Z (TxD-)	3	B(RxD-)
4	GND	4	GND
5	B (RxD-)	5	Z (TxD-)
6	A (RxD+)	6	Y (TxD+)

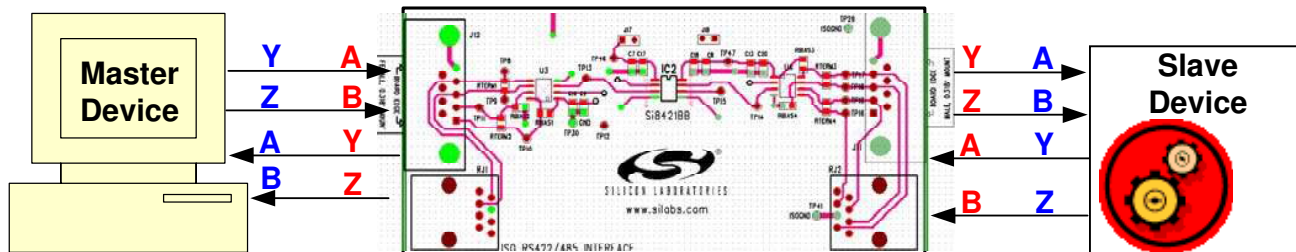

Figure 8. Simple Point-to-Point RS422/485 Connection

Si84xxCOM-EVB

4.4. Isolated CAN Bus Interface Setup

CAN (Controller Area Network) Bus is a bidirectional, 2-wire (CANH and CANL) differential signaling bus with a data rate up to 1 Mbps. The CAN bus signal has two states: recessive (logic High) and dominant (logic Low). When no driver is active, the bus is in the recessive state (CANH=CANL). The non-bus side of the transceiver is connected to a controller. The EVB implements an isolated controller-side CAN interface as shown in Figure 1. The speed/slope control resistor RSPD is tied to GND for high-speed (1 Mbps) operation. Users can increase the value of resistor RSPD for slower operation.

The CAN bus must be properly terminated at each end of the cable. The EVB comes with a standard termination of 120 Ω (RTERM8) installed. The Si8422AD digital isolator powers up with default high output making sure the CAN bus is in a recessive state.

Perform the following steps for interface setup:

1. Turn the power supply off, if it is not off already.
2. Shunt jumpers J19 and J20 to apply power to the circuit.
3. Standard twisted pair (24 AWG, ex HYCANBUS0901) with or without shield can be used. Refer to Table 3 for pinout definition. Make sure the cable is made to this pinout definition.
4. A typical connection to the EVB is shown in Figure 9.
 - Connect the controller side driver output and receiver input to the J13.3 (DR) and J13.2 (RX) pins of EVB respectively.
 - Connect the CANH (J14.7) and CANL (J14.2) of the EVB to the bus lines.
5. Turn on the dc power supply.

The EVB is ready for data transfer and can support a maximum data rate of 1 Mbps.

Table 3. CAN Bus Interface Pinout Definition

J13 (Female DB9) Pinout	CAN Bus Signal Name	J14 (Male DB9) Pinout	CAN Bus Signal Name
1,4,6,7,8,9	NC	1,4,5,6,8,9	NC
2	RX (Receiver Output)	2	CANL
3	DR (Driver Input)	3,6	GND
5	GND	7	CANH

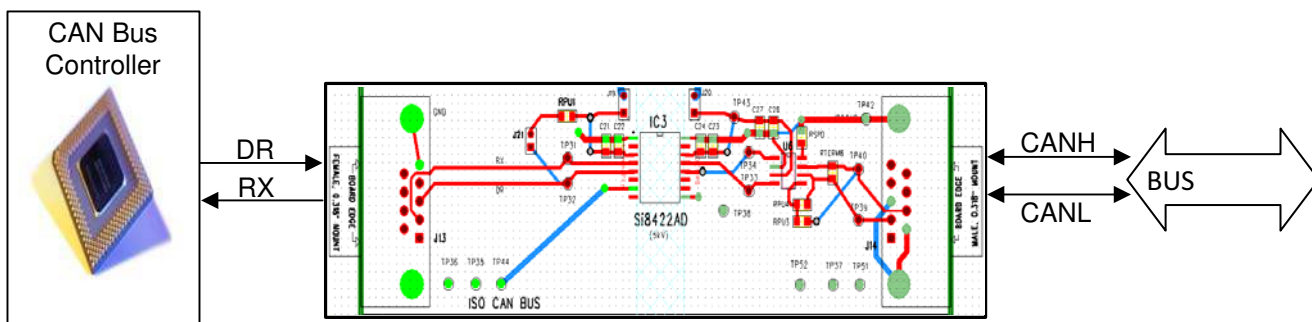

Figure 9. Isolated CAN Bus Interface Connection

5. Waveforms (tpdelay = Propagation Delay)

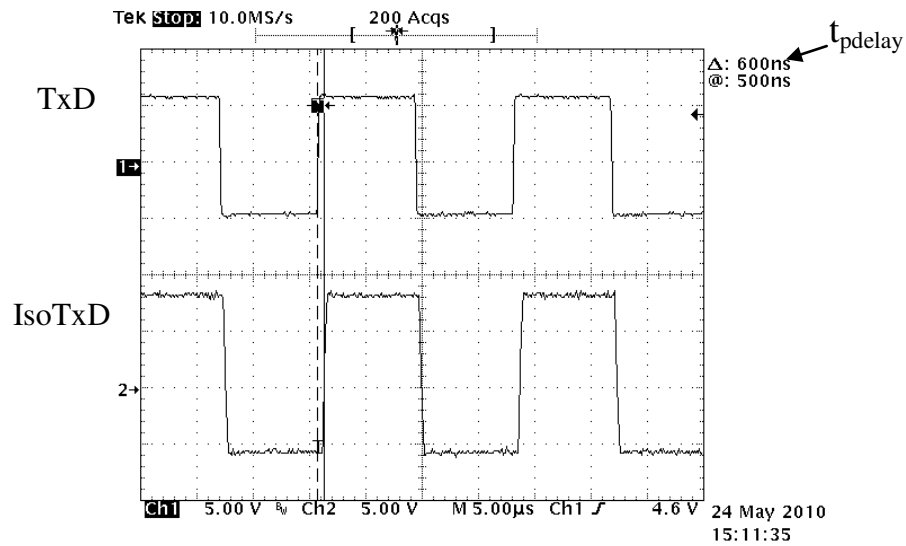

Figure 10. Isolated RS232 Signal at 115 kbps

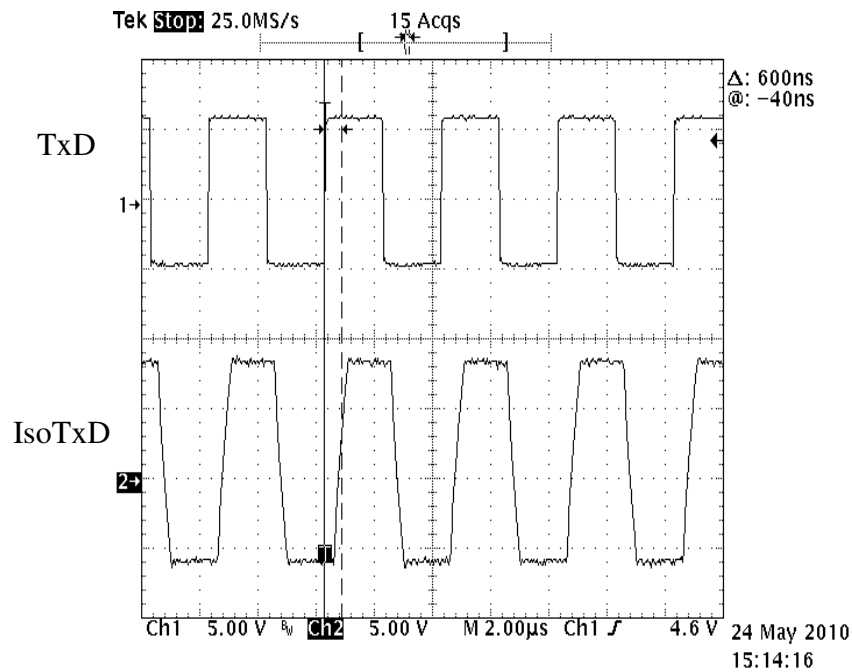

Figure 11. Isolated RS232 Signal at 500 kbps

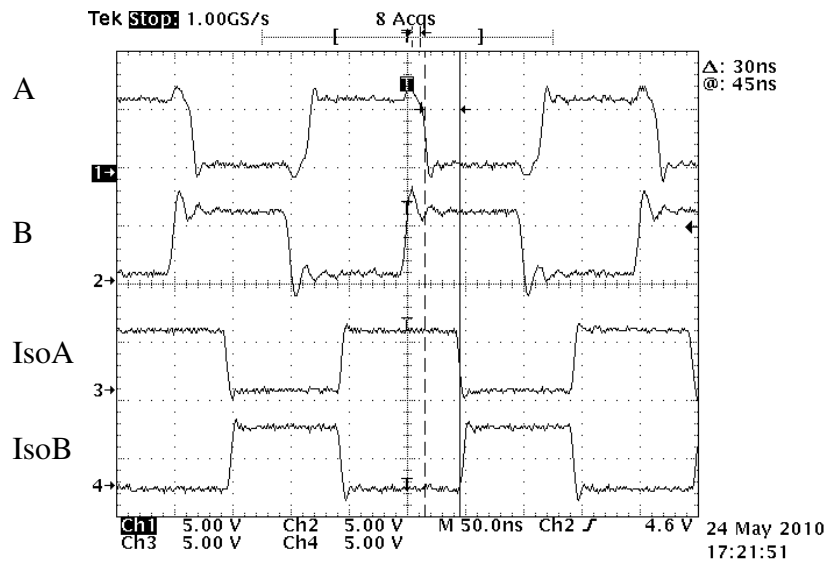

Figure 12. Isolated RS422/485 Signals (Unterminated) at 10 Mbps

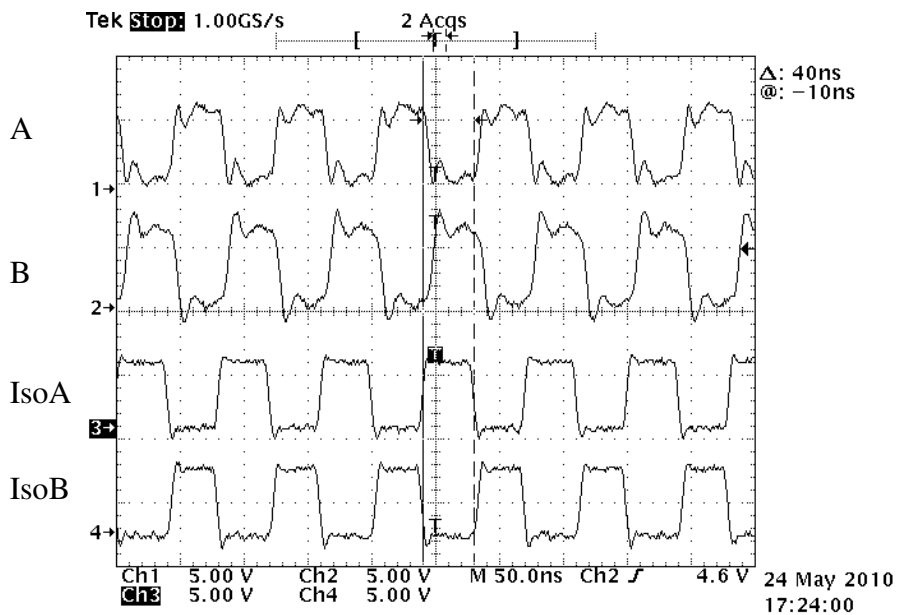

Figure 13. Isolated RS422/485 Signals (Unterminated) at 25 Mbps

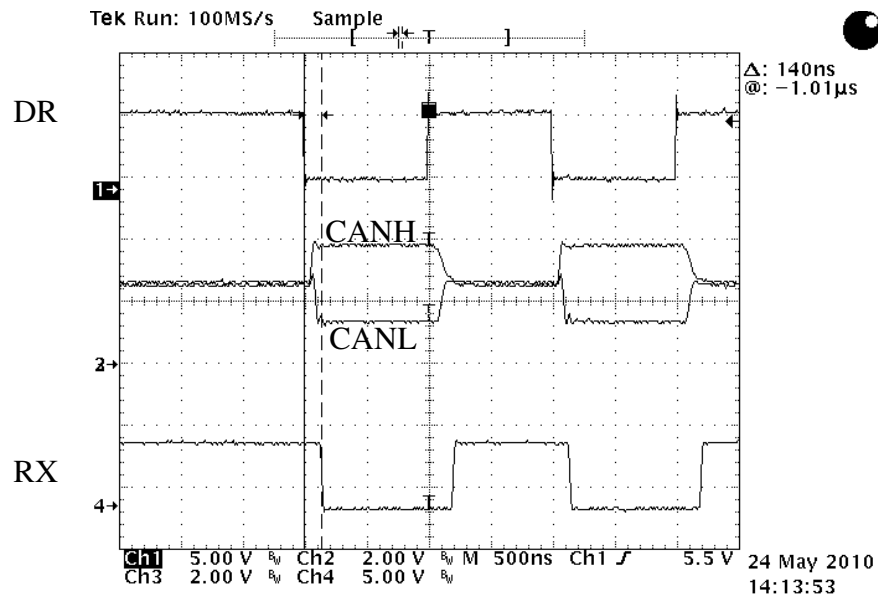

Figure 14. Isolated CAN Bus Signals (Terminated) at 1 Mbps

6. Schematics

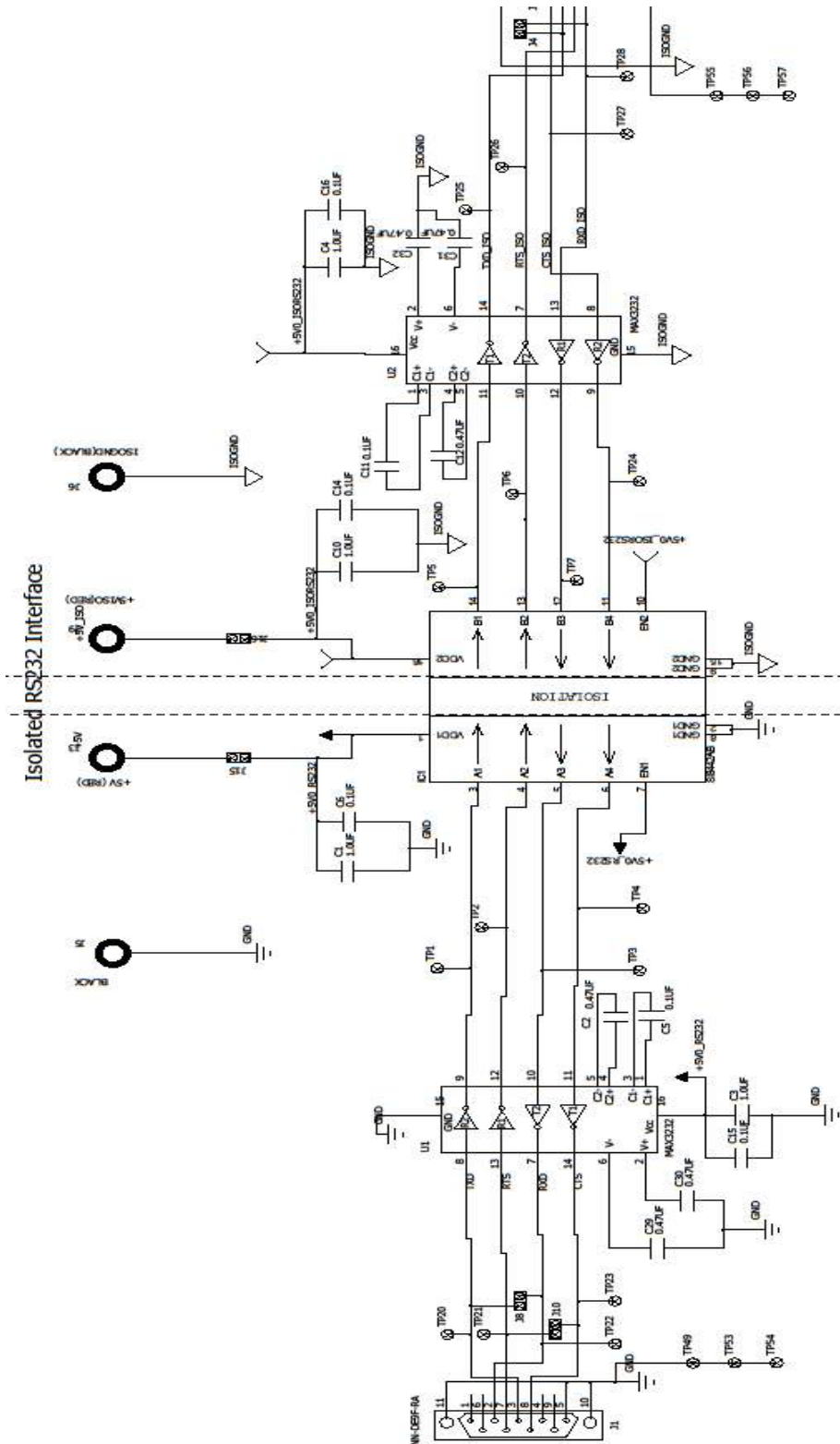

Figure 15. Isolated RS232 Interface Schematic

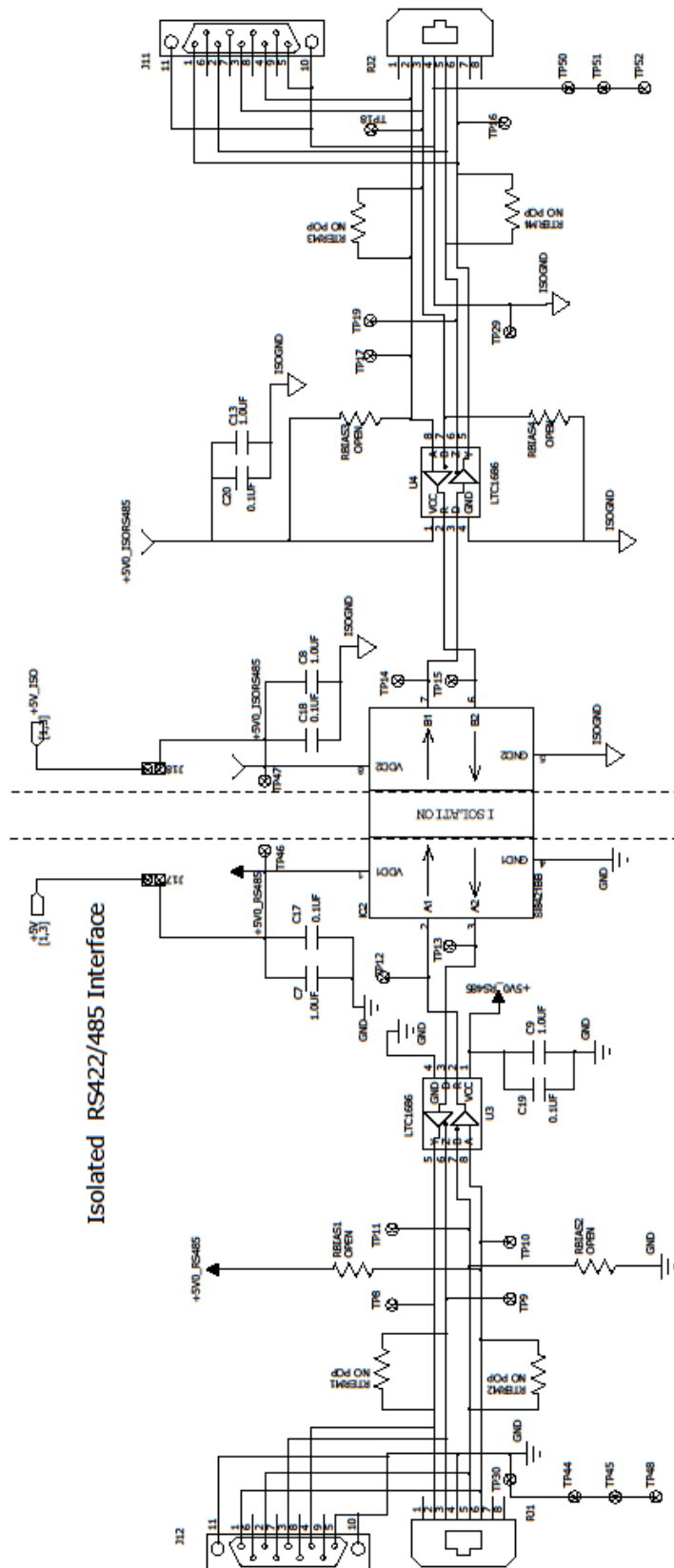

Figure 16. Isolated RS422/485 Interface Schematic

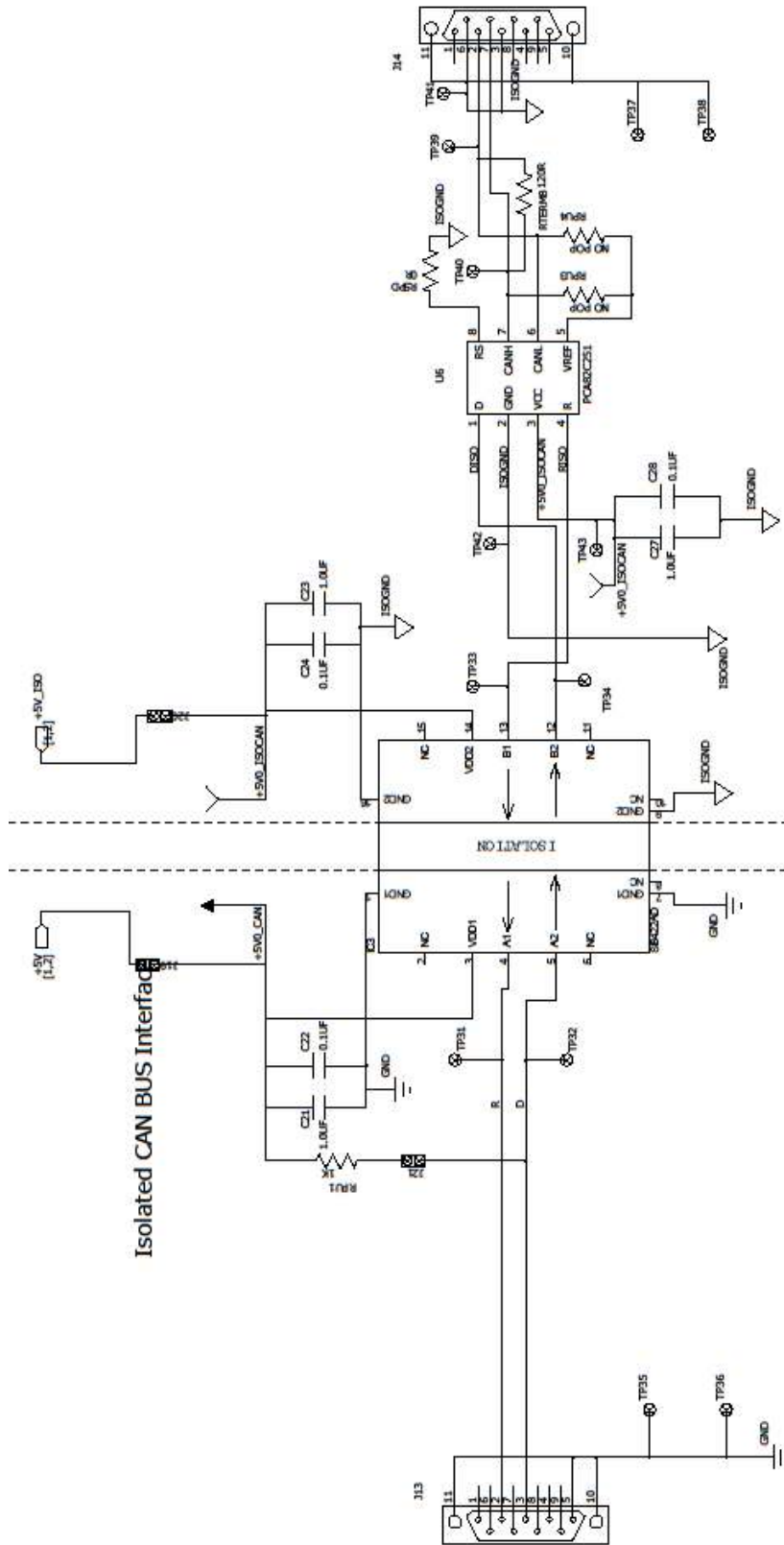

Figure 17. Isolated CAN bus Interface Schematic

7. Si84xxCOM Bill Of Materials

Item	Qty	Reference	Part Number	Manufacturer	Description
1	1	J3	111-0702-001-ND	DIGIKEY	RED BANANA-JACK, RoHS.
2	1	J9	111-0702-001-ND	DIGIKEY	RED BANANA-JACK, RoHS
3	1	J5	111-0703-001-ND	DIGIKEY	BLACK BANANA-JACK, RoHS
4	1	J6	111-0703-001-ND	DIGIKEY	BLACK BANANA-JACK, RoHS
5	2	C5 C11	C0805F104K4RACTU-ND	DIGIKEY	CAP,0.1UF,X7R, 0805,16V,10% OR EQ, RoHS
6	11	C6 C14-20	C0805F104K4RACTU-ND	DIGIKEY	CAP,0.1UF,X7R, 0805,16V,10% OR EQ, RoHS
		C22 C24			
		C28			
7	2	C2 C12	445-1357-1-ND	DIGIKEY	CAP,0.47UF,X7R, 0805,16V,10% OR EQ, RoHS
8	4	C29-32	445-1357-1-ND	DIGIKEY	CAP,0.47UF,X7R, 0805,16V,10% OR EQ, RoHS
9	11	C1 C3-4	PCC2314CT-ND	Digikey	CAP 1.0UF, X5R, CERAMIC, 0805, 16V, 10%, OR EQ, RoHS.
		C7-10 C13			
		C21 C23			
		C27			
10	3	J1 J12-13	A35109-ND	DIGIKEY	CONN, D-SUB PLUG, FEMALE, R/A, ANGLE, 9POS, 0.318MNT, RoHS.
11	3	J2 J11	A32092-ND	DIGIKEY	CONN, D-SUB PLUG, MALE, R/A, ANGLE, 9POS, 0.318MNT, RoHS.
		J14			
12	2	RJ1-2	A31442-ND	DIGIKEY	CONN, ETHERNET, RJ45-8 RIGHT ANGLE, OR EQ, RoHS.
13	11	J4 J7-8	S1011E-02-ND	DIGIKEY	STAKE HEADER, 1X2, 0.1"CTR, GOLD, OR EQ, RoHS..
		J10			
		J15-21			
14	2	U3-4	LTC1686CS8#PBF-ND	Linear Technology	5V RS422/485 TxRx, 52Mbps, SOIC8NB, RoHS
15	1	U6	PCA82C251T/N3	PHILIPS	IC, 5V, 1Mbps CAN TXRX, 8-SOIC, RoHS.
16	2	U1-2	MAX3232CSE+-ND	MAXIM	5V RS-232t TxRx, 1Mbps, SOIC16NB, RoHS
17	4	MH1-4	1902EK-ND/H546	DIGIKEY	STAND OFF WITH SCREW, RoHS.
18	1	RSPD	P0.0ATR-ND	DIGIKEY	RES, 0 OHM, SMT, 0805, 1/8W, 71%, OR EQ, RoHS.
19	1	RTERM8	RHM120AECT-ND	DIGIKEY	RES, 120 OHM, SMT, 0805, 1/4W, 71%, OR EQ, RoHS.
20	1	RPU1	P1.0KADTR-ND	DIGIKEY	RES, 1.0K OHM, SMT, 0805, 1/4W, 75%, OR EQ, RoHS.
21	2	RPU3-4	311-22KARTR-ND	DIGIKEY	RES, 22K OHM, SMT, 0805, 1/8W, 75%, OR EQ, RoHS.
22	4	RTERM1-4	NO POP	DIGIKEY	RES, NO POP OHM, SMT, 0805, 1/4W, 71%, OR EQ, RoHS.
23	1	RBIAS1	NO POP	DIGIKEY	RES, NO POP, SMT, 0805, 1/8W, 75%, OR EQ, RoHS.
24	1	RBIAS2	NO POP	DIGIKEY	RES, NO POP, 0805, 1/4W, 71%, OR EQ, RoHS.
25	2	RBIAS3-4	NO POP	DIGIKEY	RES, NO POP, SMT, 0805, 1/4W, 71%, OR EQ, RoHS.
26	1	IC2	Si8421BB-D-IS	Silicon Labs	2 Channel 2.5KV Digital Isolator, 150Mbps, SOIC8NB, RoHS
27	1	IC1	Si8442AB-D-IS1	Silicon Labs	4 Channel 2.5KV Digital Isolator, 1Mbps, SOIC16NB, RoHS
28	1	IC3	Si8422AD-B-IS	Silicon Labs	2 Channel 5KV Digital Isolator, Default High Output 1Mbps, SOIC16WB, RoHS
29	35	TP8-11	5000K-ND	DIGIKEY	Test point
		TP16-23			
		TP25-28			
		TP30			
		TP35-40			
		TP44-45			
		TP48-57			
30	22	TP1-7	NO POP		
		TP12-15			
		TP24 TP29			
		TP31-34			
		TP41-43			

8. Ordering Guide

Table 4. Ordering Guide

Ordering Part Number	Description
Si84xxCOM-RD	Isolated serial communication evaluation board

NOTES:

CONTACT INFORMATION

Silicon Laboratories Inc.
400 West Cesar Chavez
Austin, TX 78701
Tel: 1+(512) 416-8500
Fax: 1+(512) 416-9669
Toll Free: 1+(877) 444-3032

Please visit the Silicon Labs Technical Support web page:
<https://www.silabs.com/support/pages/contacttechnicalsupport.aspx>
and register to submit a technical support request.

The information in this document is believed to be accurate in all respects at the time of publication but is subject to change without notice. Silicon Laboratories assumes no responsibility for errors and omissions, and disclaims responsibility for any consequences resulting from the use of information included herein. Additionally, Silicon Laboratories assumes no responsibility for the functioning of undescribed features or parameters. Silicon Laboratories reserves the right to make changes without further notice. Silicon Laboratories makes no warranty, representation or guarantee regarding the suitability of its products for any particular purpose, nor does Silicon Laboratories assume any liability arising out of the application or use of any product or circuit, and specifically disclaims any and all liability, including without limitation consequential or incidental damages. Silicon Laboratories products are not designed, intended, or authorized for use in applications intended to support or sustain life, or for any other application in which the failure of the Silicon Laboratories product could create a situation where personal injury or death may occur. Should Buyer purchase or use Silicon Laboratories products for any such unintended or unauthorized application, Buyer shall indemnify and hold Silicon Laboratories harmless against all claims and damages.

Silicon Laboratories and Silicon Labs are trademarks of Silicon Laboratories Inc.

Other products or brandnames mentioned herein are trademarks or registered trademarks of their respective holders.