

FEATURES

- 3.3V and 5V power supply option
- Up to 1.25Gbps operation
- Low noise
- Chatter-free LOS generation
- Open collector TTL LOS output
- TTL /EN Input
- Differential PECL inputs for data
- Single power supply
- Designed for use with laser diode driver and controller
- Available in a tiny 10-pin (3mm x 3mm) MSOP

APPLICATIONS

- 1.25Gbps Gigabit Ethernet
- 531Mbps and 1062Mbps Fibre Channel
- 622Mbps SONET
- Gigabit Interface Converter

BLOCK DIAGRAM

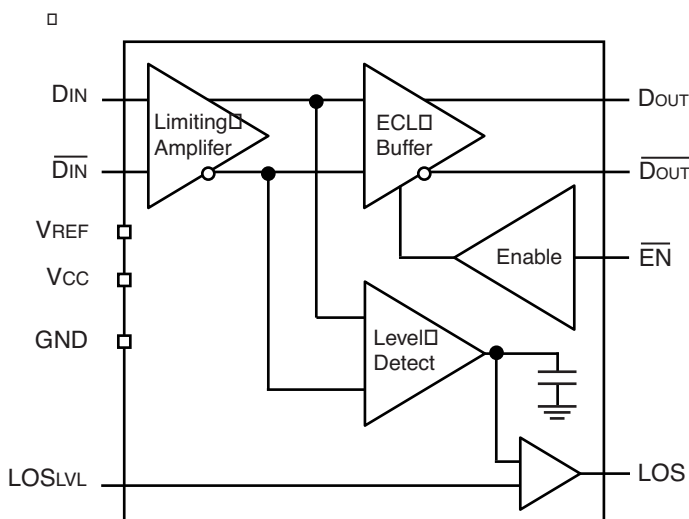

DESCRIPTION

The SY88903V limiting post amplifier with its high gain and wide bandwidth is ideal for use as a post amplifier in fiber optic receivers with data rates up to 1.25Gbps. Signals as small as $5mV_{pp}$ can be amplified to drive devices with PECL inputs. The SY88903V generates a chatter-free, Loss-of-Signal (LOS), open-collector TTL output.

The SY88903V is an integrated limiting amplifier intended for high-frequency fiber optic applications. The circuit connects to typical transimpedance amplifiers found within a fiber optics link. The linear signal output from a transimpedance amplifier can contain significant amounts of noise, and may vary in amplitude over time. The SY88903V limiting amplifier quantizes the signal and outputs a voltage-limited waveform.

The /EN pin allows the user to disable the output signal without removing the input signal.

The SY88903V incorporates a programmable level detect function to identify when the input signal has been lost. This information can be fed back to the /EN input of the device to maintain stability under loss of signal condition. The sensitivity of the level detection can be adjusted using LOS_{LVL} . The LOS_{LVL} voltage can be set by connecting a resistor divider between V_{CC} and V_{REF} as shown in Figure 3. "Typical Characteristics" show the relationship between input level sensitivity and the voltage set on LOS_{LVL} .

The LOS output is a TTL open-collector output that requires a pull-up resistor for proper operation, Figure 1.

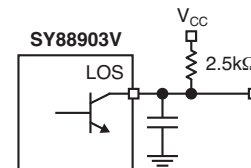
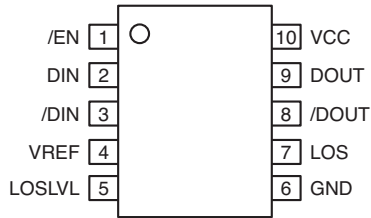

Figure 1. LOS Output with Desired Rise Time

All support documentation can be found on Micrel's web site at www.micrel.com.

PACKAGE/ORDERING INFORMATION



10-Pin MSOP (K10-1)

Ordering Information⁽¹⁾

Part Number	Package Type	Operating Range	Package Marking	Lead Finish
SY88903VKC	K10-1	Commercial	903V with Pb-free bar-line indicator	Sn-Pb
SY88903VKCTR ⁽²⁾	K10-1	Commercial	903V with Pb-free bar-line indicator	Sn-Pb
SY88903VKG	K10-1	Industrial	903V with Pb-free bar-line indicator	NiPdAu Pb-Free
SY88903VKGTR ⁽²⁾	K10-1	Industrial	903V with Pb-free bar-line indicator	NiPdAu Pb-Free

Notes:

1. Contact factory for die availability. Die is guaranteed at T_A = 25°C, DC electricals only.
2. Tape and Reel.

PIN DESCRIPTION

Pin Number	Pin Name	Type	Pin Function
1	EN	TTL Input	Output Enable (Active Low).
2	DIN	Data Input	Data Input.
3	/DIN	Data Input	Inverting Data Input.
4	VREF	Output	Reference Voltage Output for LOS Level Set (see Figure 3).
5	LOSLVL	Input	LOS Limit Set.
6	GND	Ground	Ground
7	LOS	TTL Output (Open Collector)	Loss-of-Signal Indicator (Active Low).
8	/DOUT	PECL Output	Inverting Data Output.
9	DOUT	PECL Output	Data Output.
10	VCC	Power Supply	Positive Power Supply.

Absolute Maximum Ratings⁽¹⁾

Supply Voltage (V_{CC}) 0V to +7.0V
 Input Voltage (D_{IN} , $/D_{IN}$, $/EN$, LOS_{LVL}) 0V to V_{CC}
 Output Voltage
 (D_{OUT} , $/D_{OUT}$) with 50 Ω Load ... $V_{CC} - 2.5V$ to $V_{CC} + 0.3V$
 (V_{REF}) $V_{CC} - 2.0V$ to V_{CC}
 Lead Temperature (soldering, 20 sec.) 260°C
 Maximum Operating Junction Temperature (T_J) +125°C
 Storage Temperature (T_S) -55°C to +125°C

Operating Ratings⁽²⁾

Supply Voltage (V_{IN}) +2.97V to +5.5V
 Ambient Temperature (T_A) -40°C to +85°C
 Package Thermal Resistance
 MSOP (θ_{JA}) Still-air 113°C/W

DC ELECTRICAL CHARACTERISTICS

$V_{CC} = +5V \pm 10\%$ or $+3.3V \pm 10\%$; $R_{LOAD} = 50\Omega$ to $V_{CC} - 2V$; $T_A = -40^\circ C$ to $+85^\circ C$; unless noted.

Symbol	Parameter	Condition	Min	Typ	Max	Units
I_{CC}	Power Supply Current	No output load		30	42	mA
I_{IL}	$/EN$ Input LOW Current	$V_{IN} = 0.5V$	-0.3			mA
I_{IH}	$/EN$ Input HIGH Current	$V_{IN} = 2.7V$ $V_{IN} = V_{CC}$			20 100	μA
V_{CMR}	Common Mode Range		GND +2.0		V_{CC}	V
V_{OFFSET}	Differential Output Offset				± 160	mV
LOS_{LVL}	LOS_{LVL} Level		V_{REF}		V_{CC}	V
V_{OL}	LOS Output Low Level	$I_{OL} = +2mA$			0.5	V
I_{OH}	LOS Output Leakage	$V_{OH} = 5.5V$			250	μA
V_{OH}	$DOUT$ and $/DOUT$ HIGH Output		$V_{CC} - 1085$	$V_{CC} - 955$	$V_{CC} - 880$	mV
V_{OL}	$DOUT$ and $/DOUT$ LOW Output		$V_{CC} - 1830$	$V_{CC} - 1705$	$V_{CC} - 1620$	mV
V_{REF}	Reference Supply		$V_{CC} - 1.38$	$V_{CC} - 1.32$	$V_{CC} - 1.26$	V
I_{REF}	V_{REF} Output Current		-0.8		0.5	mA
V_{IH}	$/EN$ Input HIGH Voltage		2.0			V
V_{IL}	$/EN$ Input LOW Voltage				0.8	V

Notes:

1. Permanent device damage may occur if absolute maximum ratings are exceeded. This is a stress rating only and functional operation is not implied at conditions other than those detailed in the operational sections of this data sheet. Exposure to absolute maximum ratings conditions for extended periods may affect device reliability.
2. The data sheet limits are not guaranteed if the device is operated beyond the operating ratings.

AC ELECTRICAL CHARACTERISTICS

$V_{CC} = +5V \pm 10\%$ or $+3.3V \pm 10\%$; $R_{LOAD} = 50\Omega$ to $V_{CC} - 2V$; $T_A = -40^\circ C$ to $+85^\circ C$; unless noted.

Symbol	Parameter	Condition	Min	Typ	Max	Units
PSRR	Power Supply ⁽³⁾ Rejection Ratio	Input referred, 55MHz		35		dB
V_{ID}	Input Voltage Range		5		1800	mV _{pp}
t_r, t_f	Output Rise/Fall Time	$V_{ID} > 100mV_{pp}$ $V_{ID} < 100mV_{pp}$		t_{rin}, t_{fin}	260	ps
V_{OD}	Differential Output Voltage Swing ⁽⁴⁾	$V_{ID} = 15mV_{pp}$ $V_{ID} = 5mV_{pp}$		600 200		mV mV
t_{OFFL}	LOS Release Time ⁽⁵⁾ Minimum Input			0.1	0.5	μs
t_{OFFH}	LOS Release Time ⁽⁶⁾ Maximum Input			0.1	0.5	μs
t_{ONL}	LOS Assert Time ⁽⁵⁾			0.2	0.5	μs
VSR	LOS Sensitivity Range	$2^{23}-1$ pattern	5		50	mV _{pp}
HYS	LOS Hysteresis	$2^{23}-1$ pattern	2	4.6	8	dB

Notes:

3. Input referred noise = RMS output noise/low frequency gain.
4. Input is a 622MHz square wave.
5. Input is a 200MHz square wave, $t_r < 300ps$, $8mV_{pp}$.
6. Input is a 200MHz square wave, $t_r < 300ps$, $1.8V_{pp}$.

TYPICAL CHARACTERISTICS

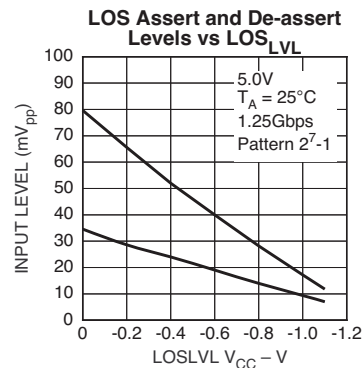
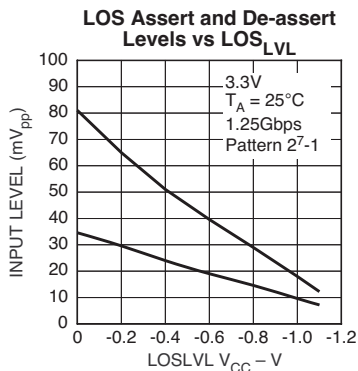

DESIGN PROCEDURE

Output Termination

The SY88903V outputs must be terminated with a 50Ω load to V_{CC} -2V (or Thevenin equivalent).

Layout and PCB Design

Since the SY88903V is a high-frequency component, performance can largely be determined by board layout and design. A common problem with high-gain amplifiers is feedback from the large swing outputs to the input via the power supply.

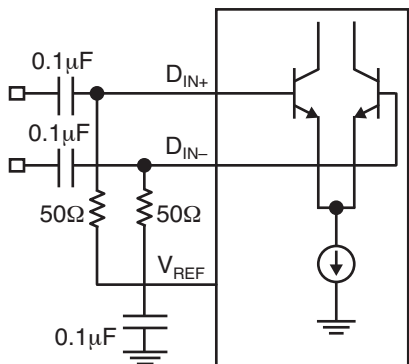
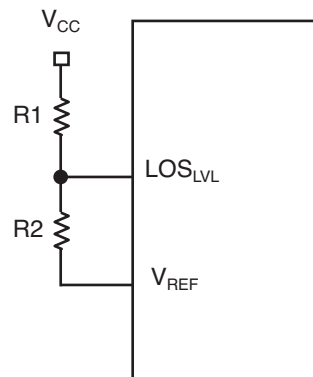

Figure 2. Differential Input Configuration

The SY88903V ground pin should be connected to the circuit board ground. Use multiple PCB vias close to the part to connect to ground. Avoid long, inductive runs which can degrade performance.



Notes:
 $LOSLVs = V_{CC} - 1.32V \times \frac{R1}{R1 + R2}$
 $R1 + R2 \geq 2.6k\Omega$

Figure 3. LOSLVL Circuit

10-PIN MSOP (K10-1)

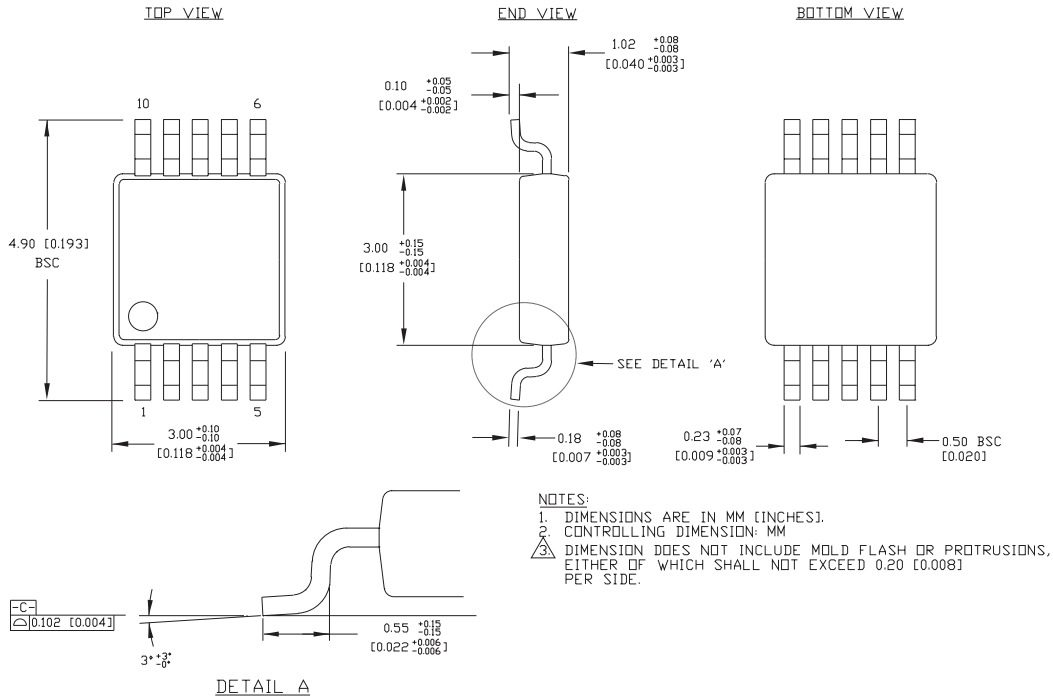

Rev. 00

MICREL, INC. 2180 FORTUNE DRIVE SAN JOSE, CA 95131 USA

TEL + 1 (408) 944-0800 FAX + 1 (408) 474-1000 WEB <http://www.micrel.com>

The information furnished by Micrel in this data sheet is believed to be accurate and reliable. However, no responsibility is assumed by Micrel for its use. Micrel reserves the right to change circuitry and specifications at any time without notification to the customer.

Micrel Products are not designed or authorized for use as components in life support appliances, devices or systems where malfunction of a product can reasonably be expected to result in personal injury. Life support devices or systems are devices or systems that (a) are intended for surgical implant into the body or (b) support or sustain life, and whose failure to perform can be reasonably expected to result in a significant injury to the user. A Purchaser's use or sale of Micrel Products for use in life support appliances, devices or systems is at Purchaser's own risk and Purchaser agrees to fully indemnify Micrel for any damages resulting from such use or sale.

© 2006 Micrel, Incorporated.