

SUGGESTED REAR PANEL MOUNTING CUTOUT DIMENSIONS SCALE 2:1

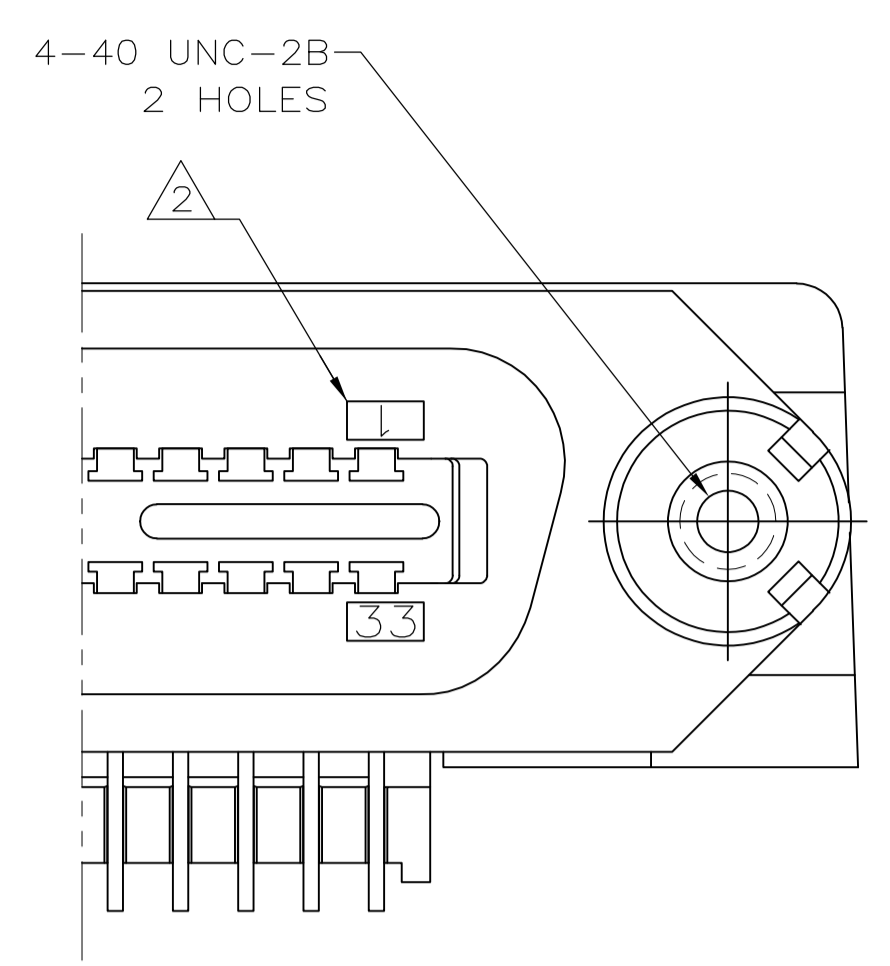

DETAIL A STANDARD ORIENTATION

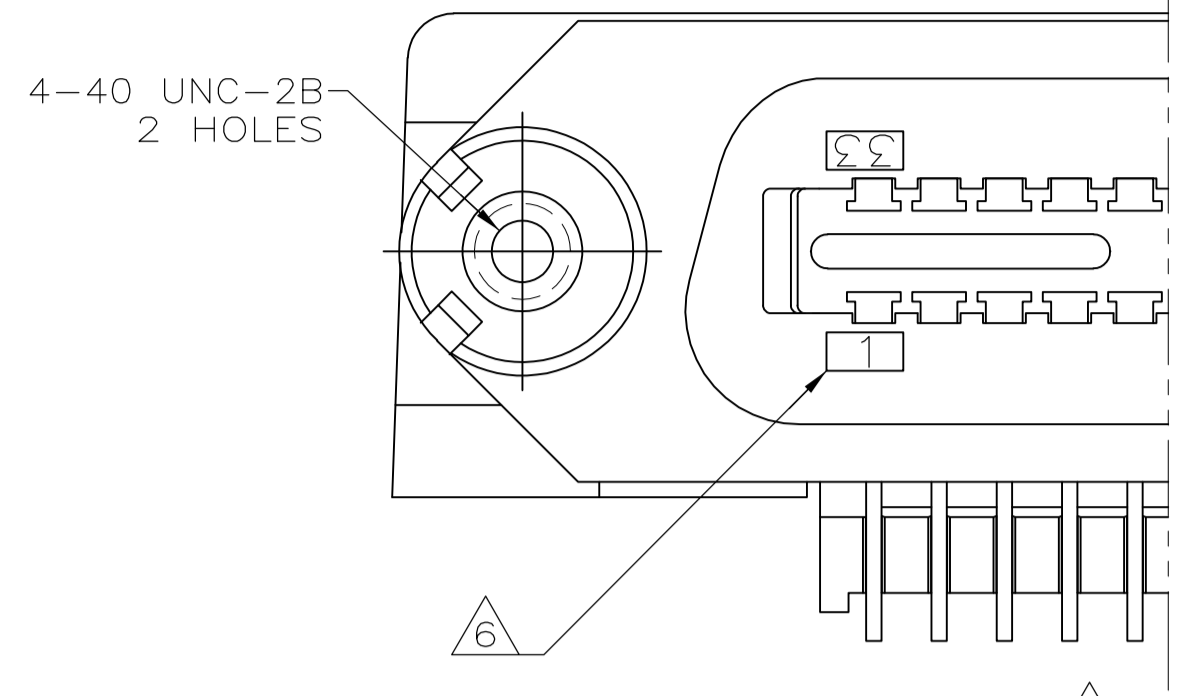

DETAIL B REVERSE ORIENTATION

- △ MATERIAL: HOUSING, BRACKET, PLATE AND COMB - THERMOPLASTIC, BLACK, 94V-0 RATED. TERMINALS - HIGH STRENGTH COPPER ALLOY PLATED WITH EITHER 0.76µm [.000030] MIN GOLD PLATE OR GOLD FLASH OVER PALLADIUM NICKEL PLATE, 0.76µm [.000030] MIN TIN ON MATING SURFACE. 3.05µm [.000120] MIN TIN PLATE ON TAILS. ALL OVER 1.27µm [.000050] MIN NICKEL UNDERPLATE OVER ENTIRE TERMINAL. THREADED INSERT - #4-40 UNC, BRIGHT ZINC PLATED BRASS.
- △ TERMINAL 1 IS LOCATED IN THIS ROW FOR STANDARD ORIENTATION, 5552744-1, AND -5.
- △ MAXIMUM DIMENSION FOR REAR PANEL MOUNTING.
- △ TERMINAL SUPPORT PLATE CLEARANCE FOR TERMINAL STRAIN RELIEF AND FLUX REMOVAL.
- △ MAXIMUM PANEL THICKNESS: 1.57[.062].
- △ TERMINAL 1 IS LOCATED IN THIS ROW FOR REVERSE ORIENTATION, 5552744-2, AND -6 ONLY.
- △ DETAILS "A" AND "B" ARE VIEWED FROM MATING SIDE OF RECEPTACLE ASSEMBLY.
- △ FOR USE WITH A NO.4 BT TYPE SELF-TAPPING SCREW.
- △ 5552744-1, -2, -5 & -6 ARE TAPPED 4-40; -7 AND -8 USE 4-40 THREADED INSERTS.
- △ INSERT SHALL WITHSTAND 8 INCH-POUNDS OF TORQUE WITHOUT CRACKING HOUSING OR LOOSENING.

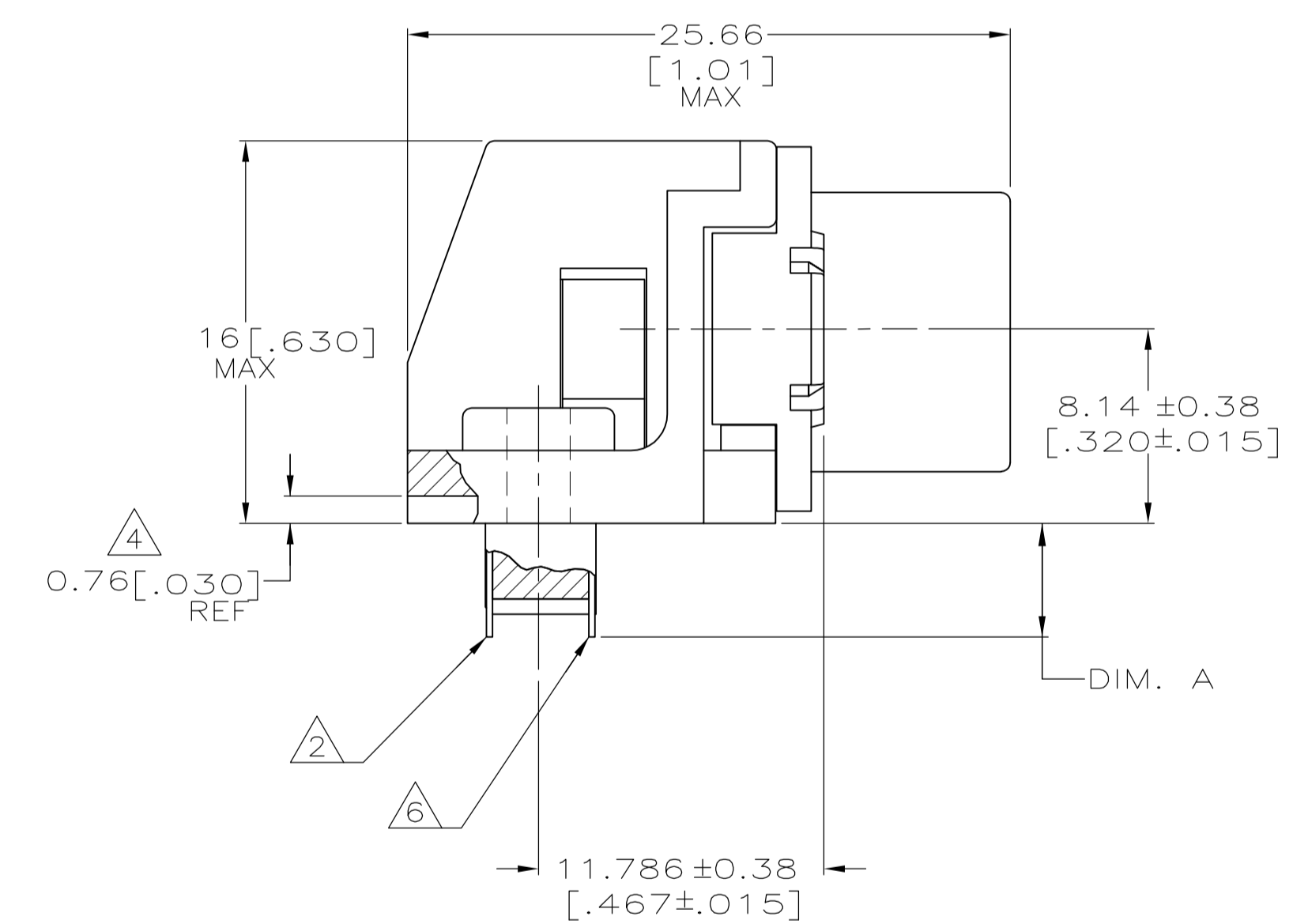
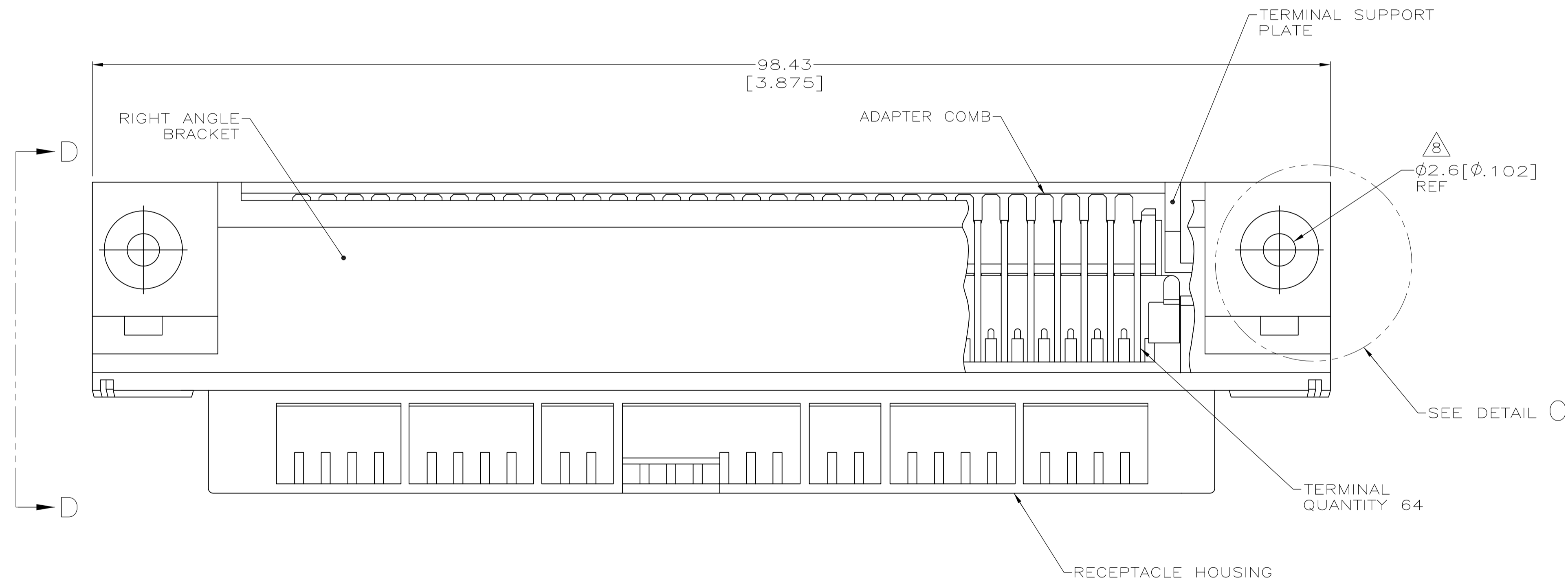

VIEW D-D ROTATED 90° CCW

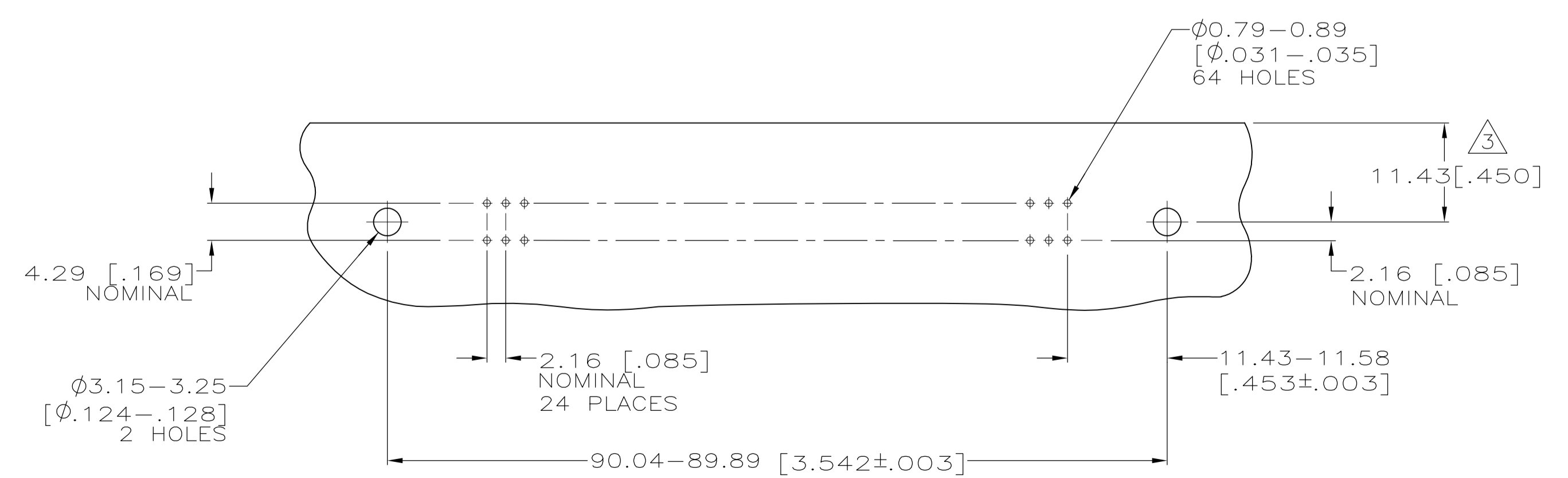

SUGGESTED PRINTED CIRCUIT BOARD MOUNTING DIMENSIONS SCALE 2:1

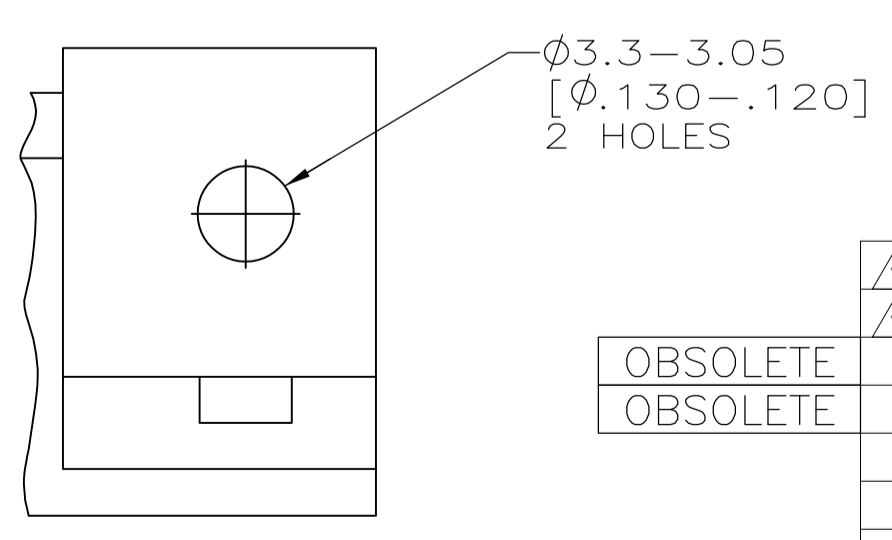

DETAIL C (THRU-BOLT)

9	10	THREADED INSERT	2.54±0.38[.100±.015]	8	SELF-TAPPING	SEE DETAIL B	5552744-8
9	10	THREADED INSERT	2.54±0.38[.100±.015]	8	SELF-TAPPING	SEE DETAIL A	5552744-7
OBSOLETE		TAPPED HOLE	2.54±0.38[.100±.015]	8	SELF-TAPPING	SEE DETAIL B	5552744-6
OBSOLETE		TAPPED HOLE	2.54±0.38[.100±.015]	8	SELF-TAPPING	SEE DETAIL A	5552744-5
		TAPPED HOLE	4.75±0.38[.187±.015]	6	SELF-TAPPING	SEE DETAIL B	5552744-2
		TAPPED HOLE	4.75±0.38[.187±.015]	8	SELF-TAPPING	SEE DETAIL A	5552744-1
		THREAD TYPE	DIM. A		TYPE OF MOUNTING	DESCRIPTION	PART NUMBER

THIS DRAWING IS A CONTROLLED DOCUMENT.		DIN B MCMASTER 27JULY05	Tyco Electronics Corporation Harrisburg, Pa 17105-3608	
DIMENSIONS: mm [INCHES]	TOLERANCES UNLESS OTHERWISE SPECIFIED:	CHK W MILLHIMES 27JULY05	NAME	RECEPTACLE ASSEMBLY, 64 POSITION, RIGHT ANGLE, PCB, THRU-BOLT/SELF TAPPING, CHAMP-LOK
0 PLC ± -	1 PLC ± -	APVD W MILLHIMES 27JULY05	SIZE	A1
2 PLC ± -	3 PLC ± 0.13[.005]	APPLICATION SPEC	WEIGHT	000779
4 PLC ± -	ANGLES ± -	RESTRICTED TO	CUSTOMER DRAWING	SCALE 4:1 SHEET 1 OF 1 REV D