

Evaluation Board User Guide for the **LTC6228** Low Distortion, Rail-to-Rail Output Op Amps with Shutdown

FEATURES

- Enables efficient prototyping
- User defined circuit configuration
- Edge mounted SMA connector provisions
- Simple connection to test equipment and other circuits
- RoHS compliant

EVALUATION KIT CONTENTS

EVAL-LTC6228IS8 Evaluation Board

EQUIPMENT NEEDED

- Dual output dc power supply
- Signal generator
- Three banana plug to grabber cables
- Two SMA to BNC male cables

GENERAL DESCRIPTION

The EVAL-LTC6228IS8 allows the evaluation of the [LTC6228](#), 8-lead, single channel, small outline integrated circuit (SOIC-N), 150 mil operational amplifier (op amp). The EVAL-LTC6228IS8 is a prepopulated board on a buffer configuration with a post low-pass filter at a cutoff frequency of 80 MHz. This configuration allows the [LTC6228](#) to be used as a high speed analog-to-digital converter (ADC) driver. The EVAL-LTC6228IS8 supports other typical configurations of an op amp and has provisions for typical applications of the [LTC6228](#), which includes an active filter. The SHDN_N pin can be shunt with the VCC pin, the VEE pin, or to an external voltage drive.

The 4-layer EVAL-LTC6228IS8 accepts edge mounted Subminiature Version A (SMA) connectors on both inputs and outputs to provide an efficient connection to the test equipment and other circuitry. In addition, the EVAL-LTC6228IS8 has sufficient test points for signal pins and groundings.

Optimized power and ground planes ensure low noise and high speed operation. Component placement and power supply bypassing are optimized for maximum circuit flexibility and performance. The EVAL-LTC6228IS8 accepts C0402 or C0603

surface-mount technology (SMT) components and C1206 bypass capacitors for C8 and C9.

All components are placed on the primary side of the EVAL-LTC6228IS8, and no components are placed on the secondary side.

For full details on the [LTC6228](#), see the [LTC6228](#) data sheet, which must be consulted in conjunction with this user guide when using the EVAL-LTC6228IS8.

EVALUATION BOARD PHOTOGRAPHS

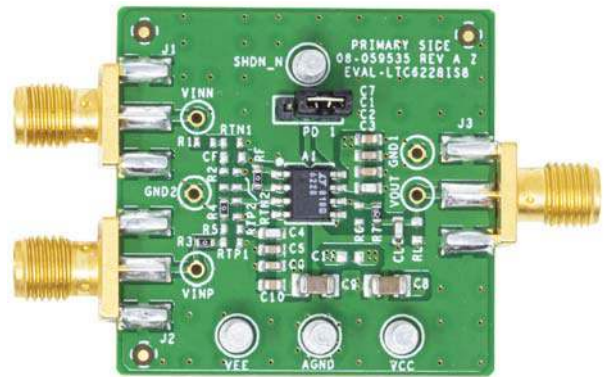

Figure 1. EVAL-LTC6228IS8, Primary Side

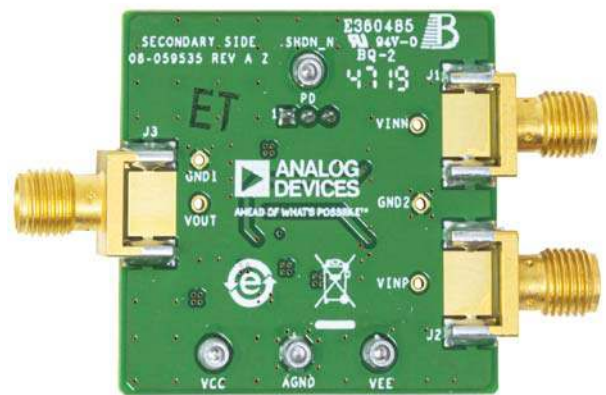

Figure 2. EVAL-LTC6228IS8, Secondary Side

TABLE OF CONTENTS

Features	1	Using the Evaluation Board for Testing	3
Evaluation Kit Contents.....	1	Evaluation Board Hardware.....	4
Equipment Needed.....	1	Power Supply Bypassing.....	4
General Description	1	Evaluation Board Stack Up	4
Evaluation Board Photographs	1	Evaluation Board Schematic and Artwork.....	5
Revision History	2	Ordering Information.....	7
Evaluation Board Quick Start Procedure	3	Bill of Materials.....	7
Power Supply Consideration.....	3		
Initial Board Configuration	3		

REVISION HISTORY

12/2019—Revision 0: Initial Version

EVALUATION BOARD QUICK START PROCEDURE

The following sections outline the basic prepopulated configuration of the EVAL-LTC6228IS8 required to test the basic functionality of the board.

POWER SUPPLY CONSIDERATION

Use the turret pins (VCC, VEE, and GND) to power up the EVAL-LTC6228IS8. Use the correct polarity and voltage level to avoid reverse polarity and overvoltage, which can permanently damage the EVAL-LTC6228IS8 (see the Using the Evaluation Board for Testing section for more information).

INITIAL BOARD CONFIGURATION

To test the basic functionality of the EVAL-LTC6228IS8 and the device, take the following steps:

1. Ensure that all equipment is powered down, including the power supply and the signal generator.
2. Use a banana plug to grabber cable to connect the positive supply, ground, and negative supply to the VCC, GND, and VEE turret pins, respectively.
3. Use an SMA to bayonet Neill-Concelman (BNC) connector to connect the on-board SMA connector test point (VINP) on the J2 connector to a signal generator channel.
4. Use an SMA to BNC connector to connect the on-board SMA connector test point (VOUT) on the J3 connector to an oscilloscope channel.

USING THE EVALUATION BOARD FOR TESTING

When the procedure in the Initial Board Configuration section is complete, implement the following settings and verify the expected output:

1. Set the power supply to 5 V for the positive supply, and -5 V for the negative supply.
2. Select the output waveform for both signal generator channels to be a sine wave with a frequency of 1 kHz, and a peak-to-peak voltage of 2 V.
3. Set the output load of the signal generator to be in a high-Z load.
4. Set the oscilloscope termination to 1 M Ω and observe the oscilloscope frequency and the peak-to-peak voltage.
5. When all equipment is set up, turn on the power supply and check the voltage and current consumption of the EVAL-LTC6228IS8. The expected current consumption is approximately 18 mA per channel of the device (36 mA for dual-channel), and the current drawn from the supply must not exceed 25 mA.
6. When turning the power supply on, turn on the signal generator.
7. Observe the output at the oscilloscope. The output of VOUT is a sine wave with a frequency of 1 kHz, and a peak-to-peak voltage of approximately 2 V.

EVALUATION BOARD HARDWARE

POWER SUPPLY BYPASSING

External bypass capacitors such as C8 and C9 are provided for low level frequency bypassing at the amplifier power pins. Additional capacitors (C1 to C7 and C10) are provided for additional higher level frequency bypassing (see Figure 3).

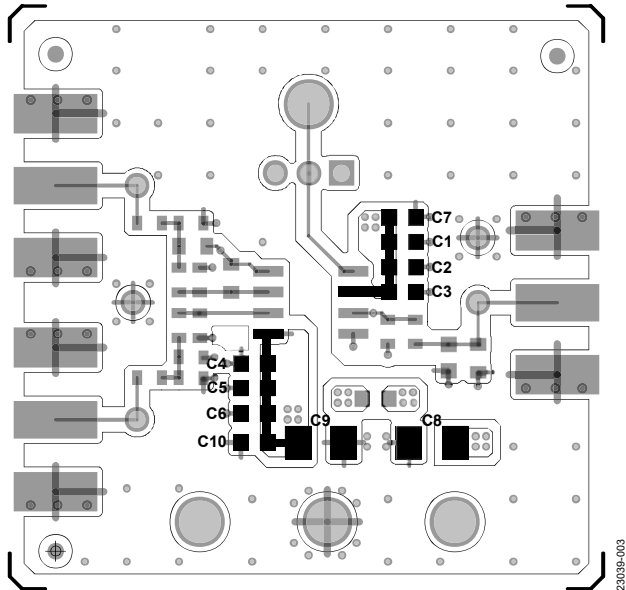

Figure 3. Bypass Capacitor Locations

EVALUATION BOARD STACK UP

The 4-layer board design of the EVAL-LTC6228IS8 (see Figure 4) provides optimized high speed and low noise performance. The upper ground layer is spaced to provide 50 Ω controlled impedance with the top signal layer to optimize high frequency performance.

The VCC/VEE power plane layer is in between the two ground layers to provide mechanical stability and distributed interplanar capacitance between the power plane layer and the ground layer.

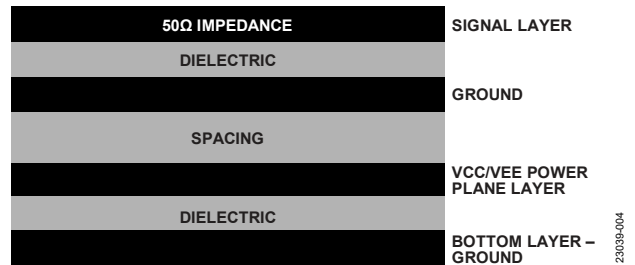
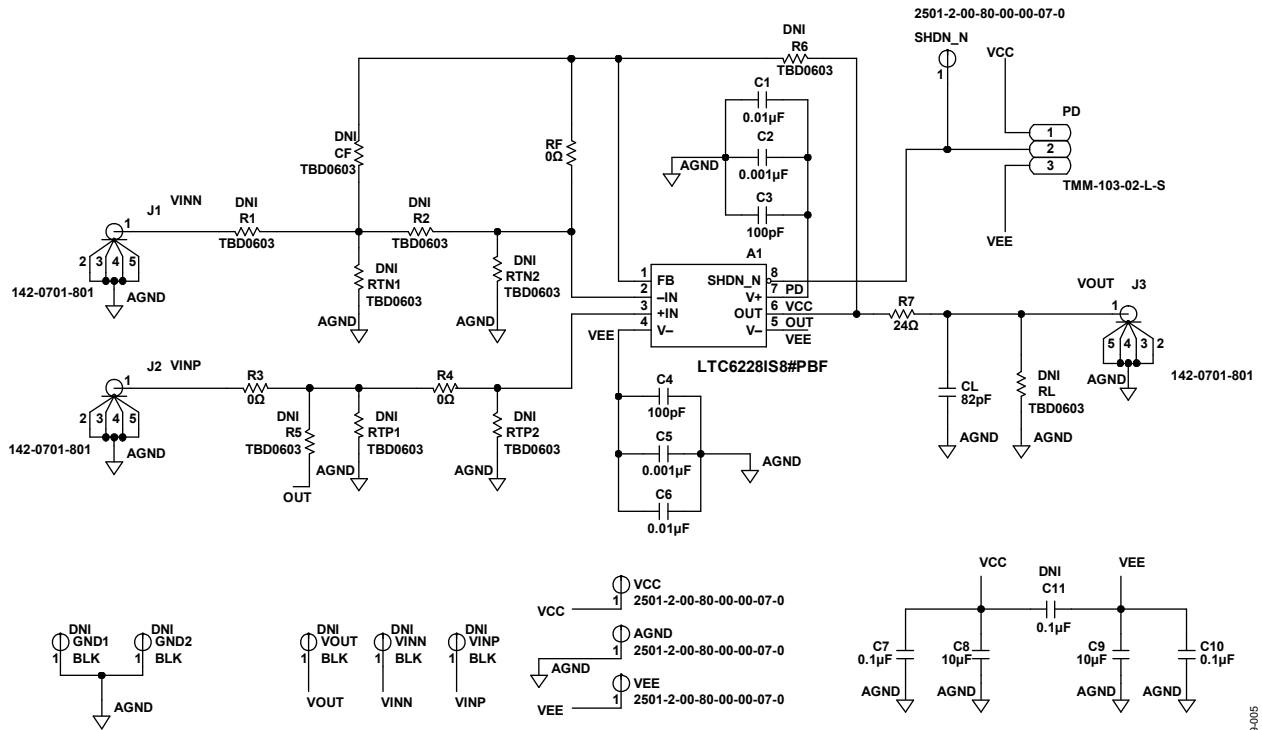

Figure 4. Stack Up

EVALUATION BOARD SCHEMATIC AND ARTWORK



EVAL-LTC6228IS8

Figure 5. EVAL-LTC6228IS8E Schematic

23039-005

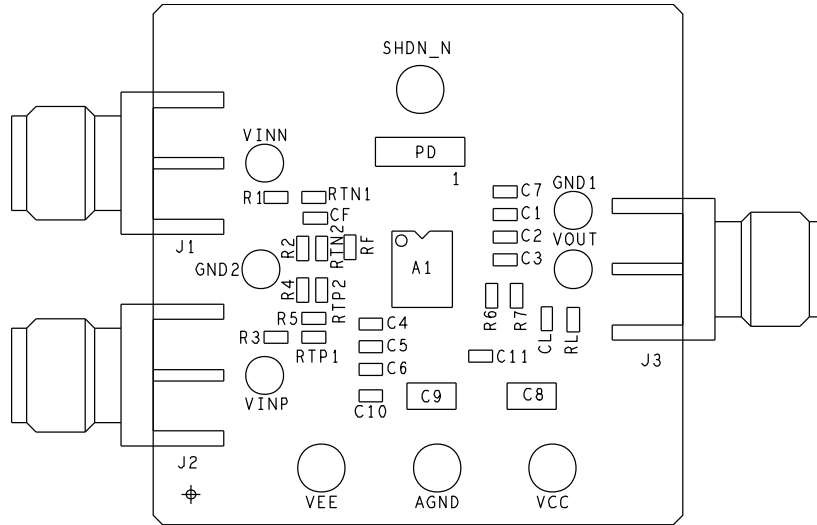

Figure 6. EVAL-LTC6228IS8E Assembly Drawing, Primary Side

23035-016

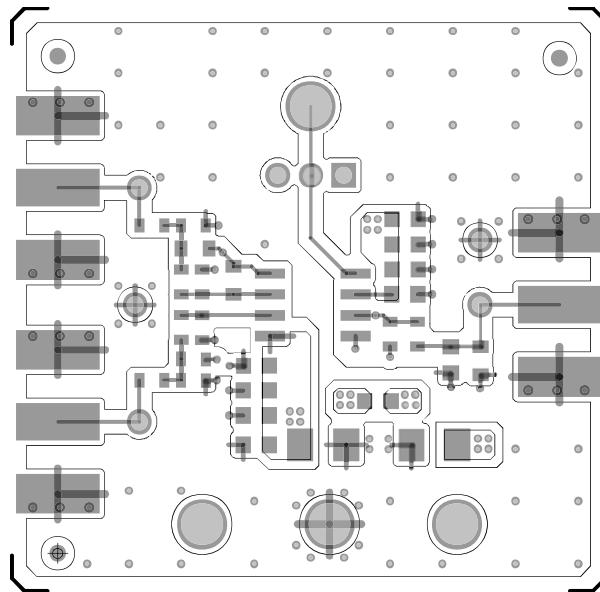

Figure 7. EVAL-LTC6228IS8E Layout Pattern, Primary Side

23039-007

ORDERING INFORMATION
BILL OF MATERIALS

Table 1.

Quantity	Reference Designator	Description	Part Number
1	A1	Rail-to-rail output op amp, LTC6228	LTC6228IS8#PBF
4	AGND, SHDN_N, VCC, VEE	Terminal turrets	2501-2-00-80-00-00-07-0
10	CF, R1, R2, R5, R6, RL, RTN1, RTN2, RTP1, RTP2	Resistors, user defined, do not install (DNI), R0603/R0402	Not applicable
1	CL	Capacitor, 82 pF, C0603	2238 867 15829
2	C1, C6	Capacitors, 0.01 μF, C0603	CC0603KRX7R9BB103
2	C2, C5	Capacitors, 0.001 μF, C0603	CC0603KRX7R9BB102
2	C3, C4	Capacitors, 100 pF, C0603	C0603C101K5RAC
2	C7, C10	Capacitors, 0.1 μF, C0603	06035C104KAT2A
2	C8, C9	Capacitors, 10 μF, C1206	GMK316AB7106KL-TR
1	C11	Capacitor, 0.1 μF, DNI, C0603	Not applicable
5	GND1, GND2, VINN, VINP, VOUT	Test points	5001
3	J1, J2, J3	SMA end launch connectors	142-0701-801
1	PD	Pin header	TMM-103-02-L-S
3	R3, R4, FR	Resistors, 0 Ω, R0603	MC0603WG00000T5E-TC
1	R7	Resistor, 24 Ω, R0603	MC 0.063W 0603 1% 24R.

Legal Terms and Conditions

By using the evaluation board discussed herein (together with any tools, components documentation or support materials, the "Evaluation Board"), you are agreeing to be bound by the terms and conditions set forth below ("Agreement") unless you have purchased the Evaluation Board, in which case the Analog Devices Standard Terms and Conditions of Sale shall govern. Do not use the Evaluation Board until you have read and agreed to the Agreement. Your use of the Evaluation Board shall signify your acceptance of the Agreement. This Agreement is made by and between you ("Customer") and Analog Devices, Inc. ("ADI"), with its principal place of business at One Technology Way, Norwood, MA 02062, USA. Subject to the terms and conditions of the Agreement, ADI hereby grants to Customer a free, limited, personal, temporary, non-exclusive, non-sublicensable, non-transferable license to use the Evaluation Board FOR EVALUATION PURPOSES ONLY. Customer understands and agrees that the Evaluation Board is provided for the sole and exclusive purpose referenced above, and agrees not to use the Evaluation Board for any other purpose. Furthermore, the license granted is expressly made subject to the following additional limitations: Customer shall not (i) rent, lease, display, sell, transfer, assign, sublicense, or distribute the Evaluation Board; and (ii) permit any Third Party to access the Evaluation Board. As used herein, the term "Third Party" includes any entity other than ADI, Customer, their employees, affiliates and in-house consultants. The Evaluation Board is NOT sold to Customer; all rights not expressly granted herein, including ownership of the Evaluation Board, are reserved by ADI. CONFIDENTIALITY. This Agreement and the Evaluation Board shall all be considered the confidential and proprietary information of ADI. Customer may not disclose or transfer any portion of the Evaluation Board to any other party for any reason. Upon discontinuation of use of the Evaluation Board or termination of this Agreement, Customer agrees to promptly return the Evaluation Board to ADI. ADDITIONAL RESTRICTIONS. Customer may not disassemble, decompile or reverse engineer chips on the Evaluation Board. Customer shall inform ADI of any occurred damages or any modifications or alterations it makes to the Evaluation Board, including but not limited to soldering or any other activity that affects the material content of the Evaluation Board. Modifications to the Evaluation Board must comply with applicable law, including but not limited to the RoHS Directive. TERMINATION. ADI may terminate this Agreement at any time upon giving written notice to Customer. Customer agrees to return to ADI the Evaluation Board at that time. LIMITATION OF LIABILITY. THE EVALUATION BOARD PROVIDED HEREUNDER IS PROVIDED "AS IS" AND ADI MAKES NO WARRANTIES OR REPRESENTATIONS OF ANY KIND WITH RESPECT TO IT. ADI SPECIFICALLY DISCLAIMS ANY REPRESENTATIONS, ENDORSEMENTS, GUARANTEES, OR WARRANTIES, EXPRESS OR IMPLIED, RELATED TO THE EVALUATION BOARD INCLUDING, BUT NOT LIMITED TO, THE IMPLIED WARRANTY OF MERCHANTABILITY, TITLE, FITNESS FOR A PARTICULAR PURPOSE OR NON-INFRINGEMENT OF INTELLECTUAL PROPERTY RIGHTS. IN NO EVENT WILL ADI AND ITS LICENSORS BE LIABLE FOR ANY INCIDENTAL, SPECIAL, INDIRECT, OR CONSEQUENTIAL DAMAGES RESULTING FROM CUSTOMER'S POSSESSION OR USE OF THE EVALUATION BOARD, INCLUDING BUT NOT LIMITED TO LOST PROFITS, DELAY COSTS, LABOR COSTS OR LOSS OF GOODWILL. ADI'S TOTAL LIABILITY FROM ANY AND ALL CAUSES SHALL BE LIMITED TO THE AMOUNT OF ONE HUNDRED US DOLLARS (\$100.00). EXPORT. Customer agrees that it will not directly or indirectly export the Evaluation Board to another country, and that it will comply with all applicable United States federal laws and regulations relating to exports. GOVERNING LAW. This Agreement shall be governed by and construed in accordance with the substantive laws of the Commonwealth of Massachusetts (excluding conflict of law rules). Any legal action regarding this Agreement will be heard in the state or federal courts having jurisdiction in Suffolk County, Massachusetts, and Customer hereby submits to the personal jurisdiction and venue of such courts. The United Nations Convention on Contracts for the International Sale of Goods shall not apply to this Agreement and is expressly disclaimed.

©2019 Analog Devices, Inc. All rights reserved. Trademarks and registered trademarks are the property of their respective owners.
UG23039-0-12/19(0)



www.analog.com