

83160 Reduced force 831603 Part number 83160301



- Nominal ratings up to 16 A / 250 VAC
- Self-cleaning contacts
- 3 mm contact gap for type 83 160 6
- High DC switch rating for type 83 160 6 SP 3697
- Choice of actuators
- Approvals NF - UL (except 83 160 6 SP 3697)

Part numbers

Type	Function	Connections
83160301 Reduced force 831603	I (changeover)	W3

Specifications

Electrical characteristics

Rating nominal / 250 VAC (A)	10
Rating thermal / 250 VAC (A)	15
Rating nominal / 250 VDC (A)	-
Rating thermal / 250 VDC (A)	-

Mechanical characteristics

Maximum operating force (N)	2
Min. Release force (N)	0,6
Maximum total travel force (N)	3
Max. permitted overtravel force (N)	20
Maximum rest position (mm)	15,6
Operating position (mm)	14,8 ±0,3
Maximum differential travel (mm)	0,4
Min. overtravel CRA (mm)	1,3
Ambient operating temperature (°C)	-20 → +125
Mechanical life for 2/3 CRA (operations)	10 ⁷
Contact gap (mm)	1,2
Weight (g)	6,7

Comments

* X1 for 831606 and 831606 SP 3697 : please consult us

Additional specifications

Components

Material

- Case : 83 160 0, 3, 4 and 6 polyamide UL94VO.
- Contacts : nickel silver

Lever

- stainless steel
- polyamide roller

Approvals : NF

Principles

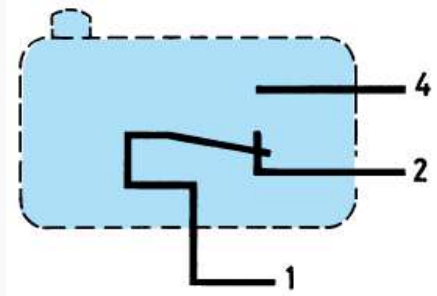

Dimensions (mm)

Product

831600/3/4/6

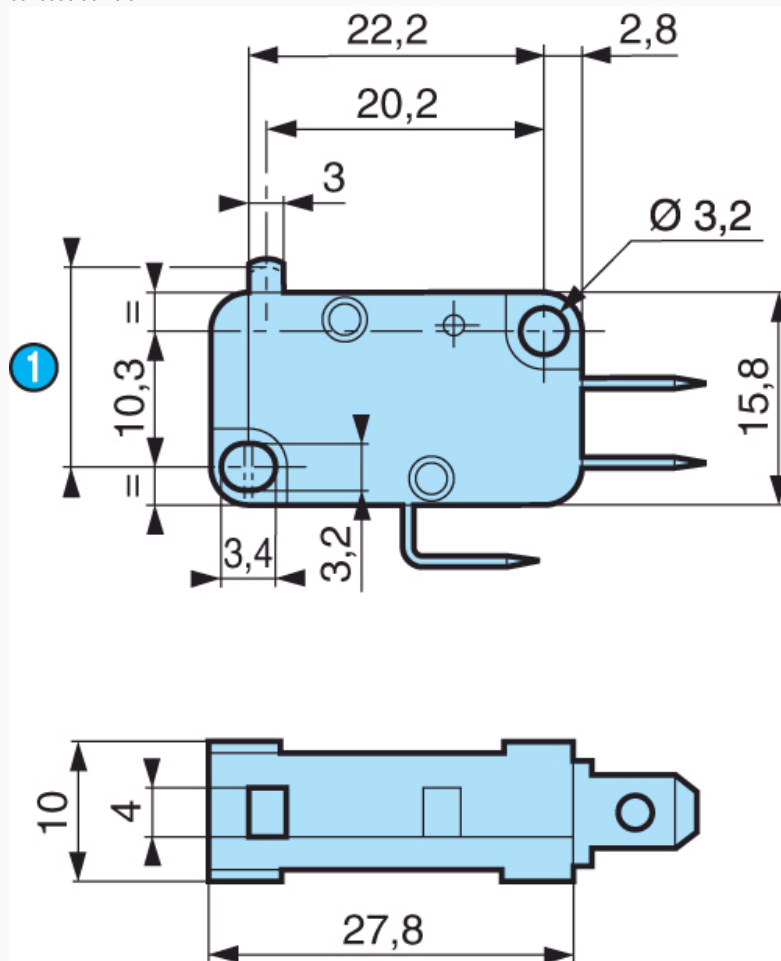

N°	Legend
①	OL = 13.2 max.

Dimensions (mm)

Connections

W2 solder

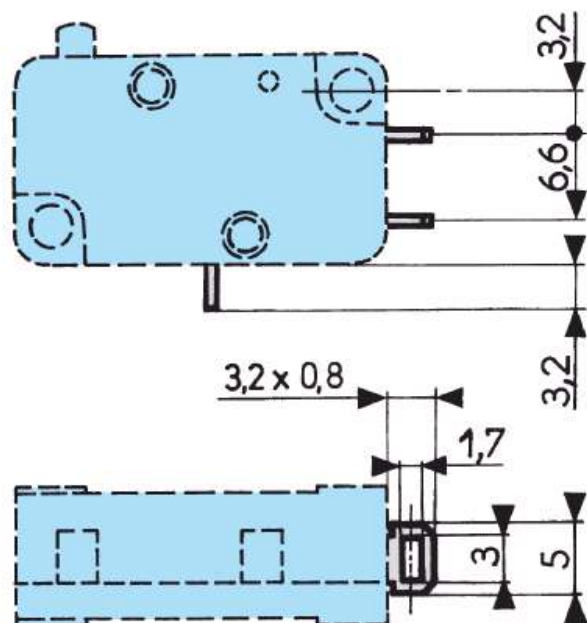

Dimensions (mm)

Connections

W3 for 6.35 mm clips

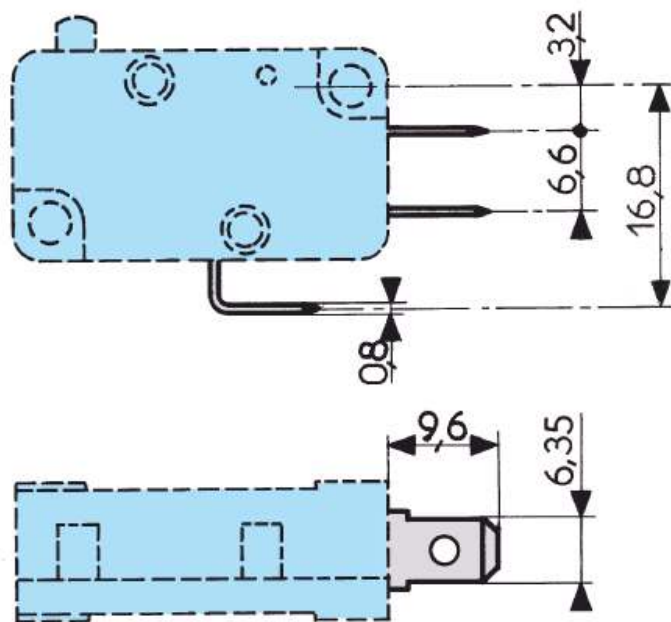

Dimensions (mm)

Connections

W6 for 4.75 mm clips

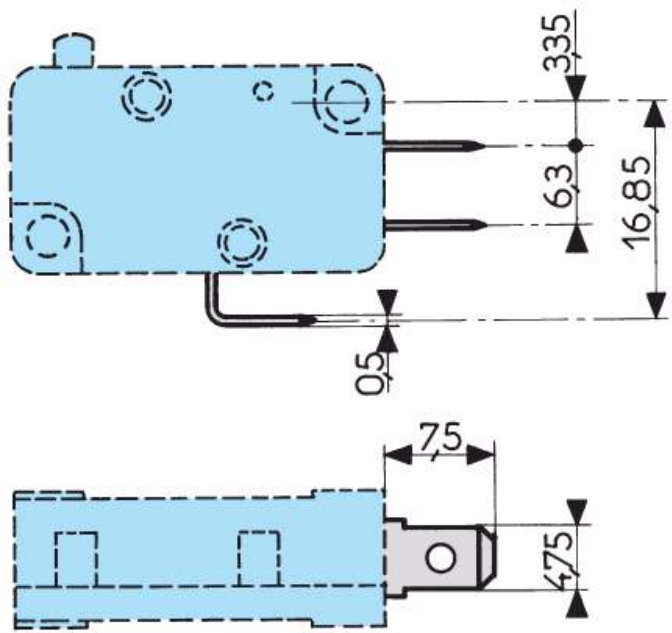

Dimensions (mm)

Connections

X1 printed circuit board

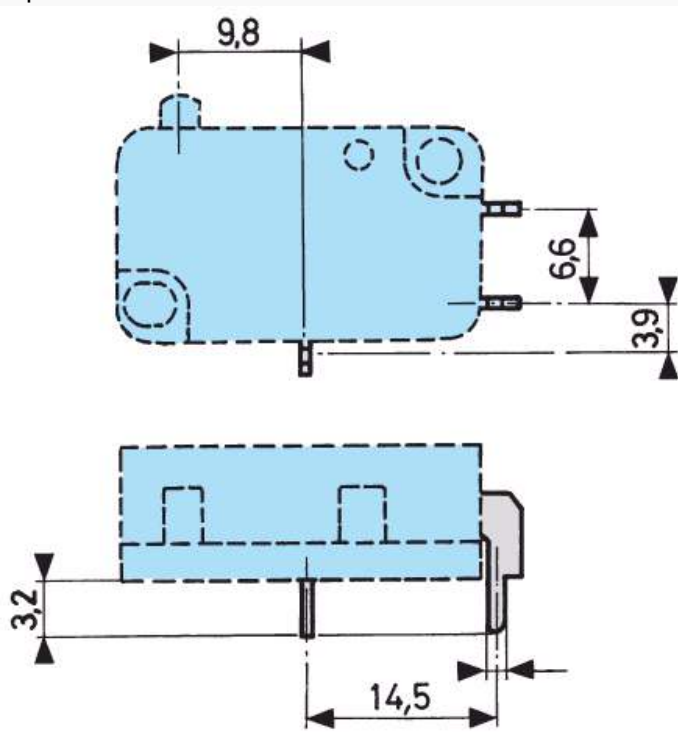

Dimensions (mm)

Actuator mounting positions

Fixing position

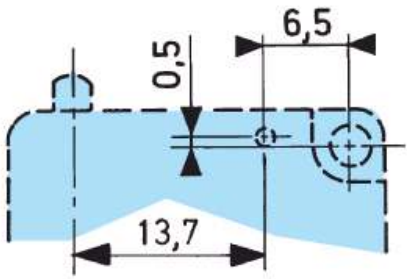

Dimensions (mm)

Actuators

153 AX

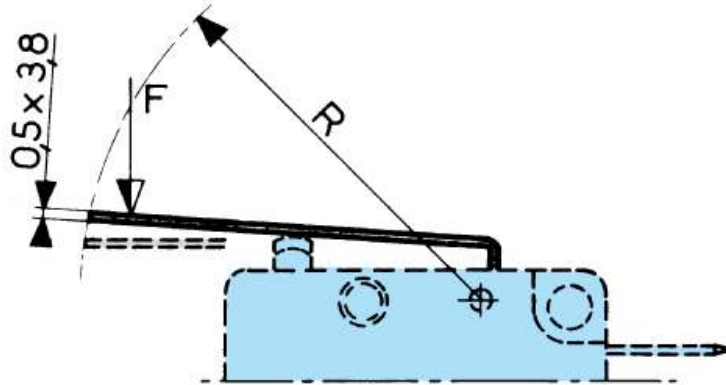

Dimensions (mm)

Actuators

153 EX

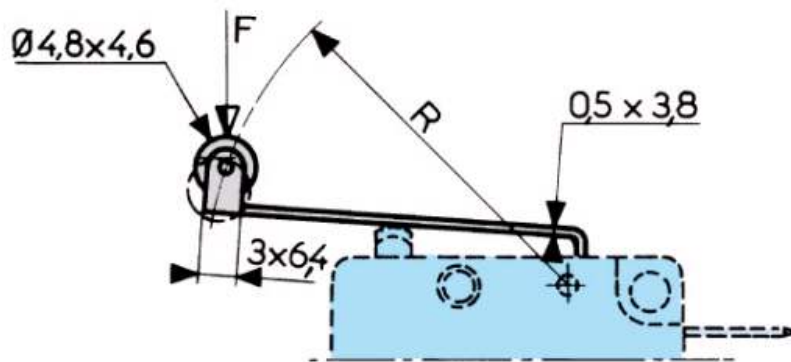

Curves

Operating curve for types 831600 / 3 / 4 / 6

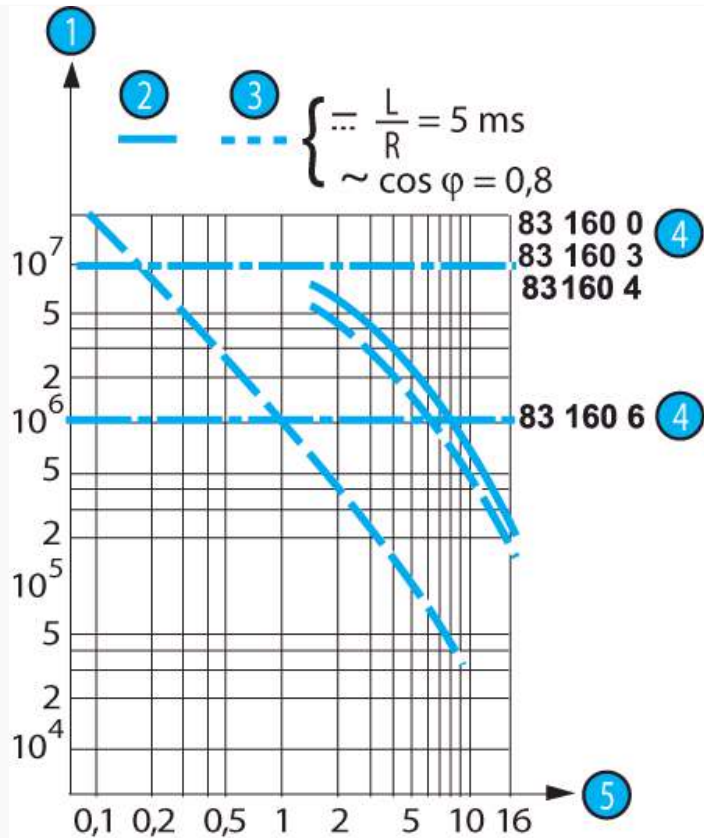

N°	Legend
1	Number of cycles
2	Resistive circuit
3	Inductive circuit
4	Mechanical life limit
5	Current in Amps

Connections

Actuators and fixing positions

Part numbers for standard actuators					
	70 545 0 / 153 A R29.7	70 545 0 / 153 E R15.8	70 545 0 / 153 E R28.7		
Actuators	Flat 153 AX R29.7	Roller 153 EX R15.8	Roller 153 EX R28.7		
	83 1600 83 1603 83 1606	83 1600 83 1603 83 1606	83 1600 83 1603 83 1606		
Fixing positions	15.3 ^(A) 15.3 ^(A) 14.4 ^(A)	20.5 ^{(A)(B)} 20.5 ^{(A)(B)} 20.3 ^{(A)(B)}	20.5 ^{(A)(B)} 20.5 ^{(A)(B)} 19.6 ^{(A)(B)}		
Operating force - max.	2 1 2.6	4 2 5	2 1 2.6		
Release force - min.	0.4 0.25 0.3	1 0.55 0.75	0.4 0.25 0.3		
Pre-travel - max.	2.5 2.5 3.1	1.2 1.2 1.4	2.5 2.5 3.1		
Differential travel max.	0.6 0.8 1.5	0.3 0.4 0.7	0.6 0.8 1.5		
Total travel max.	2.3 2.3 2.3	2.3 2.3 2.3	4.6 4.6 4.6		
	2-pole 153 A2** R15.9	Dummy roller F** R24.3	Telescopic plunger 153L** (operating temperature 125°C max.)	Flexible with roller 153 B**	153 V**

** Please consult us

Other information

Mounting - Operation

See basic technical concepts

Product adaptations



- Special levers
- Approvals : NF - UL for 83 160 6 SP 3697