

二重ダイアフラム構造 圧カスイッチ PRESSURE SWITCHES

PS83

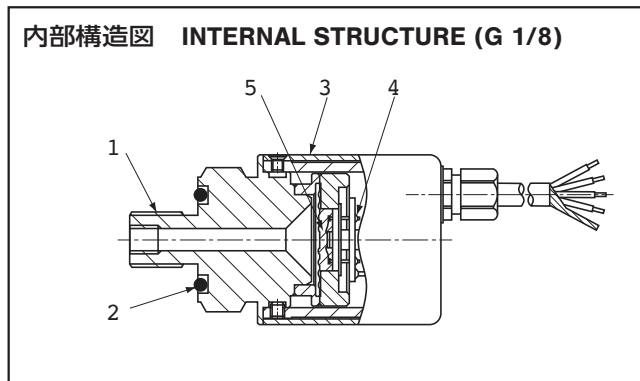

■特長 FEATURES

- 可動部分を持たない電子式圧カスイッチ
 - 耐食性に優れた二重ダイアフラム構造
 - 独立 2 点設定タイプ
 - 多種の媒体に対応可能
 - * VCR® を使用した製品も対応
- Solidstate pressure switch with no mechanical moving parts
 - High corrosion resistance by double diaphragm structure
 - Two pressure setting points
 - Wide pressure medium compatibility
 - Can be attached with a * VCR® fitting

名称 Part name	材料 Material
① 継手 Fitting	SUS 316L
② Oリング (P15 or P12.5) "O" ring	フッ素ゴム Fluoro-rubber
③ ケース Housing	アルミニウム Aluminum
④ 補償抵抗基板 Compensation resistor board	セラミック Ceramic
⑤ 封入液 Sealed liquid	シリコンオイル Silicone oil

■型式表示 MODEL NUMBER DESIGNATION

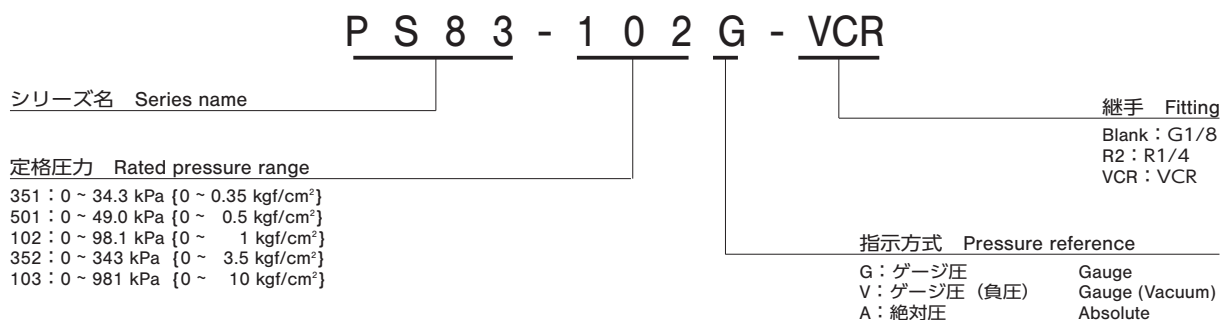

※ご注文に際しては、型式一覧表をご確認ください。

Please refer to the LIST OF MODEL NUMBERS when placing orders.

※ VCR® は、CAJON CO. の登録商標です。CAJON® は、SWAGELOK CO. の登録商標です。

VCR® is a registered trade name of Cajon Co. CAJON® is a registered trade name of Swagelok Co.

注) VCR® 継手の取扱いについては、SWAGELOK CO. の指定販売サービス会社にお問い合わせ願います。
Note: For handling of VCR fittings, please contact a service center of Swagelok Co.

■ 型式一覧表 LIST OF MODEL NUMBERS

形 (指示方式) Pressure reference	ゲージ圧 Gauge					絶対圧 Absolute	
	圧力ポート / 定格圧力 kPa {kgf/cm ² } Pressure port / Rated pressure range	0 ~ 49.0 {0 ~ 0.5}	0 ~ 98.1 {0 ~ 1}	0 ~ 343 {0 ~ 3.5}	0 ~ 981 {0 ~ 10}	0 ~ -98.1 {0 ~ -1}	0 ~ 34.3 {0 ~ 0.35}
G 1/8 (PF 1/8)	PS83-501G	PS83-102G	PS83-352G	PS83-103G	PS83-102V	PS83-351A	PS83-102A
R 1/4 (PT 1/4)	PS83-501G-R2	PS83-102G-R2	PS83-352G-R2	PS83-103G-R2	PS83-102V-R2	PS83-351A-R2	PS83-102A-R2
VCR(9/16-18UNF)	PS83-501G-VCR	PS83-102G-VCR	PS83-352G-VCR	PS83-103G-VCR	PS83-102V-VCR	PS83-351A-VCR	PS83-102A-VCR

※ご注文に際しては、上記型式をご確認ください。

※ Verify the above model numbers when placing orders.

■ 標準仕様 STANDARD SPECIFICATIONS

● 特記ない場合、周囲温度 25 ± 5 °C、駆動電圧 12 V DC で規定します。

Unless otherwise specified, the specs are defined at an ambient temperature of 25 ± 5 °C and excitation voltage of 12 V DC.

項目 Item	型式 Model number	PS83						
		501G	102G	102V	352G	103G	351A	102A
形 (指示方式) Pressure reference		ゲージ圧 Gauge					絶対圧 Absolute	
定格圧力 Rated pressure range	kPa {kgf/cm ² }	49.0 {0.5}	98.1 {1}	-98.1 {-1}	343 {3.5}	981 {10}	34.3 (abs) {0.35}	98.1 (abs) {1}
最大圧力 Maximum pressure	kPa {kgf/cm ² }	98.1 {1}	196 {2}		686 {7}	1961 {20}	103 (abs) {1.05}	196 (abs) {2}
破壊圧力 Break-down pressure	kPa {kgf/cm ² }	147 {1.5}	294 {3}		1030 {10.5}	2941 {30}	147 (abs) {1.5}	294 (abs) {3}
動作温度 Operating temp. range	°C	-20 ~ 70						
補償温度 Compensated temp. range	°C	0 ~ 50						
動作湿度 Operating humidity	%RH	35 ~ 85 (結露しないこと No condensation)						
保存温度 Storage temp.	°C	-20 ~ 70 (大気圧、湿度 65%RH 以下 Atmospheric pressure humidity 65 %RH maximum)						
適用媒体 Pressure medium		SUS 316L を腐食させない気体及び液体 Corrosive gases/liquids compatible with SUS 316L ※ 1						
絶縁抵抗 Insulation resistance	MΩ minimum	100 (500 V DC)						
耐電圧 Dielectric strength		500 V AC, 60 s (リーク電流 1mA 以下 Leakage current 1mA maximum)						
封入液 Sealed liquid		シリコンオイル Silicone oil						
圧力ポート Pressure port		G 1/8 (PF 1/8) ※ 2, R 1/4 (PT 1/4), 1/4 VCR®						
質量 Net weight	g	Approx. 140						
電源 Power	駆動電圧 Supply voltage	V DC 12 ~ 24 ± 10 %						
	リップル含有率 Ripple content	maximum 10 % (P-P) maximum						
	消費電流 Consumption current	maximum 20 mA						

※ 1 PS83-□□□□-VCR の場合、SUS 316 を含む

※ 1 : Also compatible with SUS316 in case of PS83-□□□□-VCR.

※ 2 G 1/8 継手の場合は O リング付属
(正圧 : P15、負圧 / 絶対圧 : P12.5)

※ 2 : In case of G 1/8 type, An "O" ring is supplied as accessory.
(P15 for positive press., P12.5 for negative / absolute press.)

PS83

PRESSURE SWITCHES

項目 Item	型式 Model number	PS83							
		501G	102G	102V	352G	103G	351A	102A	
スイッチ出力 Switch output	出力点数 No. of output	2							
	出力方式 Output interface	NPN オープンコレクタ NPN open collector output							
	設定方式 Setting method	トリマによる可変式 Adjustable by VR							
	設定範囲 Adjustable range	定格圧力範囲以上 Zero through rated pressure, minimum							
	出力表示 Display	赤色 LED 点灯 (出力 ON 時) Red LED (lighted when output is ON.)							
	精度 Accuracy	0 ~ 50 °C (基準温度 25 °C) (Reference temp.: 25 °C)		% F.S.					± 3
	応差 Hysteresis	% F.S. maximum		2					
	スイッチ容量 Switching capacity	30 V DC 80 mA maximum							
	残留電圧 Residual voltage	V maximum		0.8					
応答速度 Response	ms		Approx. 2						

環境特性 ENVIRONMENTAL CHARACTERISTICS

試験項目 Test item	試験方法 (条件 25 ± 5 °C) Test conditions (At 25 ± 5 °C)	変動量 Permissible change
振動 Vibration	10 ~ 500 Hz, 1.5 mm maximum/98.1 m/s ² , 3 directions for 2 hours each	スイッチ出力設定値最大 ± 1 %F.S. Switch output setting: ± 1 %F.S. maximum
衝撃 Shock	490 m/s ² , 3 directions for 3 times each	
圧力サイクル Pressure cycling	0 ~ 定格圧力 0 ~ Rated pressure, 10 ⁶ cycles	
耐湿性 Moisture resistance	40 °C, 90 ~ 95 %RH, 240 hrs.	

内部電気回路 INTERNAL ELECTRICAL SCHEMATICS

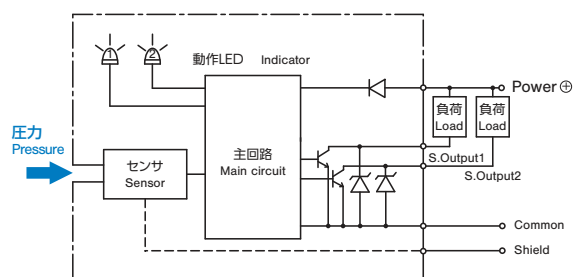

スイッチ動作 SWITCHING OPERATION

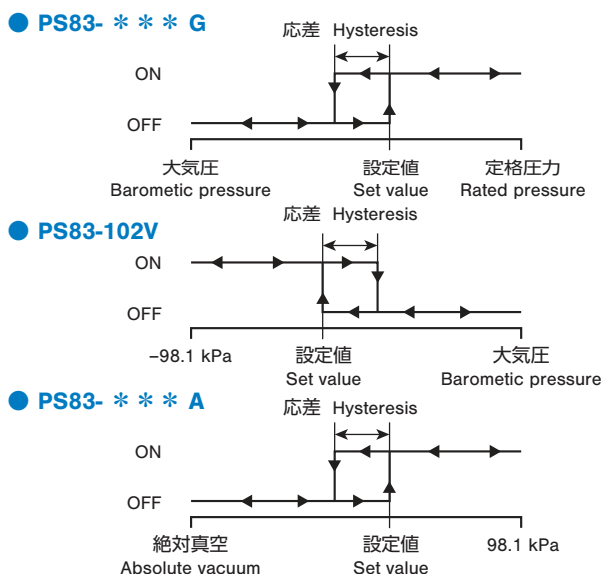

※スイッチ 2 点とも同一動作 2 switches show same performance.

PS83 PRESSURE SWITCHES

外形寸法図 OUTLINE DIMENSIONS

Unless otherwise specified, tolerance : ± 0.5 (Unit: mm)

● PS83 (G 1/8 タイプ G 1/8 type)

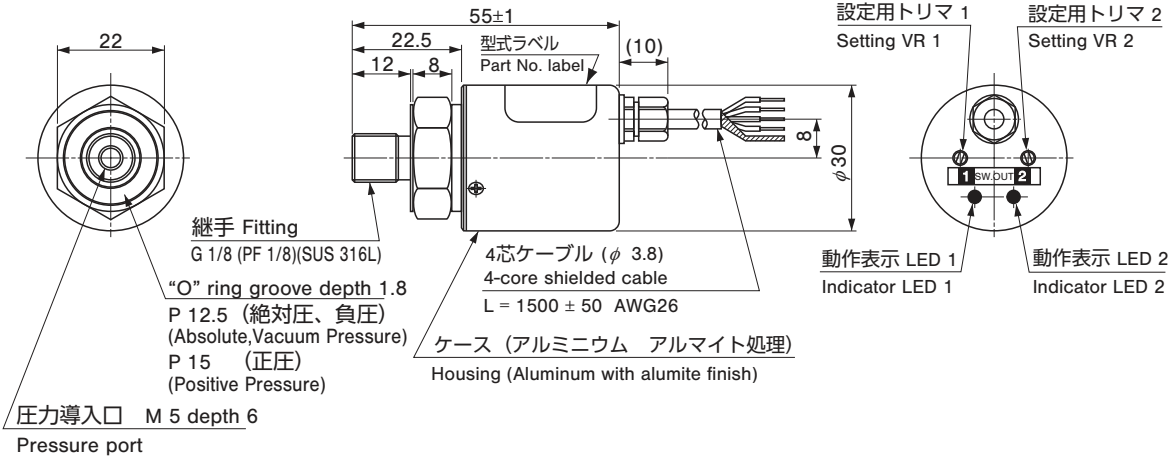

● PS83 (R1/4 タイプ R1/4 type)

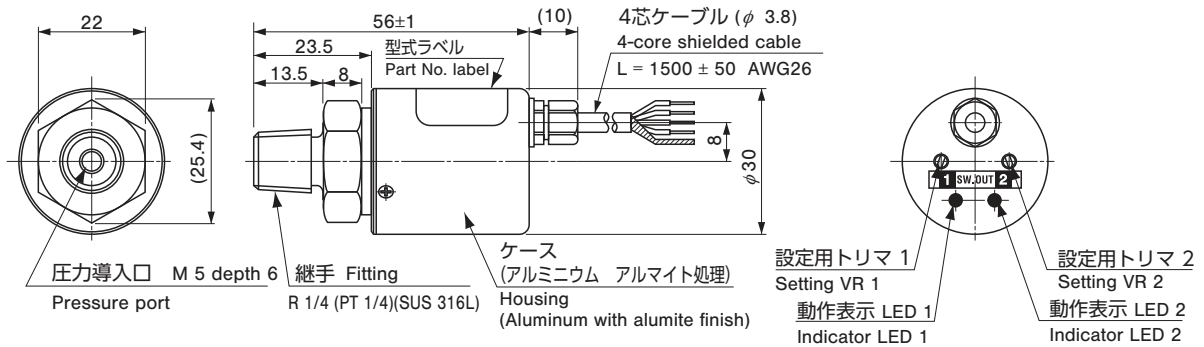

● PS83 (VCR タイプ VCR type)

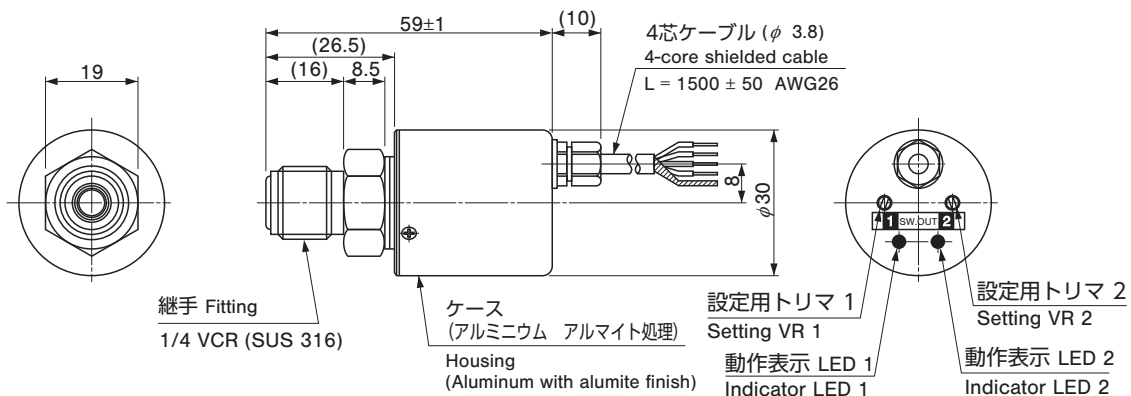

Wire color	Connection
Red	Power ⊕
Green	Output 1
White	Output 2
Black	Common
Shield	Fitting