

# Board Level Heat Sinks

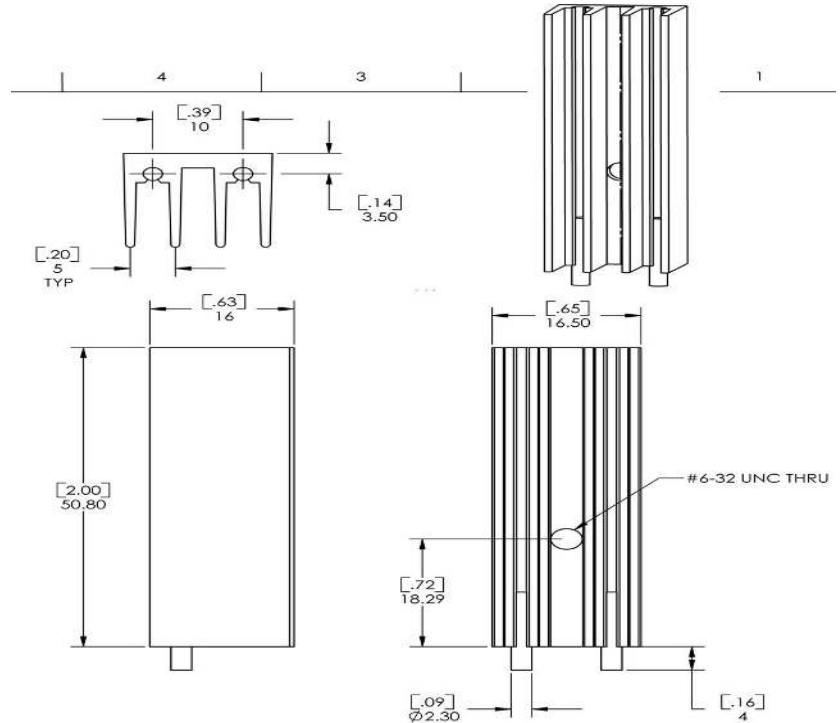

ThermaFlo

P/N: 412320B02500



## PRODUCT SPECIFICATIONS

- Devices: TO-218 & TO-220
- Size: 16.0 x 16.5 x 50.8 mm
- Material: Aluminum
- Type: Extruded
- PCB Mounting: Solderable Pins
- Finish: Black Anodized
- Package: Bulk
- Accessories: Hardware & Thermal Interface Material

## FEATURES & BENEFITS

- Tapped Hole for Device Attachment
- Vertical Mounting via Solderable Pins
- RoHS Compliant



## CUSTOMIZED HEATSINKS

- Specialized Plating
- Specialized Body Configurations
- Contact Applications Engineering

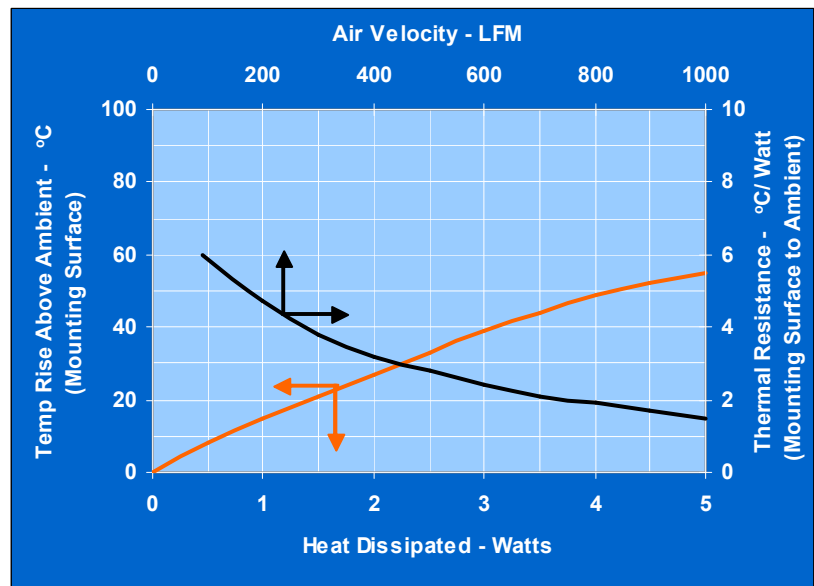

TO-218 & TO-220