

THIS DRAWING IS UNPUBLISHED. RELEASED FOR PUBLICATION 21-FEB-1996
 © COPYRIGHT 1996 BY TYCO ELECTRONICS CORPORATION. ALL RIGHTS RESERVED.

LOC	DIST	REVISIONS			
P	LTR	DESCRIPTION	DATE	DWN	APVD
E	B	G	ECR-07-015707	13/06/07	MJG JA
		H	ECR-10-010252	24/05/10	MJG JA

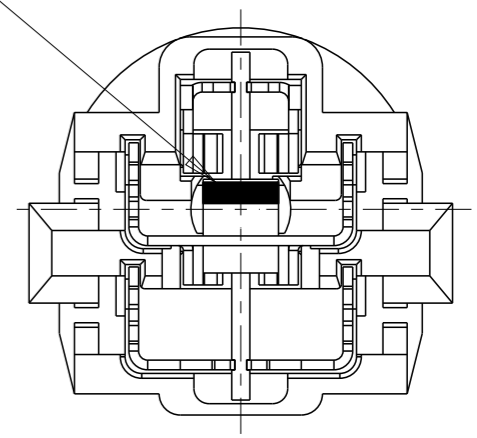
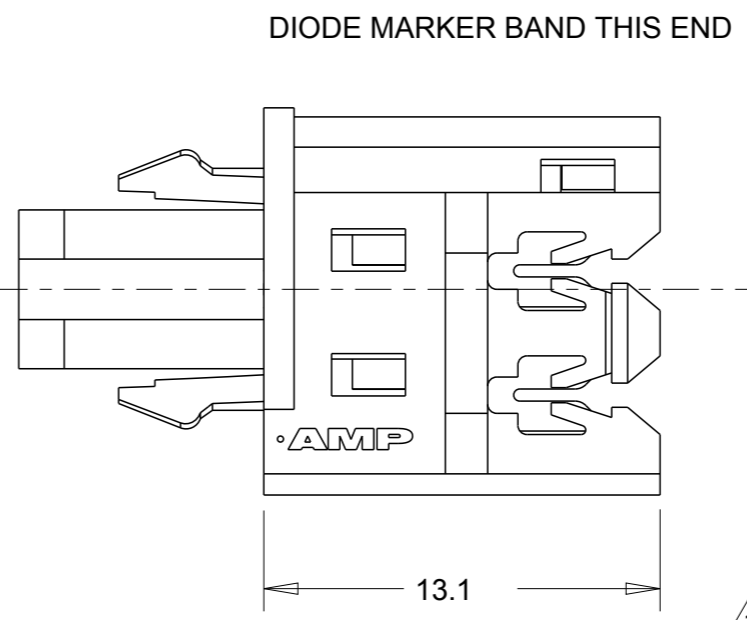
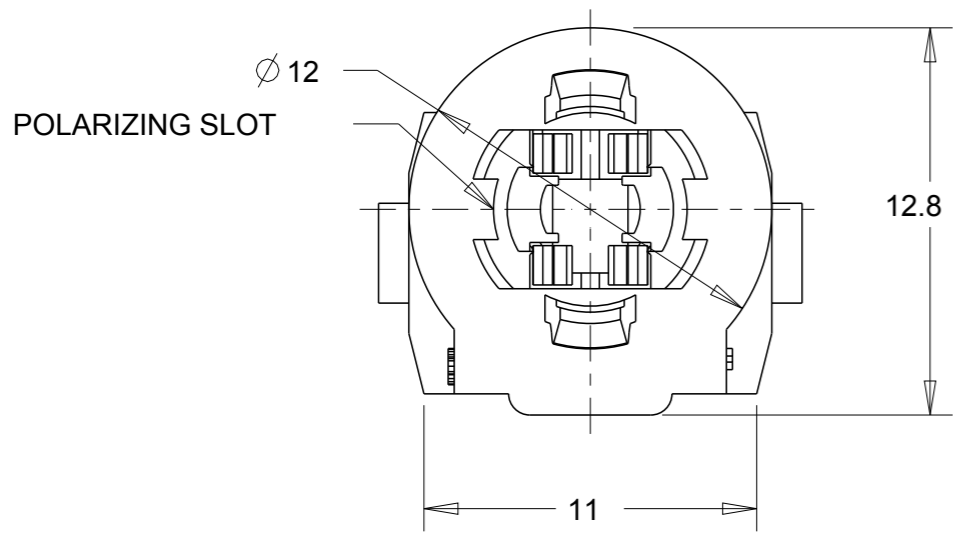

1 MATERIALS
 HOUSING :- NYLON 66
 CONTACTS :- BRASS

2 AMP PRODUCT SPEC No 108-3382.

3 AMP APPLICATION SPEC No 114-3185.

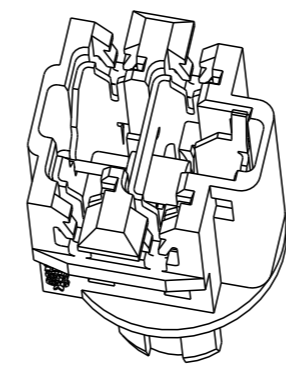
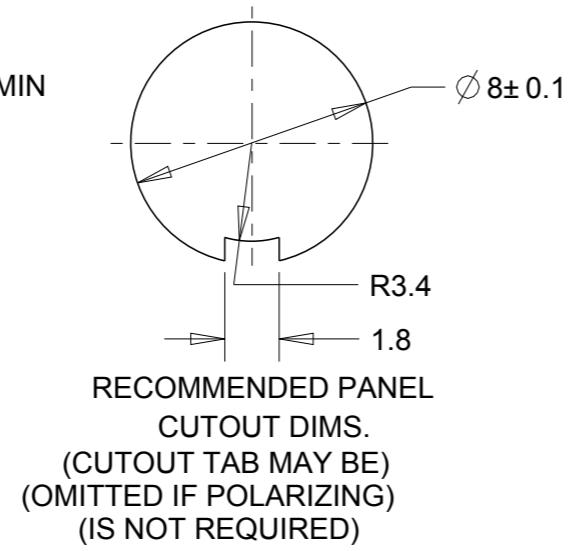
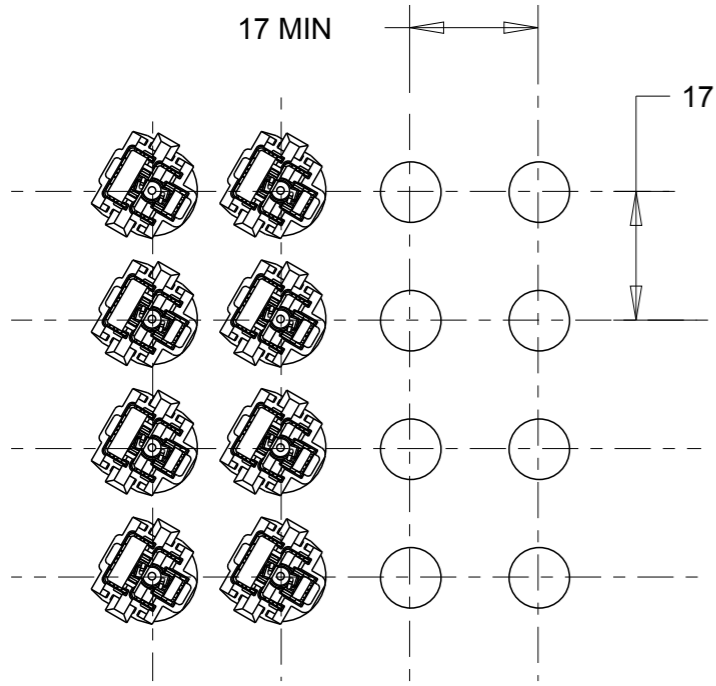

RECOMMENDED MAXIMUM PANEL DENSITY FOR MANUAL WIRE INSERTION TOOLS. CONSULT AMP FOR PITCHING DIMENSIONS IF USING POWERED TOOLS. SCALE 1:1
 PANEL THICKNESS 1.5 TO 2.0

THIS DRAWING IS A CONTROLLED DOCUMENT FOR TYCO ELECTRONICS CORPORATION IT IS SUBJECT TO CHANGE AND THE CONTROLLING ENGINEERING ORGANIZATION SHOULD BE CONTACTED FOR THE LATEST REVISION.

DIMENSIONS:	TOLERANCES UNLESS OTHERWISE SPECIFIED:
mm	LINEAR ± 0.5
	0-PLC ± 0.1
	1-PLC ± 0.1
	2-PLC ± 0.05
	3-PLC \pm
	4-PLC \pm
	ANGLES ± 0.5
MATERIAL	FINISH
1	-

BULBHOLDER WITHOUT BULB		349494-2	
DESCRIPTION		PART NUMBER	
Tyco Electronics UK Ltd, Stanmore, Middlesex, HA7 4RS. Tyco Electronics			
NAME		5mm IDC BULBHOLDER ASSEMBLY WITH DIODE	
SIZE	CAGE CODE	DRAWING NO	RESTRICTED TO
A3	00779	C-349494	-
CUSTOMER DRAWING		SCALE	SHEET
		5:1	1 OF 1
		REV	H