

**F<sup>2</sup>MC-16 Family EMULATOR**  
**LQFP-48P PROBE HEADER**  
**MB2147-521**  
**OPERATION MANUAL**

## PREFACE

Thank you for purchasing the LQFP-48P<sup>\*1</sup> probe header (MB2147-521) for the F<sup>2</sup>MC<sup>\*2</sup>-16 family emulator.

The LQFP-48P probe header is used to connect the F<sup>2</sup>MC-16L/16LX emulator (MB2147-01<sup>\*3</sup>) and the F<sup>2</sup>MC-16L/16LX emulator PGA-299P adapter board (MB2147-20<sup>\*4</sup>) to a user system. That uses Fujitsu F<sup>2</sup>MC<sup>\*1</sup> -16LX microcontroller MB90340 series (LQFP-48P).

This manual explains the handling of the LQFP-48P probe header for the F<sup>2</sup>MC-16 family emulator. Before using the MB2147-521, be sure to read this manual.

Consult the Sales representatives or the Support representatives of Fujitsu Limited for mass-produced MCUs and evaluation MCUs.

\*1 : The lead pitch of PACKAGE (FPT-48P-M26) is 0.5 mm and the body size is 7 mm × 7 mm.

\*2 : F<sup>2</sup>MC is the abbreviation used for FUJITSU Flexible Microcontroller.

\*3 : referred to as "emulator"

\*4 : referred to as "adapter board"

### ■ Handling and use

The handling and use of this product and notes regarding safety are included in the hardware manual of the F<sup>2</sup>MC-16 family emulator.

Follow the instructions in for the use of this product.

- F<sup>2</sup>MC-16/16LX EMULATOR MB2147-01 HARDWARE MANUAL
- F<sup>2</sup>MC-16/16LX EMULATOR PGA-299P ADAPTER BOARD MB2147-20 HARDWARE MANUAL

### ■ Caution of the products described in this document

The following precautions apply to the product described in this manual.



The wrong use of a device will give an injury and may cause malfunction on customers system.

|               |   |
|---------------|---|
| <b>Cuts</b>   | This product has parts with sharp points that are exposed.<br>Do not touch edge of the product with your bare hands.<br>There is a possibility that it may be injured.  |
| <b>Damage</b> | When connect the header board to the user system, correctly position the index mark (▲) on the NQPACK mounted on the user system with the index mark (▲) on the header board, otherwise the emulator system and user system might be damaged. |
| <b>Damage</b> | When mounting a mass production MCU, correctly position pin 1, otherwise the mass production MCU and user system might be damaged.  |

- The contents of this document are subject to change without notice.  
Customers are advised to consult with FUJITSU sales representatives before ordering.
- The information, such as descriptions of function and application circuit examples, in this document are presented solely for the purpose of reference to show examples of operations and uses of FUJITSU semiconductor device; FUJITSU does not warrant proper operation of the device with respect to use based on such information. When you develop equipment incorporating the device based on such information, you must assume any responsibility arising out of such use of the information. FUJITSU assumes no liability for any damages whatsoever arising out of the use of the information.
- Any information in this document, including descriptions of function and schematic diagrams, shall not be construed as license of the use or exercise of any intellectual property right, such as patent right or copyright, or any other right of FUJITSU or any third party or does FUJITSU warrant non-infringement of any third-party's intellectual property right or other right by using such information. FUJITSU assumes no liability for any infringement of the intellectual property rights or other rights of third parties which would result from the use of information contained herein.
- The products described in this document are designed, developed and manufactured as contemplated for general use, including without limitation, ordinary industrial use, general office use, personal use, and household use, but are not designed, developed and manufactured as contemplated (1) for use accompanying fatal risks or dangers that, unless extremely high safety is secured, could have a serious effect to the public, and could lead directly to death, personal injury, severe physical damage or other loss (i.e., nuclear reaction control in nuclear facility, aircraft flight control, air traffic control, mass transport control, medical life support system, missile launch control in weapon system), or (2) for use requiring extremely high reliability (i.e., submersible repeater and artificial satellite).  
Please note that FUJITSU will not be liable against you and/or any third party for any claims or damages arising in connection with above-mentioned uses of the products.
- Any semiconductor devices have an inherent chance of failure. You must protect against injury, damage or loss from such failures by incorporating safety design measures into your facility and equipment such as redundancy, fire protection, and prevention of over-current levels and other abnormal operating conditions.
- If any products described in this document represent goods or technologies subject to certain restrictions on export under the Foreign Exchange and Foreign Trade Law of Japan, the prior authorization by Japanese government will be required for export of those products from Japan.

## 1. Checking the Delivered Product

Before using the LQFP-48P probe header, confirm that the following components are included in the box:

- LQFP-48P Header board \*1 : 1
- Screws for securing header board (M2 × 10 mm, 0.4 mm pitch) : 4
- Washer : 4
- NQPACK048SD\*2 : 1
- HQPACK048SD\*3 : 1
- Operation manual (Japanese version) : 1
- Operation manual (English version, this manual) : 1

\*1 : Referred to as "header board". Header board is mounted on the probe connector and YQPACK048SD (Tokyo Eletech Corporation), referred to as "YQPACK".

\*2 : IC socket manufactured by Tokyo Eletech Corporation, referred to as "NQPACK", and supplied with a special screwdriver and 2 guide pins. A socket offering higher reliability, NQPACK048SD-SL (Tokyo Eletech Corporation, sold separately), can be used by making an IC socket mounting hole on the user system board. For more information, contact Tokyo Eletech Corporation.

\*3 : IC Socket cover manufactured by Tokyo Eletech Corporation, referred to as "HQPACK", with 4 screws for securing HQPACK (M2 × 6 mm, 0.4 mm pitch).

This product is used as an emulator system by combining with an optional emulator and adapter board.

Consult the Sales Department or the Support Department of Fujitsu Limited for the adapter or the emulator of this product.

## 2. Handling Precautions

The adapter unit is precision-manufactured to improve dimensional accuracy and to ensure reliable contact. The header is therefore sensitive to mechanical shock. To ensure correct use of the header in the proper environment, observe the following points regarding its insertion and removal:

- To avoid placing stress on the NQPACK mounted on the user system board during connecting the adapter unit.

### 3. Notes on Designing

#### ■ Restrictions of PC board for the user system

Once the header board is connected to the user system, the heights of parts mounted in the space around the header board are restricted.

The PC board of the user system must be designed with due consideration given to this restriction (Figure 1).

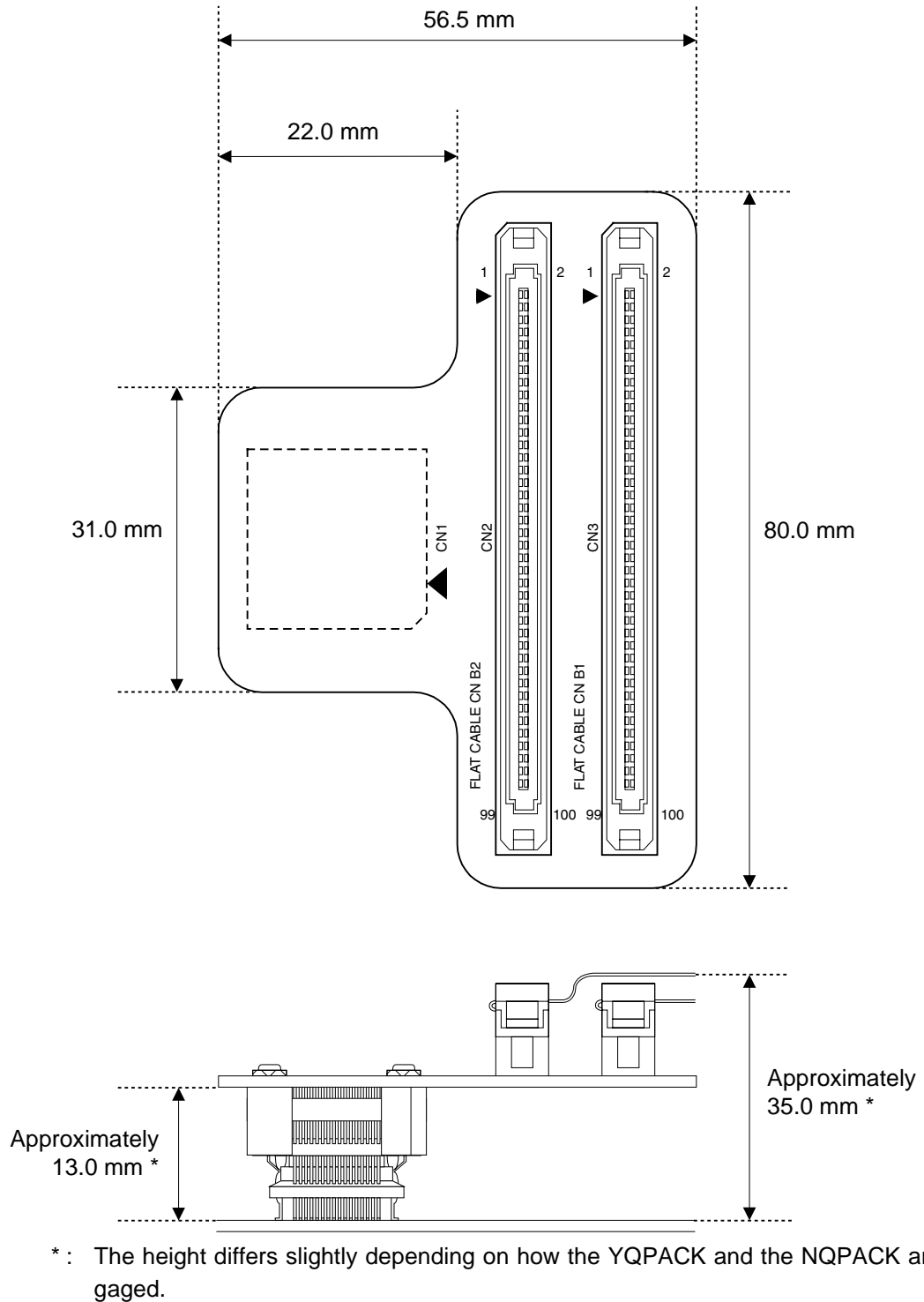

Figure 1 Header board dimensions

## ■ MCU footprint design notes

Figure 2 shows the recommended dimensions of the NQPACK footprint mounted on the PC board of the user system.

The PC board of the user system must be designed with due consideration given to this footprint as well as to the mass production MCU.

For more information, contact the Tokyo Eletech Corporation.

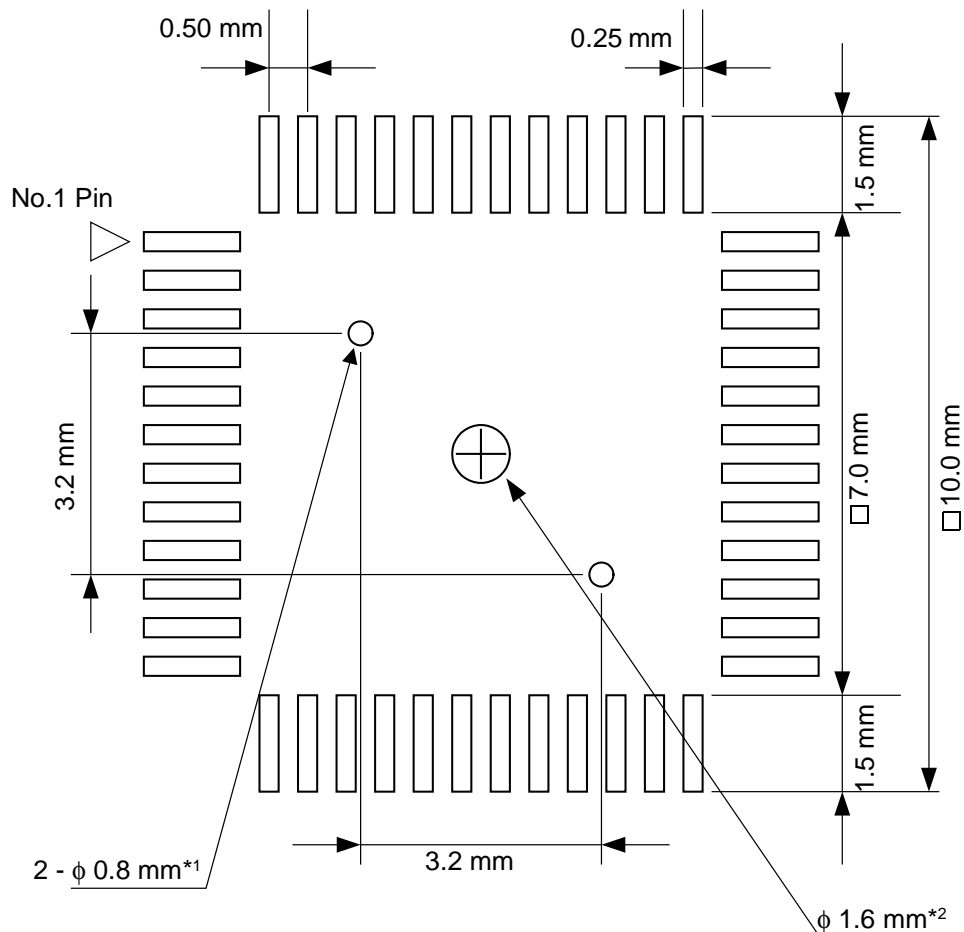

\*1 : It is a position of hole ( $\phi 0.8$ ) for the guide pin to fit position when NQPACK is mounted. When the guide pin is not used, it is not necessary to puncture it.

\*2 : It is a fixation of screw hole ( $\phi 1.6$ ) for IC socket made when NQPACK048SD -SL (Tokyo Eletech Corporation, sold separately) is mounted. When the NQPACK048SD-SL is not used, it is not necessary.

Figure 2 Recommended dimensions of the footprint for mounting the NQPACK

## 4. Procedure for Connecting the User System

Before using the LQFP-48P probe header, mount the supplied NQPACK on the user system. The header board is used combining the adapter board. Moreover, connection of a header board and an adapter board is two flat cables (a standard or Long) appended to the emulator main part. Please use it.

Refer to the hardware manuals of the emulator or the adapter board about the way to connect.

### ■ Connecting

1. To connect the header board to the user system, match the index mark (▲) on the NQPACK mounted on the user system with the index mark (▲) on the header board and then insert it (See Figure 3) . The pin of YQPACK is thin and easy to bent. Insert NQPACK after confirm that the pin of YQPACK is not bent.

2. Insert each screw for securing header board in each of the four drilled holes on the header board (See Figure 4).

To tighten the screws, use the special screwdriver supplied with the NQPACK to finally tighten the four screws in sequence. Please tighten a screw to a diagonal by equal power using a special screwdriver. Tightening the screws too tight might result in a defective contact.

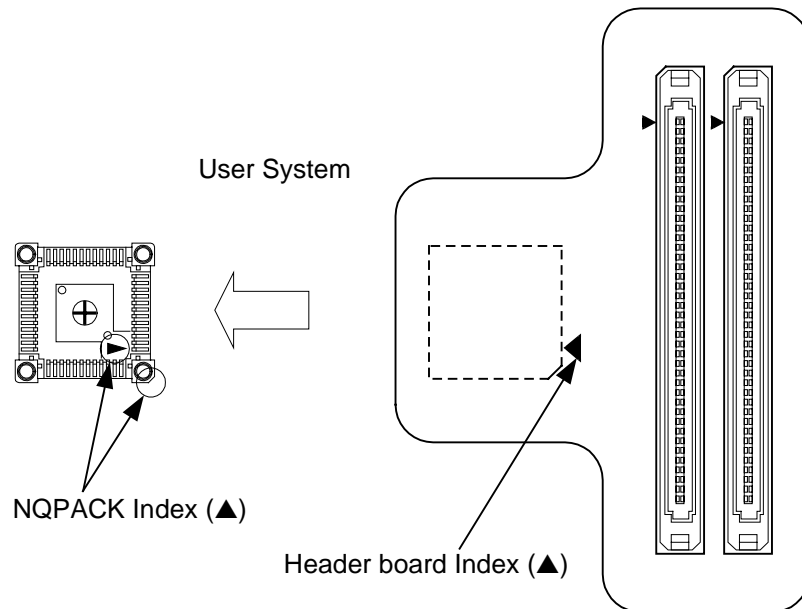

Figure 3 Index Position

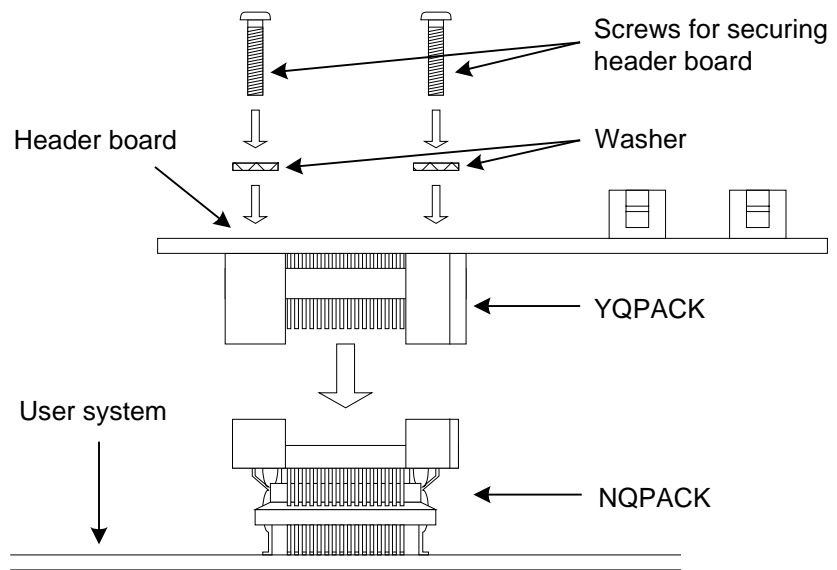

Figure 4 Header board connection

■ **Disconnection**

To disconnect the header board from the user system, remove all four screws, and then pull the header board straight out of the socket



## 5. Mounting Mass Production MCUs

To mount a mass production MCU on the user system, use the supplied HQPACK (See Figure 5).

### ■ Mounting

1. To mount a mass production MCU on the user system, match the index mark (▲) on the NQPACK mounted on the user system with the index mark (●) on the mass production MCU.
2. Confirm that the mass production MCU is correctly mounted on the NQPACK. Next, insert the HQPACK into a NQPACK.  
The pin of HQPACK is thin and easy to bent. Insert NQPACK after confirm that the pin of HQPACK is not bent.
3. Insert each screw for securing HQPACK in each of the four drilled holes on the HQPACK (See Figure 5).

To tighten the screws, use the special screwdriver supplied with the NQPACK to finally tighten the four screws in sequence. Please tighten a screw to a diagonal by equal power using a special screwdriver. Tightening the screws too tight might result in a defective contact.

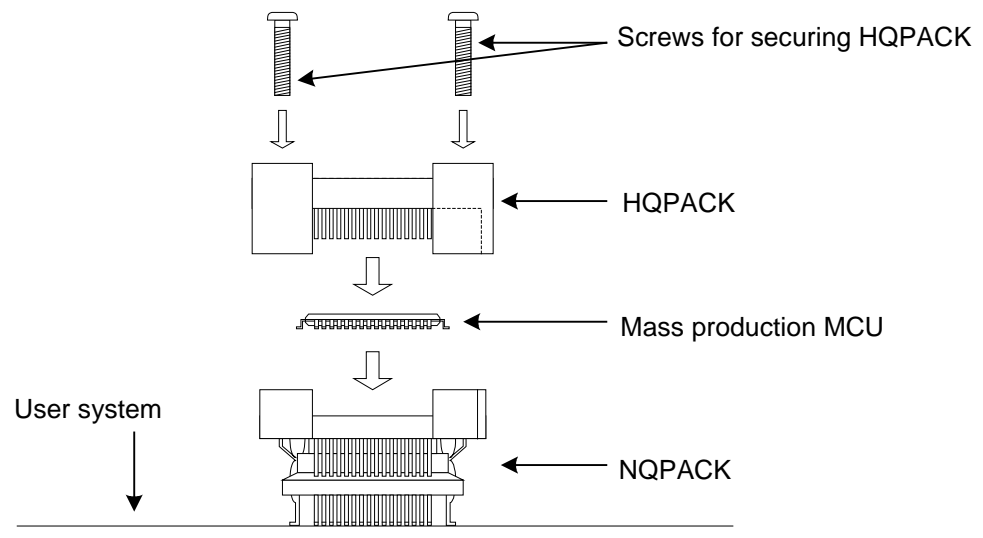

Figure 5 Mounting a mass production MCU

### ■ Disconnection

To remove the HQPACK, remove all four screws, and pull out the HQPACK vertically.

## 6. Connector Pin Assignment

The signal of Evaluation MCU with which it was carried on the adapter board is connected to YQ-PACK(the same assignments as production MCU) via the flat cable connector(B1,B2) on a header board.

Connection of a header board and an adapter board is two flat cables (a standard or Long) appended to the emulator main part. Please use it.

Please check the hardware manual of an emulator or an adapter board about reference of the connection method.

For details on the production MCU's pin information, refer to the datasheet or hardware manual for the relevant MCU.

### ■ Pin Assignment

Tables 1 and 2 list the pin assignments among the flat cable connector, the evaluation MCU on the adapter board, and the production MCU.

For details on the names of signal conductors of the evaluation MCU, refer to the hardware manual for the emulator or adapter board.

Comments in the tables are given below.

- \*1 : Connected to the main power supply (Vcc) of the production MCU. The connection pin number is 24.
- \*2 : Connected to the ground (Vss) of the production MCU. The connection pin number is 25.
- \*3 : Mass production MCU pin(pin number 16): The evaluation MCU pin number is connected to 104 and 252.
- \*4 : Mass production MCU pin(pin number 17): The evaluation MCU pin number is connected to 32 and 71.
- \*5 : Mass production MCU pin(pin number 18): The evaluation MCU pin number is connected to 138 and 225.
- \*6 : Mass production MCU pin(pin number 19): The evaluation MCU pin number is connected to 251 and 274.
- \*7 : Mass production MCU pin(pin number 46): The evaluation MCU pin number is connected to 93, 101 and 267.
- \*8 : Mass production MCU pin(pin number 48): The evaluation MCU pin number is connected to 206 and 258.
- : Unconnected pin (left open).

Table 1 Pin assignment of the flat cable connector B1

| Connector Pin Numbers | Evaluation MCU Pin Numbers | Production MCU Pin Numbers | Connector Pin Numbers | Evaluation MCU Pin Numbers | Production MCU Pin Numbers |
|-----------------------|----------------------------|----------------------------|-----------------------|----------------------------|----------------------------|
| 100                   | *2                         | 25                         | 99                    | *2                         | 25                         |
| 98                    |                            |                            | 97                    | 80                         | 9                          |
| 96                    | 208                        | 10                         | 95                    | 148                        | 8                          |
| 94                    | 259                        | 7                          | 93                    | *2                         | 25                         |
| 92                    | 79                         | 6                          | 91                    | 207                        | 5                          |
| 90                    | 147                        | 4                          | 89                    | 258 *8                     | 48                         |
| 88                    | 78                         | 3                          | 87                    | 206 *8                     |                            |
| 86                    | *2                         | 25                         | 85                    | 77                         | 1                          |
| 84                    | 146                        | 2                          | 83                    | 160                        | —                          |
| 82                    | 223                        | —                          | 81                    | *2                         | 25                         |
| 80                    | 26                         | —                          | 79                    | 268                        | —                          |
| 78                    | 94                         | —                          | 77                    | 269                        | —                          |
| 76                    | 219                        | —                          | 75                    | 95                         | —                          |
| 74                    | *2                         | 25                         | 73                    | 33                         | —                          |
| 72                    | *1                         | 24                         | 71                    | 169                        | —                          |
| 70                    | 226                        | —                          | 69                    | *2                         | 25                         |
| 68                    | 275                        | —                          | 67                    | 34                         | —                          |
| 66                    | 105                        | —                          | 65                    | 167                        | —                          |
| 64                    | 224                        | —                          | 63                    | 35                         | —                          |
| 62                    | *2                         | 25                         | 61                    | 225 *5                     | 18                         |
| 60                    | 274 *6                     | 19                         | 59                    | 32 *4                      | 17                         |
| 58                    | 104 *3                     | 16                         | 57                    | *2                         | 25                         |
| 56                    | 170                        | 15                         | 55                    | 106                        | 14                         |
| 54                    | 227                        | 26                         | 53                    | 163 *1                     | 24                         |
| 52                    | *2                         | 25                         | 51                    | 162                        | —                          |
| 50                    |                            |                            | 49                    | 96                         | —                          |
| 48                    | 220                        | —                          | 47                    | 270                        | —                          |
| 46                    | 100 *2                     | 25                         | 45                    | *2                         | 25                         |
| 44                    | 97                         | 38                         | 43                    | 221                        | 39                         |
| 42                    | 164                        | 37                         | 41                    | 273                        | —                          |
| 40                    | 98                         | 43                         | 39                    | 271                        | 42                         |
| 38                    | *2                         | 25                         | 37                    | 222                        | —                          |
| 36                    | 23                         | 44                         | 35                    | 99                         | 11                         |
| 34                    | 165                        | —                          | 33                    | *2                         | 25                         |
| 32                    | 276                        | 13                         | 31                    | 107                        | 12                         |
| 30                    | 108                        | —                          | 29                    | 277                        | —                          |
| 28                    | 172                        | —                          | 27                    | 109                        | 45                         |
| 26                    | *2                         | 25                         | 25                    | 173                        | 41                         |
| 24                    | 229                        | 40                         | 23                    | 228 *1                     | 24                         |
| 22                    | 130                        | —                          | 21                    | *2                         | 25                         |
| 20                    | 292                        | —                          | 19                    | 193                        | —                          |
| 18                    | 131                        | —                          | 17                    | 194                        | —                          |
| 16                    | 247                        | —                          | 15                    | 132                        | —                          |
| 14                    | *2                         | 25                         | 13                    | *2                         | 25                         |
| 12                    | 293                        | —                          | 11                    | 61                         | 29                         |
| 10                    | 248                        | 30                         | 9                     | *2                         | 25                         |
| 8                     | 133                        | 31                         | 7                     | 195                        | 32                         |
| 6                     | 62                         | 33                         | 5                     | 63                         | 35                         |
| 4                     | 134                        | 34                         | 3                     | 294                        | 36                         |
| 2                     | *2                         | 25                         | 1                     | *2                         | 25                         |

Table 2 Pin assignment of the flat cable connector B2

| Connector Pin Numbers | Evaluation MCU Pin Numbers | Production MCU Pin Numbers | Connector Pin Numbers | Evaluation MCU Pin Numbers | Production MCU Pin Numbers |
|-----------------------|----------------------------|----------------------------|-----------------------|----------------------------|----------------------------|
| 100                   | —                          | —                          | 99                    | *2                         | 25                         |
| 98                    | —                          | —                          | 97                    | 159                        | —                          |
| 96                    | *2                         | 25                         | 95                    | 217                        | 47                         |
| 94                    | 267 *7                     | 46                         | 93                    | *2                         | 25                         |
| 92                    | 149                        | —                          | 91                    | 81                         | —                          |
| 90                    | 260                        | —                          | 89                    | 82                         | —                          |
| 88                    | 209                        | —                          | 87                    | 83                         | —                          |
| 86                    | *2                         | 25                         | 85                    | 87                         | —                          |
| 84                    | 218                        | —                          | 83                    | 212                        | —                          |
| 82                    | 263                        | —                          | 81                    | *2                         | 25                         |
| 80                    | 153                        | —                          | 79                    | 86                         | —                          |
| 78                    | 8                          | —                          | 77                    | 150                        | —                          |
| 76                    | *1                         | 24                         | 75                    | 84                         | —                          |
| 74                    | *2                         | 25                         | 73                    | 272                        | —                          |
| 72                    | 5                          | —                          | 71                    | 168                        | —                          |
| 70                    | 103                        | —                          | 69                    | *2                         | 25                         |
| 68                    | 166                        | —                          | 67                    | 7                          | —                          |
| 66                    | *2                         | 25                         | 65                    | 210                        | —                          |
| 64                    | 151                        | —                          | 63                    | 261                        | —                          |
| 62                    | *2                         | 25                         | 61                    | 158                        | —                          |
| 60                    | 6                          | —                          | 59                    | 216                        | —                          |
| 58                    | 92                         | —                          | 57                    | *2                         | 25                         |
| 56                    | 266                        | —                          | 55                    | 157                        | —                          |
| 54                    | 91                         | —                          | 53                    | 156                        | —                          |
| 52                    | 215                        | —                          | 51                    | 155                        | —                          |
| 50                    | *2                         | 25                         | 49                    | 88                         | —                          |
| 48                    | 16                         | —                          | 47                    | 15                         | —                          |
| 46                    | 264                        | —                          | 45                    | *2                         | 25                         |
| 44                    | 213                        | —                          | 43                    | 154                        | —                          |
| 42                    | 14                         | —                          | 41                    | 255                        | —                          |
| 40                    | 203                        | —                          | 39                    | 143                        | —                          |
| 38                    | *2                         | 25                         | 37                    | 202                        | —                          |
| 36                    | 299                        | —                          | 35                    | 142                        | —                          |
| 34                    | 201                        | —                          | 33                    | *2                         | 25                         |
| 32                    | 141                        | —                          | 31                    | 101 *7                     | 46                         |
| 30                    | 110                        | 20                         | 29                    | 230                        | 22                         |
| 28                    | 278                        | 21                         | 27                    | 262                        | 23                         |
| 26                    | *2                         | 25                         | 25                    | 140                        | 27                         |
| 24                    |                            |                            | 23                    | 200                        | 28                         |
| 22                    | *1                         | 24                         | 21                    | *2                         | 25                         |
| 20                    | 252 *3                     | 16                         | 19                    | 199                        | —                          |
| 18                    | 71 *4                      | 17                         | 17                    | 70                         | —                          |
| 16                    | 138 *5                     | 18                         | 15                    | 251 *6                     | 19                         |
| 14                    | *2                         | 25                         | 13                    | 198                        | —                          |
| 12                    | 296                        | —                          | 11                    | 137                        | —                          |
| 10                    | 136                        | —                          | 9                     | *2                         | 25                         |
| 8                     | 197                        | —                          | 7                     | 295                        | —                          |
| 6                     | 250                        | —                          | 5                     | 64                         | —                          |
| 4                     | 135                        | —                          | 3                     | 196                        | —                          |
| 2                     | *2                         | 25                         | 1                     | *2                         | 25                         |

SS01-71046-1E

---

**FUJITSU SEMICONDUCTOR • SUPPORT SYSTEM**

F<sup>2</sup>MC-16 Family EMULATOR  
LQFP-48P PROBE HEADER  
MB2147-521  
OPERATION MANUAL

---

March 2005 the first edition

Published **FUJITSU LIMITED** Electronic Devices

Edited Business Promotion Dept.

---

FUJITSU