

Features

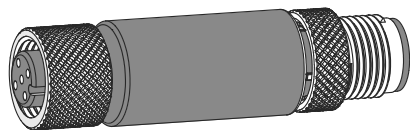

- Compact converter that connects to a Modbus® device and outputs the value as a pulsed signal, either PFM or PWM
- Modbus registers are used to define PWM and PFM setting
- Outputs can be independently configured as NPN or PNP
- Rugged overmolded design meets IP65, IP67, and IP68
- Connects directly to a sensor or anywhere in-line for ease of use

S15CM Models

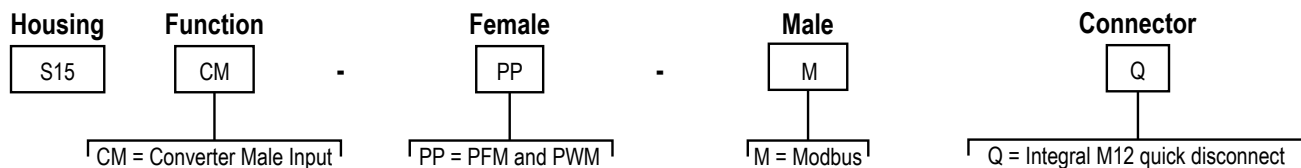

Configuration Instructions

Sensor Configuration Software

The Sensor Configuration Software offers an easy way to manage converter Modbus settings, retrieve data, and visually show converter data. The Sensor Configuration Software runs on any Windows machine and uses an adapter cable (BWA-UCT-900, p/n 19970) to connect the converter to the computer.

Download the most recent version of the Sensor Configuration Software from the Banner Engineering website: https://info.bannerengineering.com/cs/groups/public/documents/software/b_3128586.exe.

Modbus Configuration

Pin 4 Port Configuration

Modbus Register Address	Description	I/O Range	Comments	Default	Access	Notes
40200	Pin 4 IO Selection	4..5	4 = NPN output push/pull 5 = PNP output push/pull	4	RW	—
40201	Pin 4 Mode	0, 7, 8	0 = Disabled 7 = PWM 8 = PFM	7	RW	PFM 50% duty cycle
40202	Pin 4 PWM Base Freq	200..4000	PWM Base Frequency (Hz)	500	RW	PWM base freq = 200 (Hz)..4000 (Hz)
40203	Pin 4 Percentage	0..100	PWM Percentage	100	RW	PWM % = 0..100 If PWM % > 100, = 100
40204	Pin 4 PFM Frequency	50..50,000	PFM Frequency	50,000	RW	PFM 50 (Hz)..50K (Hz)

Pin 2 Port Configuration

Modbus Register Address	Description	I/O Range	Comments	Default	Access	Notes
40300	Pin 2 IO Selection	4..5	4 = NPN output push/pull 5 = PNP output push/pull	5	RW	—
40301	Pin 2 Mode	0, 7, 8	0 = Disabled 7 = PWM 8 = PFM	8	RW	PFM 50% duty cycle
40302	Pin 2 PWM Base Freq	200..4000	PWM Base Frequency (Hz)	500	RW	PWM base freq = 200 (Hz)..4000 (Hz)
40303	Pin 2 Percentage	0..100	PWM Percentage	100	RW	PWM % = 0..100 If PWM % > 100, = 100

Continued on page 2



Continued from page 1

Modbus Register Address	Description	I/O Range	Comments	Default	Access	Notes
40304	Pin 2 PFM Frequency	50..50,000	PFM Frequency	50,000	RW	PFM 50 (Hz)..50K (Hz)

Modbus Configuration

Modbus Register Address	Description	I/O Range	Comments	Default	Access
40601	Baud Rate	0 = 9.6k 1 = 19.2k 2 = 38.4k	0 = 9600 1 = 19200 2 = 38400	1	RW
40602	Parity	0 = None 1 = Odd 2 = Even	0 = None 1 = Odd 2 = Even	0	RW
40603	Address	1-254	-	1	RW
40604	Reserved (cannot be read or written)	None	-	-	RW
40605	Restore Factory Configuration	0 = No Operation, 1 = Restore	-	-	WO

Device Information

Modbus Register Address ⁽¹⁾	Description	I/O Range	Comments	Default	Access	Notes
40606-40615	Banner Name	0..65535	-	Banner Engineering	RO	(9 words/18 characters)
40616-40631	Product Name	0..65535	-	S15CM-PP-MQ	RO	(16 words/32 characters)
40632	Item H	0..65535	812607 split into two 16-bit registers	12	RO	Banner Item Number
40633	Item L	0..65535		26175	RO	-
40634	Serial Number H	0..65535	-	-	RO	Serial Number is split into four 16-bit registers
40635	Serial Number	0..65535	-	-	RO	
40636	Serial Number	0..65535	-	-	RO	
40637	Serial Number L	0..65535	-	-	RO	
40644-40659	User Define Tag	0..65535	User writable space	More Sensors. More Solutions.	RW	(16 words/32 characters)

Wiring Diagrams

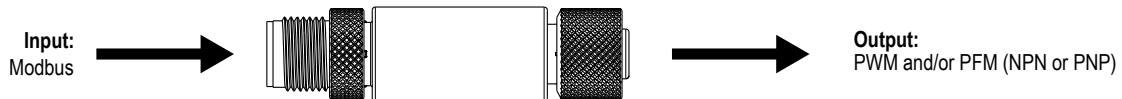

Male	Female	Pin	Wire Color
		1	Brown
		2	White
		3	Blue
		4	Black
		5 (male only)	Gray (male only)

⁽¹⁾ Registers are big endian.

Connecting Devices with Discrete Inputs/Outputs

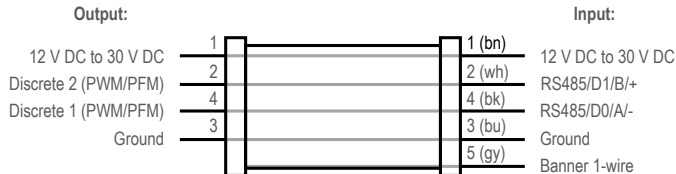

Status Indicators

Power LED Indicator (Green)

- Solid Green = Power On
- Off = Power Off

Modbus Communication LED Indicator (Amber)

- Flashing Amber (4 Hz) = Modbus communications are active
- Solid Amber for 2 Seconds to Off = Modbus communications are lost after connection
- Solid Amber for 2 Seconds to Flashing Amber (4 Hz) = Modbus communications momentarily lost, but communication reestablished
- Solid Amber = Modbus communications are intermittent, or communications error occurs more frequently than once every 2 seconds
- Off = Modbus communications are not present

S15CM Specifications

Supply Voltage

12 V DC to 30 V DC at 50 mA maximum

Power Pass-Through Current

4 A maximum

Supply Protection Circuitry

Protected against reverse polarity and transient voltages

Discrete Output Ratings

OFF-state leakage current:

NPN: 300 µA

PNP: 10 µA

ON-state saturation voltage:

NPN: 2 V at 50 mA

PNP: 2 V at 50 mA

Indicators

Green: Power

Amber: Modbus communications

Connections

Integral male/female 4-pin M12 quick disconnect

Construction

Coupling Material: Nickel-plated brass

Connector Body: PVC translucent black

Vibration and Mechanical Shock

Meets IEC 60068-2-6 requirements (Vibration: 10 Hz to 55 Hz, 0.5 mm amplitude, 5 minutes sweep, 30 minutes dwell)

Meets IEC 60068-2-27 requirements (Shock: 15G 11 ms duration, half sine wave)

Environmental Rating

IP65, IP67, IP68

NEMA/UL Type 1

Operating Conditions

Temperature: -40 °C to +70 °C (-40 °F to +158 °F)

90% at +70 °C maximum relative humidity (non-condensing)

Storage Temperature: -40 °C to +80 °C (-40 °F to +176 °F)

Advanced Capabilities



Continued from page 2

Supply Wiring (AWG)	Required Overcurrent Protection (A)	Supply Wiring (AWG)	Required Overcurrent Protection (A)
22	3.0	28	0.8
24	1.0	30	0.5

Required Overcurrent Protection



WARNING: Electrical connections must be made by qualified personnel in accordance with local and national electrical codes and regulations.

Overcurrent protection is required to be provided by end product application per the supplied table.

Overcurrent protection may be provided with external fusing or via Current Limiting, Class 2 Power Supply.

Supply wiring leads < 24 AWG shall not be spliced.

For additional product support, go to www.bannerengineering.com.

Supply Wiring (AWG)	Required Overcurrent Protection (A)	Supply Wiring (AWG)	Required Overcurrent Protection (A)
20	5.0	26	1.0

Continued on page 4

Certifications



Banner Engineering BV
Park Lane, Culliganlaan 2F bus 3
1831 Diegem, BELGIUM



Turck Banner LTD Blenheim House
Blenheim Court
Wickford, Essex SS11 8YT
GREAT BRITAIN



PROGRAMMABLE
CONTROLLER
E316212

FCC Part 15 Class B

This equipment has been tested and found to comply with the limits for a Class B digital device, pursuant to part 15 of the FCC Rules. These limits are designed to provide reasonable protection against harmful interference in a residential installation. This equipment generates, uses and can radiate radio frequency energy and, if not installed and used in accordance with the instructions, may cause harmful interference to radio communications. However, there is no guarantee that interference will not occur in a particular installation. If this equipment does cause harmful interference to radio or television reception, which can be determined by turning the equipment off and on, the user is encouraged to try to correct the interference by one or more of the following measures:

- Reorient or relocate the receiving antenna.
- Increase the separation between the equipment and receiver.
- Connect the equipment into an outlet on a circuit different from that to which the receiver is connected.
- Consult the dealer or an experienced radio/TV technician for help.

Industry Canada Statement for Intentional Radiators

This device contains licence-exempt transmitters(s)/receiver(s) that comply with Innovation, Science and Economic Development Canada's licence-exempt RSS(s). Operation is subject to the following two conditions:

1. This device may not cause interference.
2. This device must accept any interference, including interference that may cause undesired operation of the device.

Cet appareil contient des émetteurs/récepteurs exemptés de licence conformes à la norme Innovation, Sciences, et Développement économique Canada. L'exploitation est autorisée aux deux conditions suivantes:

1. L'appareil ne doit pas produire de brouillage.
2. L'utilisateur de l'appareil doit accepter tout brouillage radioélectrique subi, même si le brouillage est susceptible d'en compromettre le fonctionnement.

Dimensions

All measurements are listed in millimeters [inches], unless noted otherwise.

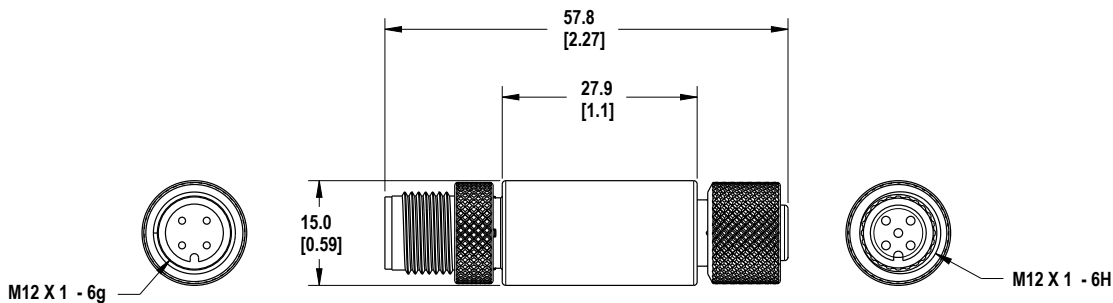

Accessories

Cordsets

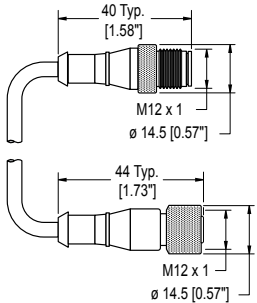
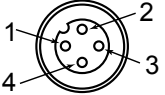
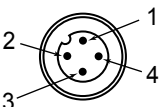
4-Pin Threaded M12 Cordsets—Double Ended				
Model	Length	Style	Dimensions	Pinout
MQDEC-401SS	0.31 m (1 ft)	Male Straight/Female Straight		Female
MQDEC-403SS	0.91 m (2.99 ft)			
MQDEC-406SS	1.83 m (6 ft)			
MQDEC-412SS	3.66 m (12 ft)			
MQDEC-420SS	6.10 m (20 ft)			
MQDEC-430SS	9.14 m (30.2 ft)			
MQDEC-450SS	15.2 m (49.9 ft)	Male		

- 1 = Brown
- 2 = White
- 3 = Blue
- 4 = Black

Banner Engineering Corp Limited Warranty

Banner Engineering Corp. warrants its products to be free from defects in material and workmanship for one year following the date of shipment. Banner Engineering Corp. will repair or replace, free of charge, any product of its manufacture which, at the time it is returned to the factory, is found to have been defective during the warranty period. This warranty does not cover damage or liability for misuse, abuse, or the improper application or installation of the Banner product.

THIS LIMITED WARRANTY IS EXCLUSIVE AND IN LIEU OF ALL OTHER WARRANTIES WHETHER EXPRESS OR IMPLIED (INCLUDING, WITHOUT LIMITATION, ANY WARRANTY OF MERCHANTABILITY OR FITNESS FOR A PARTICULAR PURPOSE), AND WHETHER ARISING UNDER COURSE OF PERFORMANCE, COURSE OF DEALING OR TRADE USAGE.

This Warranty is exclusive and limited to repair or, at the discretion of Banner Engineering Corp., replacement. **IN NO EVENT SHALL BANNER ENGINEERING CORP. BE LIABLE TO BUYER OR ANY OTHER PERSON OR ENTITY FOR ANY EXTRA COSTS, EXPENSES, LOSSES, LOSS OF PROFITS, OR ANY INCIDENTAL, CONSEQUENTIAL OR SPECIAL DAMAGES RESULTING FROM ANY PRODUCT DEFECT OR FROM THE USE OR INABILITY TO USE THE PRODUCT, WHETHER ARISING IN CONTRACT OR WARRANTY, STATUTE, TORT, STRICT LIABILITY, NEGLIGENCE, OR OTHERWISE.**

Banner Engineering Corp. reserves the right to change, modify or improve the design of the product without assuming any obligations or liabilities relating to any product previously manufactured by Banner Engineering Corp. Any misuse, abuse, or improper application or installation of this product or use of the product for personal protection applications when the product is identified as not intended for such purposes will void the product warranty. Any modifications to this product without prior express approval by Banner Engineering Corp will void the product warranties. All specifications published in this document are subject to change; Banner reserves the right to modify product specifications or update documentation at any time. Specifications and product information in English supersede that which is provided in any other language. For the most recent version of any documentation, refer to: www.bannerengineering.com.

For patent information, see www.bannerengineering.com/patents.

Document title: S15CM Modbus® to PWM and PFM Converter
 Part number: 224486
 Revision: C
 Original Instructions
 © Banner Engineering Corp. All rights reserved.

