



## ABSTRACT

This document is provided with the MCT8316A customer evaluation module (EVM) as a supplement to the MCT8316A data sheet ([MCT8316A Three-Phase Sensorless Trapezoidal Control BLDC Motor Driver](#)). This User's Guide details the hardware implementation of the EVM and how to setup and power the board.

---

## Table of Contents

<b>1 Cautions and Warnings</b> .....	2
<b>2 Introduction</b> .....	3
<b>3 Quick Start Guide</b> .....	4
<b>4 Hardware and Software Overview</b> .....	5
4.1 Hardware Connections Overview – MCT8316AEVM.....	5
4.2 Connection Details.....	5
4.3 MSP430FR2355 Microcontroller & User Interface.....	7
4.4 LED Lights.....	8
4.5 User-Configurable Settings.....	9
<b>5 Hardware Setup</b> .....	11
<b>6 MCT8316A GUI Application</b> .....	12
6.1 Running the GUI.....	12
6.2 Offline Installer.....	12
<b>7 MSP430FR2355 Interface Firmware</b> .....	14
7.1 Downloading Code Composer Studio and Importing MSP430FR2355 Interface Firmware Code.....	14
7.2 Using the eZ-FET to Program the MSP430FR2355.....	14
<b>8 Schematics</b> .....	16
8.1 Main Supply and Pi Filter.....	16
8.2 Connectors and Interface.....	16
8.3 USB to UART.....	17
8.4 MCU Programming and Debug.....	17
8.5 MSP430FR2355 MCU.....	18
8.6 MCT8316A 3-Phase Sensorless Trapezoidal Control Integrated Driver.....	18
8.7 Buck Regulator.....	19
8.8 Status LEDs.....	20
8.9 Switches and Speed Input.....	20
<b>9 Revision History</b> .....	20

## Trademarks

LaunchPad™ are trademarks of Texas Instruments.  
All trademarks are the property of their respective owners.

## 1 Cautions and Warnings

Observe the following cautions and warnings as printed on the EVM board.

**HOT SURFACE:**



**Caution Hot Surface! Contact may cause burns. Do not touch. Please take the proper precautions when operating.**

## 2 Introduction

The MCT8316A is a 4.5-V to 35-V, 8-A peak integrated three-phase gate driver IC with high speed sensorless trapezoidal control for motor drive applications. It provides three accurately trimmed and temperature compensated half-bridge MOSFETS, gate drivers, charge pump, current sense amplifier, linear regulator for the external load and adjustable buck regulator. The I2C interface variant (MCT8316A) also provides a standard I2C interface for configuring the various device settings and reading fault diagnostic information through an external controller.

The MCT8316AEVM includes an onboard FTDI chip to convert USB communication from the micro-USB connector into UART and an onboard MSP430FR2355 MCU to interface with the MCT8316A. It can also provide SPI communication for the SPI variant of the MCT8316A device. There are many user-selectable jumpers, resistors, connectors, and test points to evaluate many features of the device and configure device-specific settings.

This document serves as a startup guide to supplement the MCT8316AEVM. It is intended for engineers to design, implement, and validate reference hardware for the MCT8316A device.

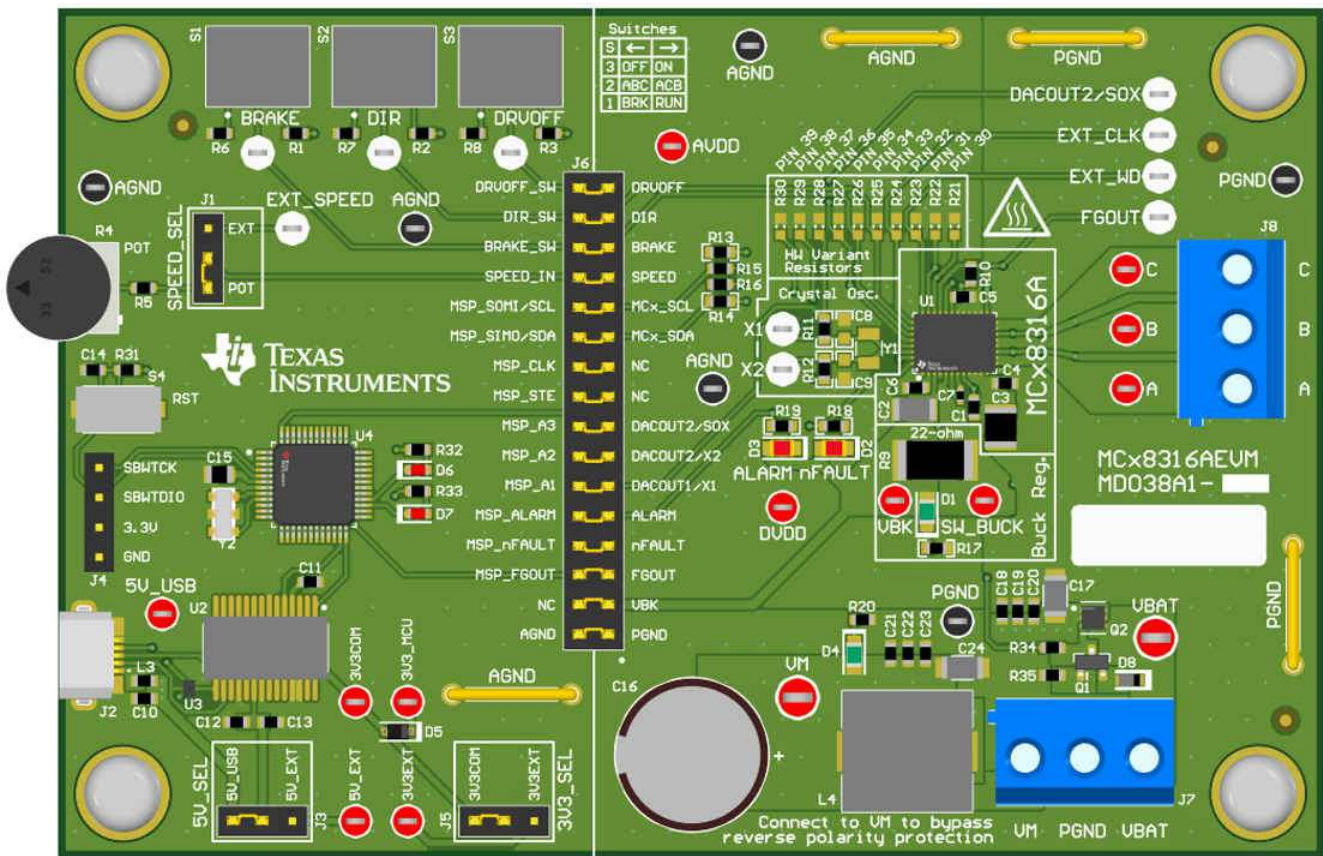

Figure 2-1. MCT8316AEVM Printed Circuit Board (PCB - Top View)

### 3 Quick Start Guide

The MCT8316AEVM requires a power supply source, which has a recommended operating range from a 4.5-V to 35-V. To setup and power the EVM, follow the sequence below:

1. Connect motor phases to A, B, C on connector J8.
2. Do not turn on the power supply yet. Connect motor supply to VBAT/VM and PGND on connector J7.
  - a. To enable reverse polarity protection and Pi filter, connect to VBAT. Note that when connecting to VBAT, VM will be  $VM - 0.7\text{ V}$  less, due to a diode drop in the reverse-polarity protection circuit.
  - b. To disable reverse-polarity protection and the Pi filter, connect to VM.
3. Select J3 to 5V\_USB and J5 to 3V3COM to power MSP430 from USB power supply.
4. Connect the micro-USB cable into the computer.
5. Turn the potentiometer fully clockwise to set the motor to zero speed upon powerup.
6. Flip the switch S1 to the right to configure BRAKE = RUN, switch S2 to the left to configure DIR = ABC, and switch S3 to the right to configure DRVOFF = ON
7. Turn on the motor power supply.
8. Use the potentiometer R4 to control the speed of the motor and the switches to disable the motor driver, change the direction, or apply a brake to the motor. Optionally, use the GUI (as shown in [Section 6](#)) to monitor real-time speed of the motor, put the MCT8316A into a low-power sleep mode, and read status of the LEDs.

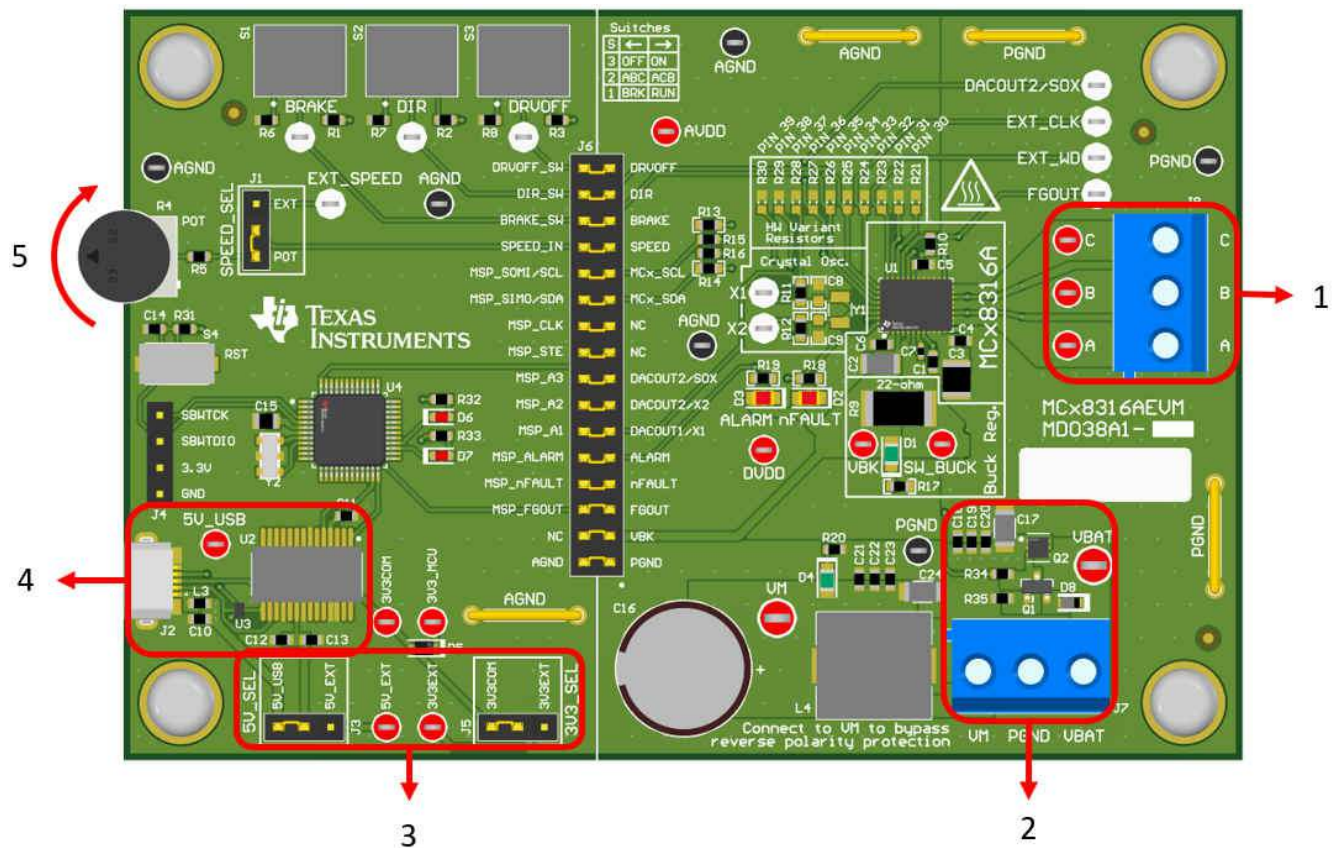

Figure 3-1. Reference for Quick Start Guide



## 4 Hardware and Software Overview

### 4.1 Hardware Connections Overview – MCT8316AEVM

Figure 4-1 shows the major blocks of MCT8316AEVM evaluation module. The MCT8316AEVM is designed for an input supply from 4.5-V to 35-V. The MCT8316A includes three integrated half-bridges and implements a sensorless trapezoidal control algorithm to spin a motor with up to 8-A peak current. It also integrates an adjustable buck regulator.

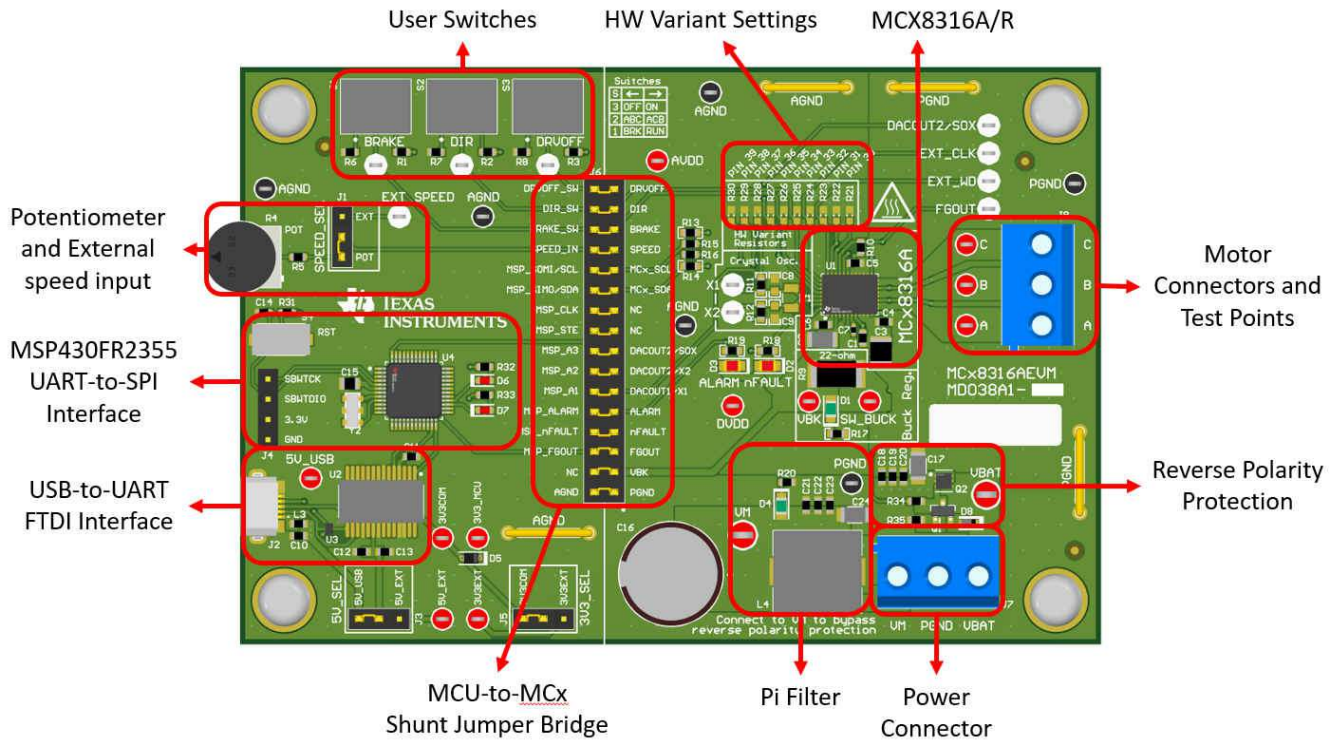

**Figure 4-1. MCT8316AEVM Major Hardware Blocks**

### 4.2 Connection Details

Figure 4-2 shows the connections made to the MCT8316AEVM in order to spin a 3-phase sensorless Brushless-DC motor.

An 4.5-V to 35-V power supply or battery is connected to the VBAT or VM and PGND terminals on connector J7. There is a reverse polarity protection and Pi filter implemented on the VBAT and PGND terminals. To bypass the reverse polarity protection and Pi filter, connect the power supply to the VM terminal or VM test point on the board and PGND.

The three phases of the BLDC motor connect directly to the A, B, and C terminals of the screw terminal connector J8 provided on the MCT8316AEVM.

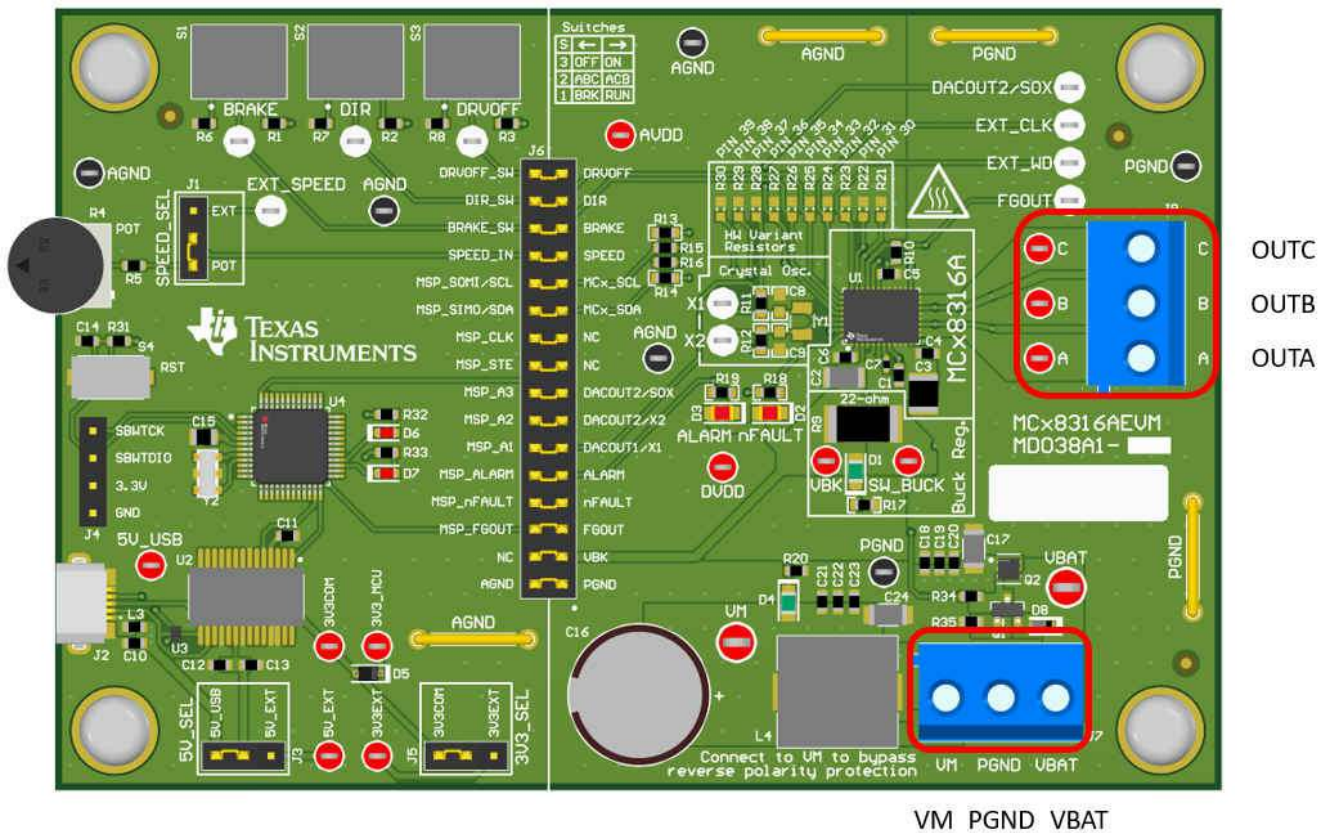

**Figure 4-2. Connections from Motor to MCT8316AEVM**

Figure 4-3 shows where the micro-USB cable is plugged into the MCT8316AEVM to provide communication between evaluation module and GUI. The USB data and 5 V power from the USB is converted into UART data and 3.3 V power to power the MSP430FR2355 microcontroller. The 5 V from the USB power is limited to 500 mA and the 3.3 V from the FTDI chip is limit to 30 mA. If the user wishes to supply more current to these rails, they may use the 5V\_SEL jumper J3 and 3V3\_SEL jumper J5 to connect external power rails.

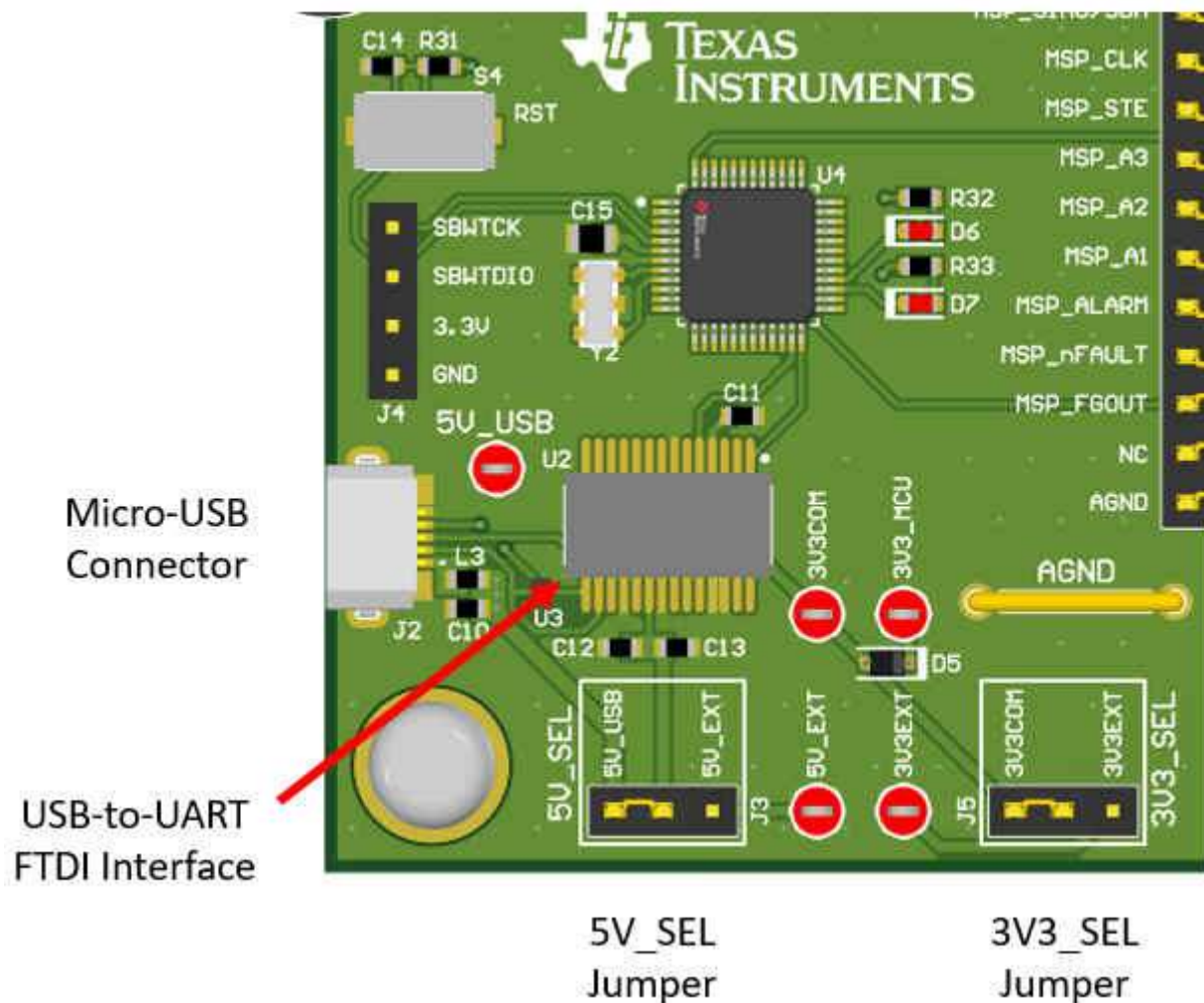

**Figure 4-3. Micro-USB Connector and UART for MCT8316AEVM**

### 4.3 MSP430FR2355 Microcontroller & User Interface

The MCT8316AEVM includes the MSP430FR2355 low-power MCU (as shown in [Figure 4-4](#)) to communicate via I2C with the MCT8316A.

In order to program the MSP430FR2355, an external MSP430 FET programmer must be connected to the Spy-Bi-Wire (SBW) interface connector J4. Many MSP430 LaunchPad™ provide an onboard eZ-FET Debug Probe that can be jumper-wired to the MCT8316AEVM to flash the firmware into the MSP430FR2355 microcontroller.

The user can use the Reset (RST) button at any time to reset and restart the MCU program. Two active-low LEDs, D6 and D7, can be used for debug purposes as well.

Finally, a shunt jumper bridge on the 32-pin connector J6 ties all signals between the microcontroller and MCT8316A. These jumpers can be inserted or removed as needed in order to isolate the microcontroller from the gate driver. This allows for microcontroller signal debugging or using the MCT8316AEVM as a standalone gate driver with an external microcontroller.



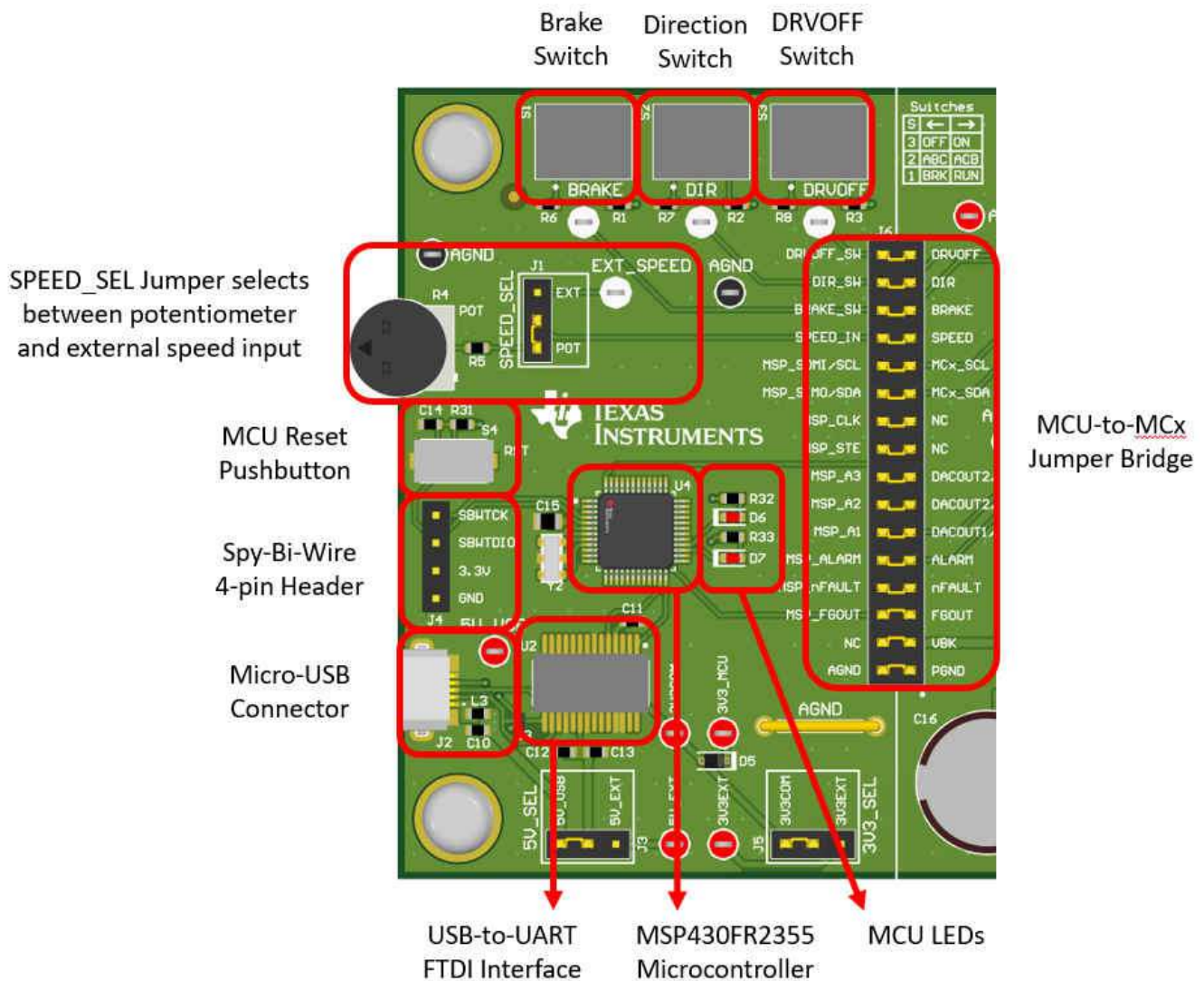

Figure 4-4. MSP430FR2355 MCU and User Interface on MCT8316AEVM

#### 4.4 LED Lights

The MCT8316AEVM has 5 status LEDs implemented that provide the status of power supplies and functionalities of the evaluation module. By default, the VM LED and 3.3 V Buck LEDs will light up when the board is powered and the program has been flashed onto the microcontroller. Table 4-1 shows LED descriptions including those that are on during power up in bold and Figure 4-5 shows the locations of the LEDs.

Table 4-1. Description of MCT8316AEVM LEDs (default in bold after powerup)

Designator	Name	Color	Description
D1	<b>Buck Regulator</b>	<b>Green</b>	<b>Internal buck regulator is voltage output</b>
D2	<b>nFAULT</b>	<b>Red</b>	<b>Lights up when fault condition has occurred on MCT8316A</b>
D3	ALARM	Red	Lights up when alarm condition has occurred on MCT8316A
D4	<b>VM</b>	<b>Green</b>	<b>Motor power is supplied to the board</b>
D5	<b>MSP_LED1</b>	<b>Red</b>	<b>Used for UART or debugging</b>
D6	MSP_LED2	Red	Used for UART or debugging



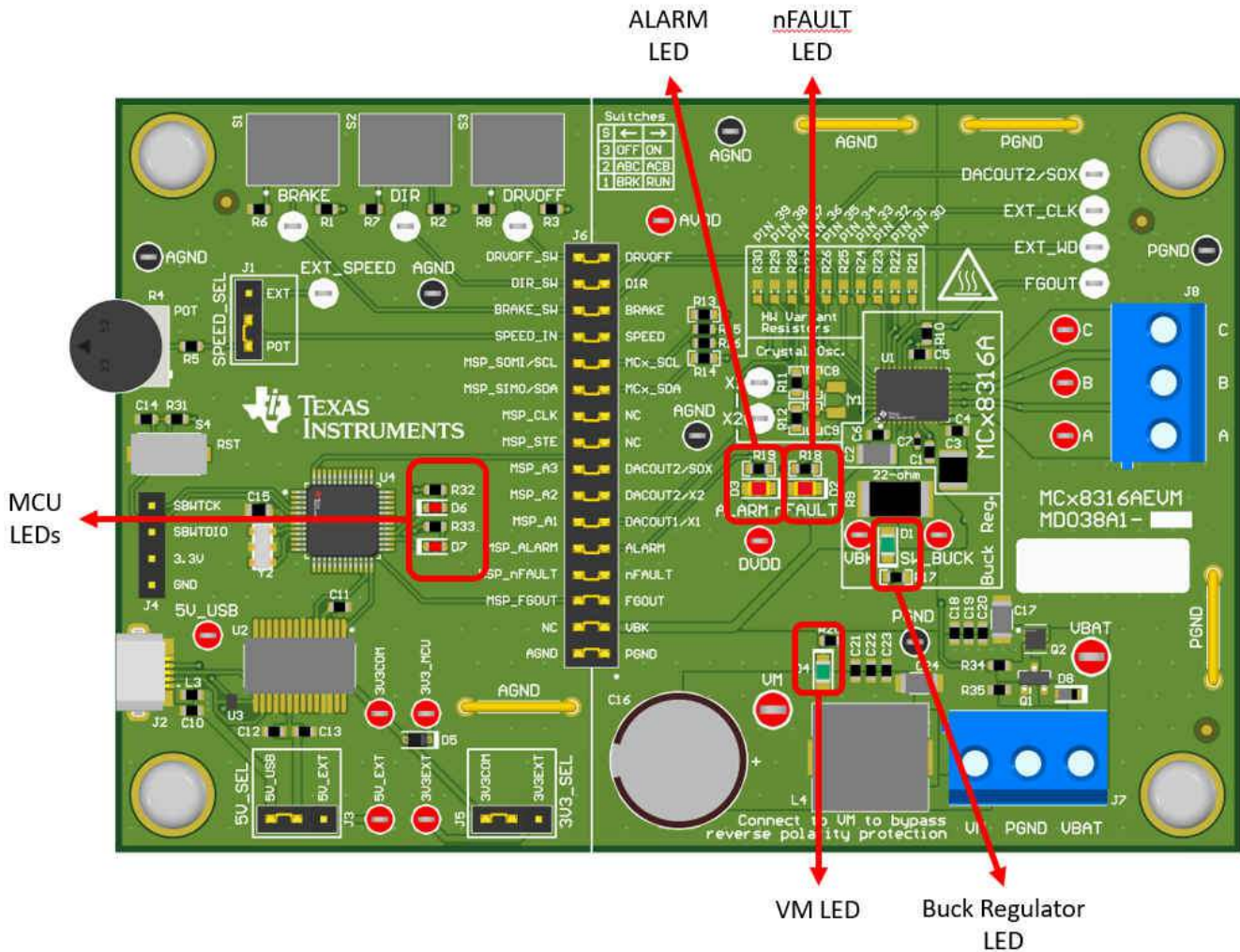

Figure 4-5. MCT8316AEVM LEDs

#### 4.5 User-Configurable Settings

The MCT8316AEVM includes a variety of user-selectable jumpers, switches, and resistors on the entirety of the evaluation board to configure settings. Table 4-2 summarizes all of these configurable settings.

Table 4-2. Description of User-Selectable Settings on MCT8316AEVM (Default in Bold)

Designator	Setting Name	Description	Layer	Position	Function
L1/L2/R9	Buck Regulator mode	User populates L1, L2, or R9 to choose switching component for buck regulator	Top	L1 = 47uH Inductor	Inductor Mode
			Bottom	L2 = 22 μH	Inductor Mode
			Bottom	<b>R1 = 22 Ω</b>	<b>Resistor Mode</b>
J5	3V3_SEL	Select 3.3 V for MCU power	Top	J5 = 3V3EXT	External
				<b>J5 = 3V3COM</b>	<b>From FTDI (30 mA)</b>
J3	5V_SEL	Select 5 V for FTDI power	Top	J3 = 5V_EXT	External
				<b>J3 = 5V_USB</b>	<b>From USB power (500 mA)</b>

**Table 4-2. Description of User-Selectable Settings on MCT8316AEVM (Default in Bold) (continued)**

Designator	Setting Name	Description	Layer	Position	Function
J1	SPEED_SEL	Selects SPEED input source	Top	J1 = EXT	External EXT_SPEED test point
				<b>J1 = POT</b>	<b>From Potentiometer R4</b>
				J1 is removed	Floating
J6	MSP to MCx Shunt jumper bridge	Connects signals from MCU and user switches to MCx8316A when jumpers are inserted	Top	<b>DRVOFF_SW</b>	<b>DRVOFF</b>
				<b>DIR_SW</b>	<b>DIR</b>
				<b>BRAKE_SW</b>	<b>BRAKE</b>
				<b>SPEED_IN</b>	<b>SPEED</b>
				<b>MSP_SOMI/SCL</b>	<b>MCx_SCL</b>
				<b>MSP_SIMO/SDA</b>	<b>MCx_SDA</b>
				<b>MSP_CLK</b>	<b>NC</b>
				<b>MSP_STE</b>	<b>NC</b>
				<b>MSP_A3</b>	<b>DACOUT2/SOX</b>
				<b>MSP_A2</b>	<b>MCX_DACOUT2/X2</b>
				<b>MSP_A1</b>	<b>MCX_DACOUT1/X1</b>
				<b>MSP_ALARM</b>	<b>ALARM</b>
				<b>MSP_nFAULT</b>	<b>nFAULT</b>
				<b>MSP_FGOUT</b>	<b>FGOUT</b>
<b>NC</b>	<b>VBK</b>				
<b>AGND</b>	<b>AGND</b>				
S1	BRAKE	Turns on all low-side MOSFETs	Top	Left	Brake enabled
				<b>Right</b>	<b>Brake disabled</b>
S2	DIR	Controls direction of motor	Top	<b>Left</b>	<b>ABC</b>
				Right	ACB
S3	DRVOFF	Disables gate drivers	Top	Left	MCT8316A disabled
				<b>Right</b>	<b>MCT8316A enabled</b>

## 5 Hardware Setup

The hardware required to run the motor is the MCT8316AEVM, a Micro-USB cable, and a power supply with a DC output from 4.5-V to 35-V. Follow these steps to start up the MCT8316AEVM:

1. Connect the DC power supply to header J7. Connect to VBAT and PGND to apply reverse polarity protection and the pi filter to the EVM. Otherwise, connect to VM and PGND to bypass the reverse polarity protection and pi filter.
2. Apply user configurable jumper settings. See [Section 4.5](#) section for more information.
3. Launch the GUI in GUI Composer.
4. Connect a Micro-USB cable to the MCT8316AEVM and computer.
5. Turn on the power supply and power up the PCB.

If using the MCT8316AEVM with an external microcontroller, remove all shunt jumpers from jumper bridge J6. Connect with external jumpers to the left side of the jumper bridge from the external MCU.



## 6 MCT8316A GUI Application

The MCT8316AEVM includes a USB-UART interface, using a MSP430FR2355 microcontroller, that serves as a communication bridge between a host PC and the MCT8316A device for configuring various device settings and reading fault diagnostic information. A MCT8316A GUI is available to interface with and configure the MCT8316A using this communication interface.

Access the [MCT8316A GUI](#) through the TI Cloud Gallery.

### 6.1 Running the GUI

The MCT8316A GUI can be run directly inside a web browser (supported in Google Chrome and Firefox).

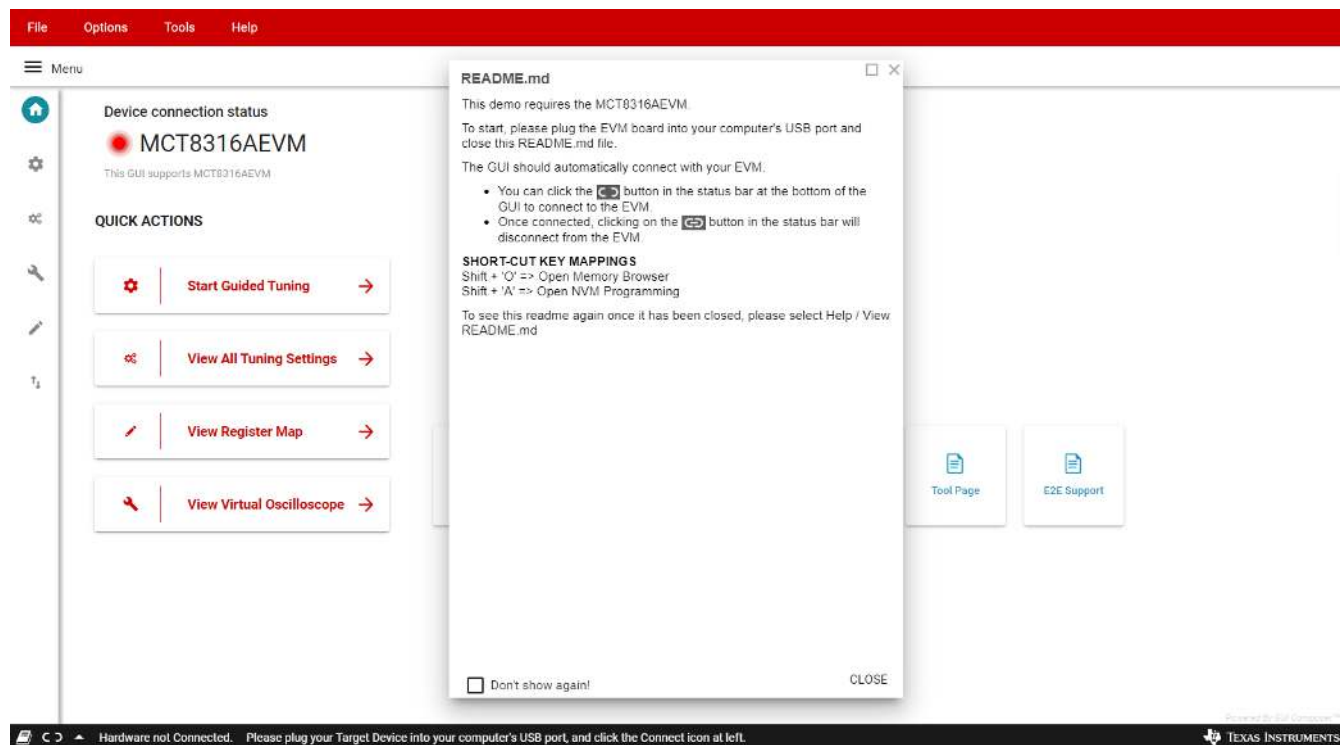

**Figure 6-1. MCT8316A GUI**

Once the GUI is loaded, follow the step-by-step Guided Tuning section of the GUI to configure the device.

### 6.2 Offline Installer

Alternatively, the MCT8316A GUI can be downloaded and installed offline using the download feature in the TI Cloud Gallery.



Figure 6-2. MCT8316A GUI Offline Installer

## 7 MSP430FR2355 Interface Firmware

The MSP430FR2355 on the MCT8316AEVM comes pre-programmed with the firmware necessary for communicating with the PC GUI and the MCT8316A. In order to reprogram or flash custom code on the MSP430FR2355, you will need an external MSP430 LaunchPad™ that includes the eZ-FET Debug Probe. In this example, we use the [MSP-EXP430FR2355 LaunchPad Development Kit](#) to provide the debug probe. Follow the steps below to download the code for the MCT8316AEVM to use with the GUI.

### 7.1 Downloading Code Composer Studio and Importing MSP430FR2355 Interface Firmware Code

1. Extract the “MCT8316AEVM\_MSP430FR2355\_Firmware\_GUI.zip” to a location on the computer.
2. Download the latest version of [Code Composer Studio](#). This will set up a ti folder in the directory C:\ti.
  - a. Accept all agreements, default install locations, and hit “Next” to proceed through menus.
  - b. In the “Select Components” window, ensure to check “MSP430 Low-Power MCUs” to install the required packages for the MSP430 LaunchPad Evaluation Kits.
3. After installing, run CCS and select a folder or the default to use as the Workspace to store any new projects. The location and naming convention can be changed based on the user’s preference. Click the OK button to accept.
4. In CCS, click on the Project tab and select “Import CCS Projects”. Click on Browse.
5. Select the “MCT8316AEVM\_MSP430FR2355\_Firmware\_GUI” folder installed from step 1.
6. Import the project “MCT8316AEVM\_MSP430FR2355\_Firmware\_GUI” into your workspace as shown in [Figure 7-1](#).

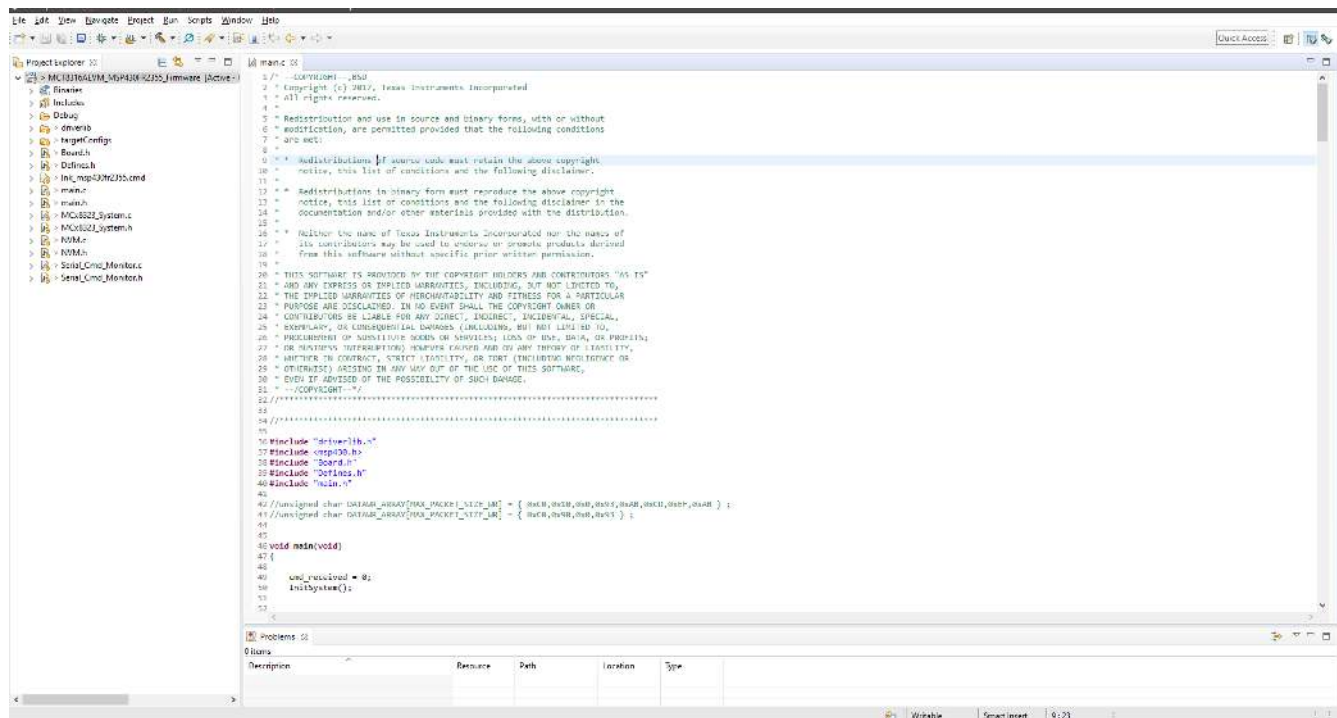

Figure 7-1. MSP430FR2355 Interface Firmware Code in Code Composer Studio

### 7.2 Using the eZ-FET to Program the MSP430FR2355

The eZ-FET Debug Probe on the MSP430FR2355 LaunchPad uses a SPI-by-Wire JTAG interface to program the MSP430FR2355 MCU on the MCT8316AEVM. Consult the [MSP430 LaunchPad Development Kits](#) for MSP430 LaunchPads that include an onboard eZ-FET Debug Probe.

1. Remove the GND, 3V3, SBWTDIO, and SBWTCK jumpers from the MSP430 LaunchPad.
2. Connect the top pins on the eZ-FET side of the LaunchPad of the GND, 3V3, SBWTDIO, and SBWTCK signals to their respective pins on J4 of the MCT8316AEVM as shown in [Table 7-1](#) and [Figure 7-2](#).



3. Connect a micro-USB cable to the MSP430 LaunchPad and the PC.
4. Click on the Build Project icon or “Ctrl” + B to ensure the project builds successfully. Accept any updates if needed from the Console.
5. Click on Debug Project to set up a debug session and press the Play button to run the code.
6. Stop the debug session, close Code Composer Studio, disconnect the SPI-by-Wire jumpers, and unplug the micro-USB cable from the MSP430 LaunchPad.

**Table 7-1. SPY-BI-Wire Connections Needed to Program MSP430FR2355**

MSP430 LaunchPad™ (eZ-FET Debug Probe Side) (J101)	MCT8316AEVM 4-pin SPI-by-Wire Header (J4)
GND	GND
3V3	3.3V
SBWTDIO	SBWTDIO
SBWTCK	SBWTCK

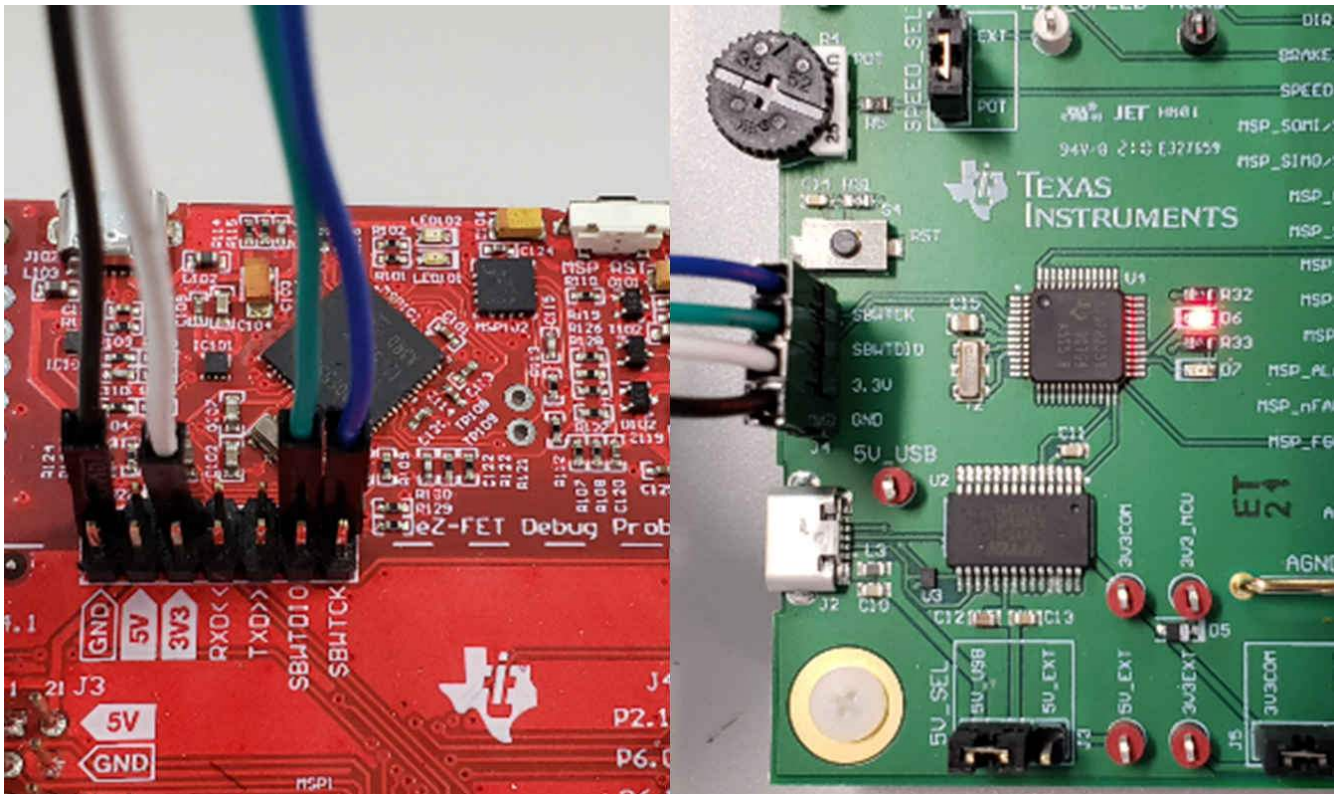

**Figure 7-2. MSP430 LaunchPad™ eZ-FET Probe Connected to MCT8316AEVM**

## 8 Schematics

### 8.1 Main Supply and Pi Filter

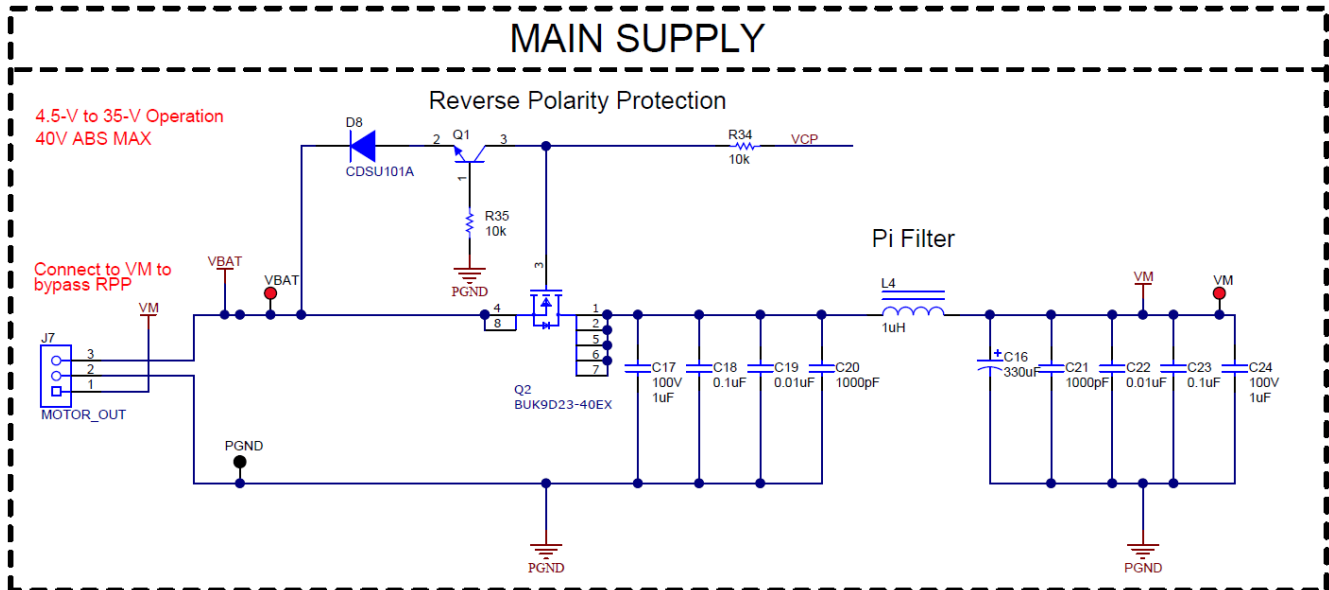

Figure 8-1. Main Supply and Pi Filter Schematic

### 8.2 Connectors and Interface

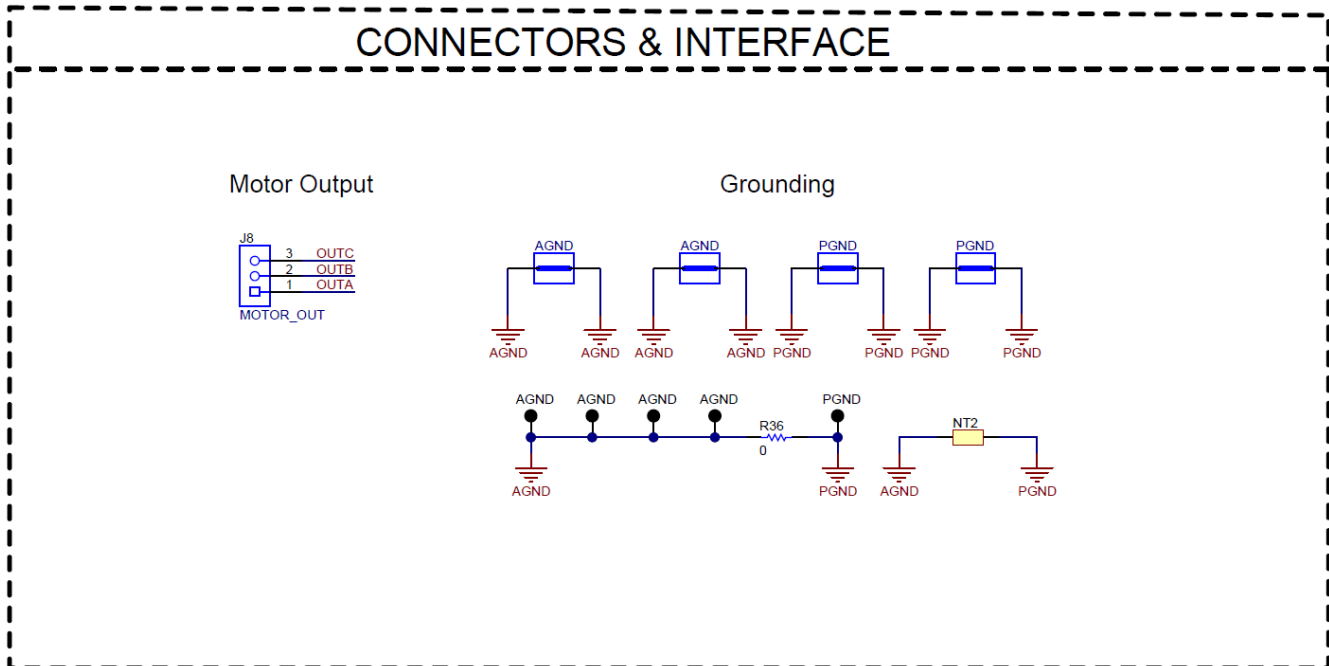

Figure 8-2. Connectors and Interface Schematic

### 8.3 USB to UART

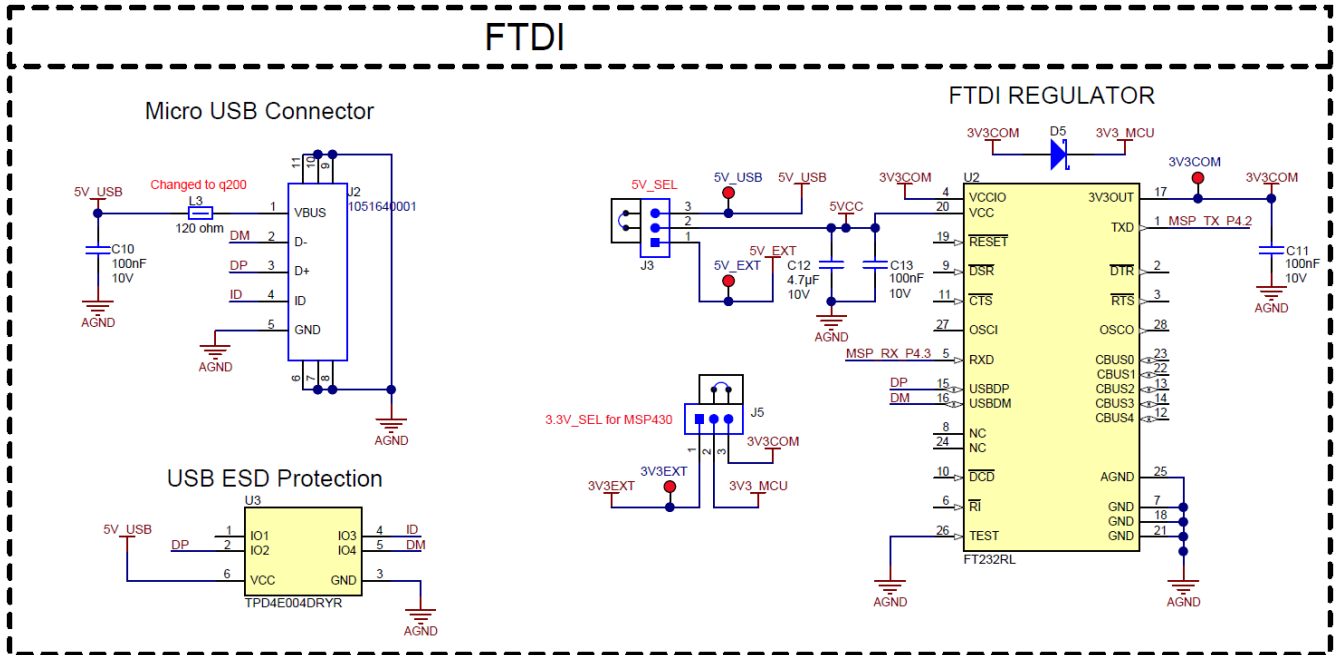

Figure 8-3. USB to UART Schematic

### 8.4 MCU Programming and Debug

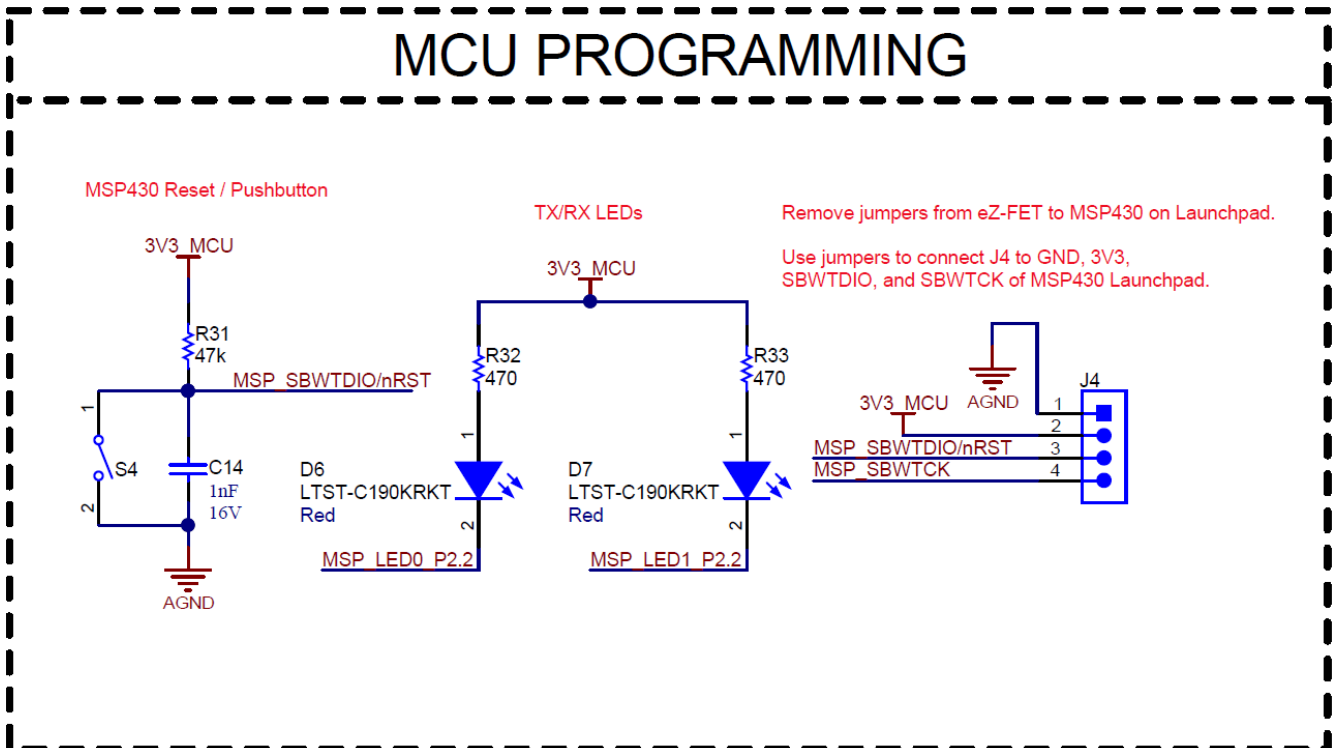

Figure 8-4. MCU Programming and Debug Schematic



### 8.5 MSP430FR2355 MCU

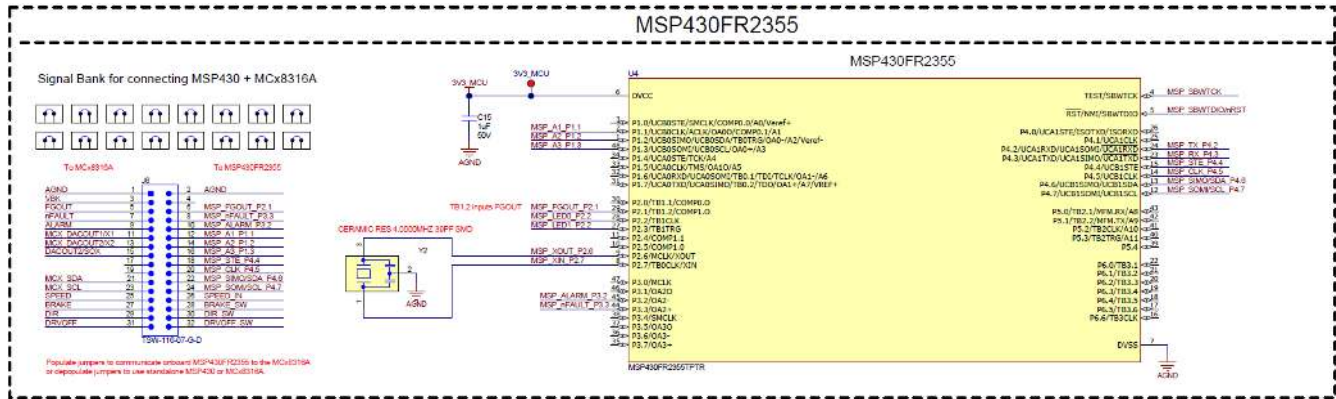

Figure 8-5. MSP430FR2355 MCU Schematic

### 8.6 MCT8316A 3-Phase Sensorless Trapezoidal Control Integrated Driver

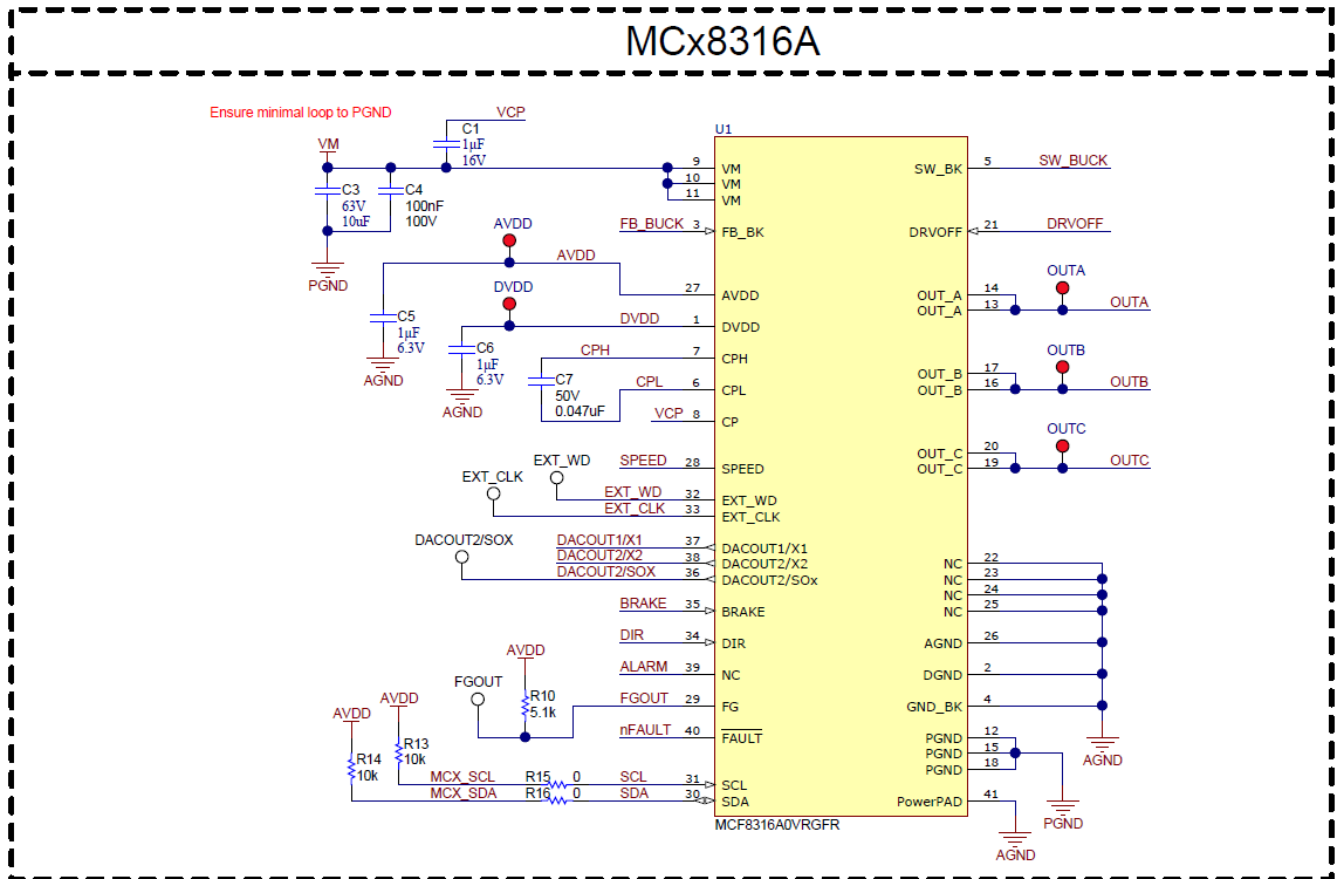

Figure 8-6. MCT8316A 3-Phase Sensorless Trapezoidal Control Integrated Driver Schematic

## 8.7 Buck Regulator

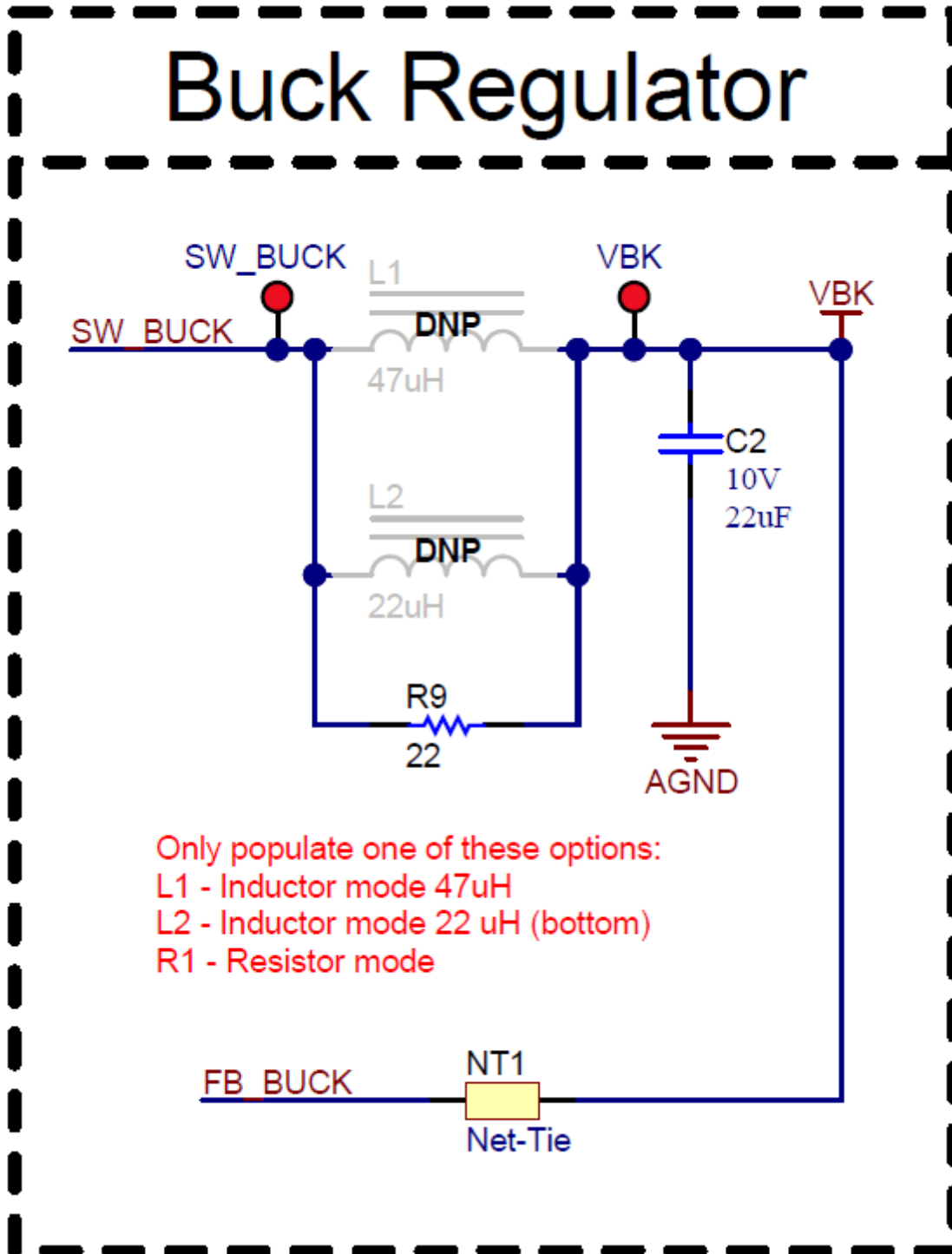

Figure 8-7. Buck Regulator Schematic

## 8.8 Status LEDs

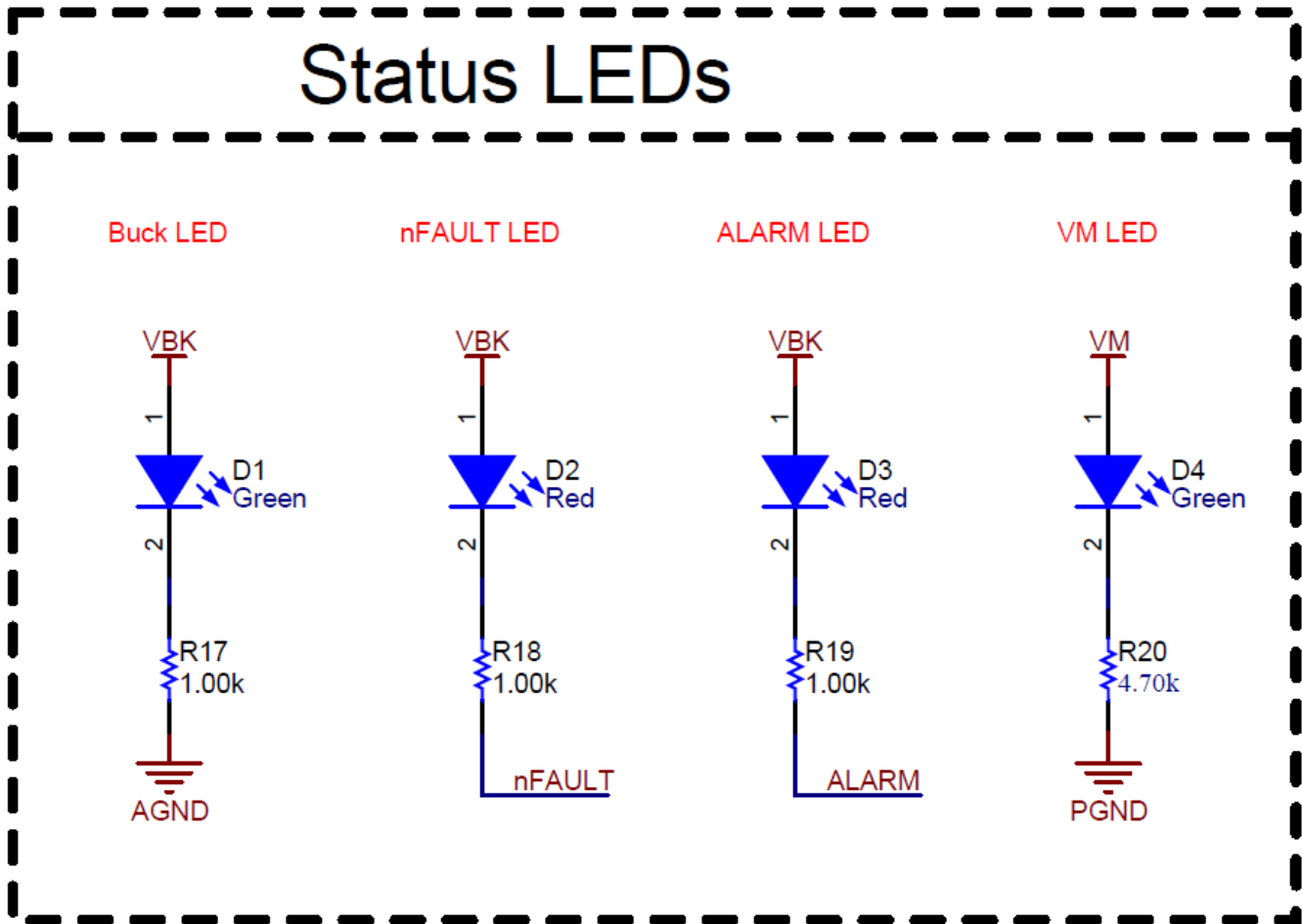

Figure 8-8. Status LEDs Schematic

## 8.9 Switches and Speed Input

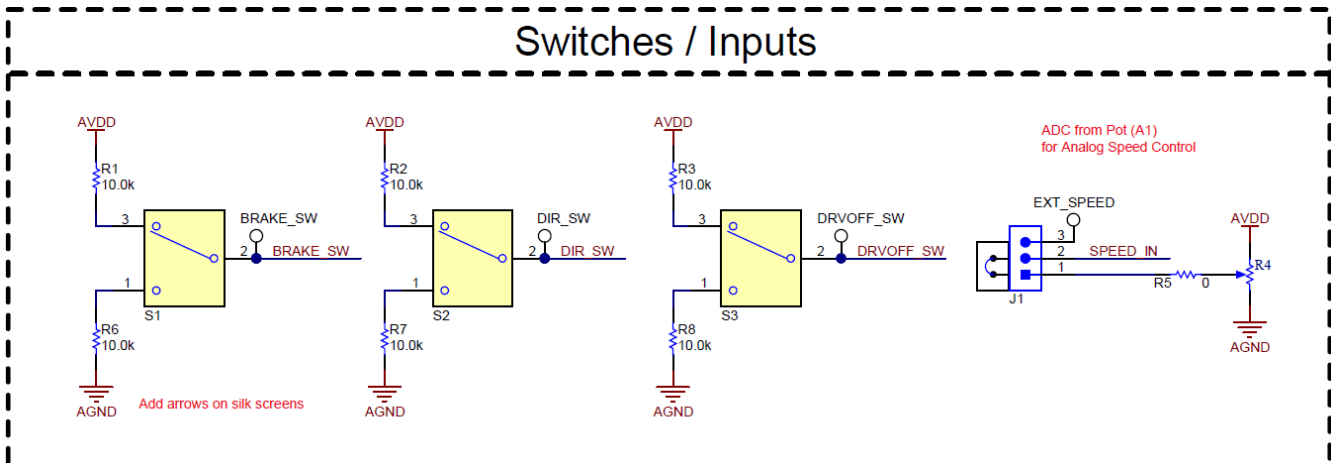

Figure 8-9. Switches and Speed Input Schematic

## 9 Revision History

NOTE: Page numbers for previous revisions may differ from page numbers in the current version.

DATE	REVISION	NOTES
	*	Initial Release



## IMPORTANT NOTICE AND DISCLAIMER

TI PROVIDES TECHNICAL AND RELIABILITY DATA (INCLUDING DATA SHEETS), DESIGN RESOURCES (INCLUDING REFERENCE DESIGNS), APPLICATION OR OTHER DESIGN ADVICE, WEB TOOLS, SAFETY INFORMATION, AND OTHER RESOURCES "AS IS" AND WITH ALL FAULTS, AND DISCLAIMS ALL WARRANTIES, EXPRESS AND IMPLIED, INCLUDING WITHOUT LIMITATION ANY IMPLIED WARRANTIES OF MERCHANTABILITY, FITNESS FOR A PARTICULAR PURPOSE OR NON-INFRINGEMENT OF THIRD PARTY INTELLECTUAL PROPERTY RIGHTS.

These resources are intended for skilled developers designing with TI products. You are solely responsible for (1) selecting the appropriate TI products for your application, (2) designing, validating and testing your application, and (3) ensuring your application meets applicable standards, and any other safety, security, regulatory or other requirements.

These resources are subject to change without notice. TI grants you permission to use these resources only for development of an application that uses the TI products described in the resource. Other reproduction and display of these resources is prohibited. No license is granted to any other TI intellectual property right or to any third party intellectual property right. TI disclaims responsibility for, and you will fully indemnify TI and its representatives against, any claims, damages, costs, losses, and liabilities arising out of your use of these resources.

TI's products are provided subject to [TI's Terms of Sale](#) or other applicable terms available either on [ti.com](http://ti.com) or provided in conjunction with such TI products. TI's provision of these resources does not expand or otherwise alter TI's applicable warranties or warranty disclaimers for TI products.

TI objects to and rejects any additional or different terms you may have proposed.

Mailing Address: Texas Instruments, Post Office Box 655303, Dallas, Texas 75265  
Copyright © 2022, Texas Instruments Incorporated