

**iPass  
Vertical zHD  
Press-In Tool**

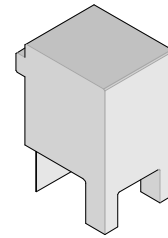

**Application Tooling  
Specification Sheet**



**Order No. 62203-0770**

**FEATURES**

- Lip provided for positive alignment to connector assembly
- Inserts connector to a PCB without damage to the board

**SCOPE**

Products: iPass zHD Vertical connector assembly. See Product List below for specific part numbers.

**Product List**

The following is a partial list of the product order numbers and their specifications this tool is designed to run. Updates to this list are available on [www.molex.com](http://www.molex.com).

Connector Series No.	Assembly Order No.		
170729	170729-0001	170729-0002	170729-0004

**Tool Setup**

Depending on the number of connectors to be installed and/or the press used, this tool can be used alone or with a group of press-in tools, mounted in a 62201-95XX rail (ordered separately). See Figure 1.

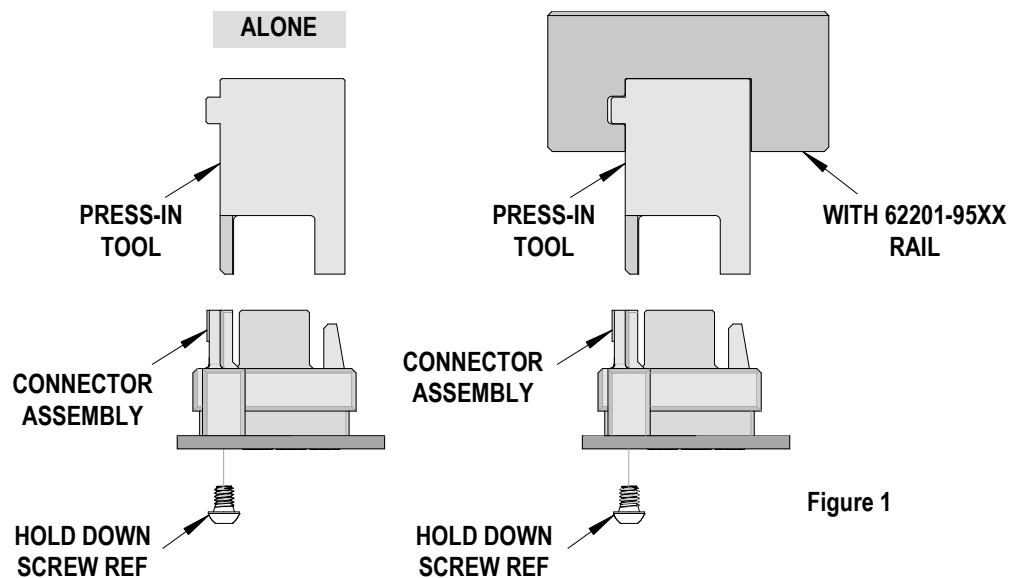

Figure 1

The 62201-95XX rail is available in a variety of lengths to accommodate multiple press-in tools.

Rail Part Number	Rail Overall Length
62201-9501	24mm (0.94 in)
62201-9502	72mm (2.83 in)
62201-9503	156mm (6.14 in)
62201-9504	216mm (8.50 in)
62201-9509	254mm (10.0 in)
62201-9511	305mm (12.0 in)

Reference: This Press-In Tool is 12.0mm (0.47 in.) long.

### Printed Circuit Board (PCB) Support

The zHD connector assembly requires significant force to press into the PCB. To prevent excessive PCB flexure and/or damage to the PCB, a support plate is strongly recommended directly beneath the connector hole pattern.

Due to the custom nature of every application, Molex does not offer any PCB support plate. The customer must furnish their own support plate.

When creating the PCB support plate, remember to allow clearance for the connector pins if they pass through the PCB thickness.

### Tool Operation

1. Carefully place the connector assembly on the PCB by hand.
2. Place the press-in-tool on top of the connector assembly with the legs of the tool over the connector assembly. See Figure 2.

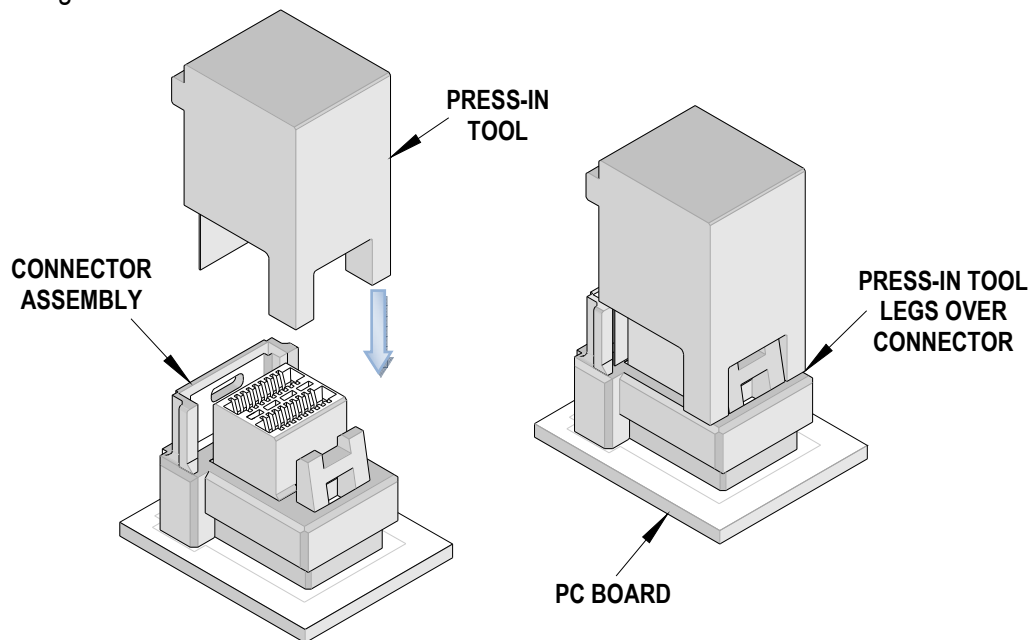
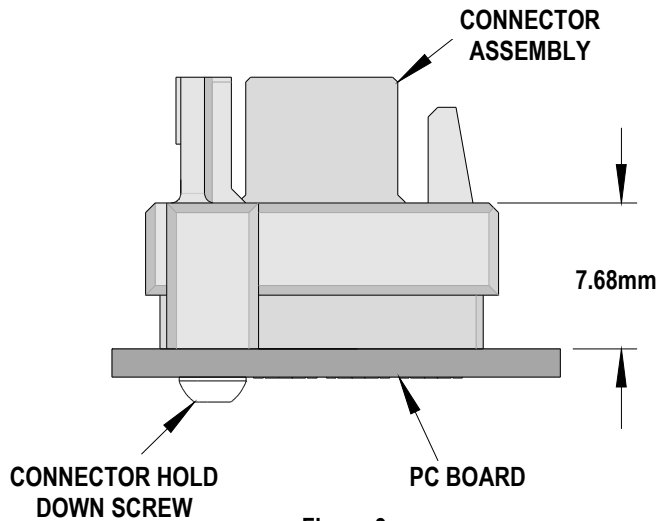

Figure 2

3. Place tool, connector, and PCB, in a press of suitable size and force, and seat the connector assembly as shown. The support plate (furnished by the customer) under the PCB must have clearance for the connector pins as they pass through the PCB.
4. Add the required number of hold down screws to secure the zHD assembly to the PCB. See module product sales drawing SD-170729-0001 for correct mounting screw length.



3. The connector assembly must be fully seated on the printed circuit board and not exceed the dimensions shown in figure 3.

**CAUTION:** To prevent injury, never operate any press without the guards in place. Refer to the press manufacturer's instruction manual.

**CAUTION:** Molex application tooling specifications are valid only when used with Molex connectors and tooling.

### Contact Information

For more information on Molex application tooling please contact Molex at 1-800-786-6539.

Visit our Web site at <http://www.molex.com>