

THIS DRAWING IS UNPUBLISHED. RELEASED FOR PUBLICATION  
 © COPYRIGHT BY TYCO ELECTRONICS CORPORATION. ALL RIGHTS RESERVED.

LOC	DIST	REVISIONS			
P	LTR	DESCRIPTION	DATE	DWN	APVD
GP	00	A	REVISED PER ECO-06-025935	12/FEB/07	ZMR WLM

1. ALL DIMENSIONS SHOWN ARE FOR REFERENCE ONLY UNLESS OTHERWISE SPECIFIED.
2. BRIGHT ZINC PLATE WITH CLEAR HEXAVALENT CHROMATE COATING.
3. BRIGHT ZINC PLATE WITH CLEAR TRIVALENT CHROMATE COATING.

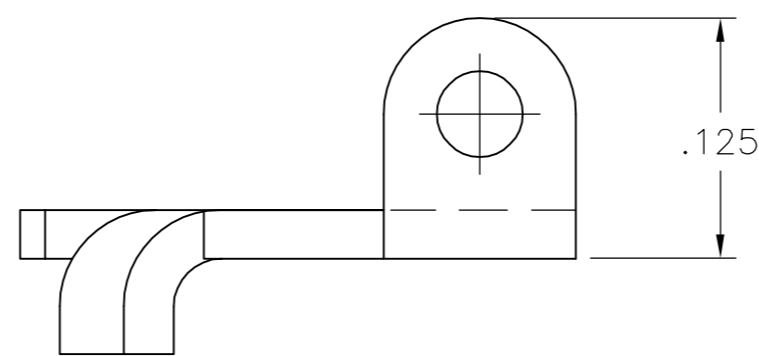
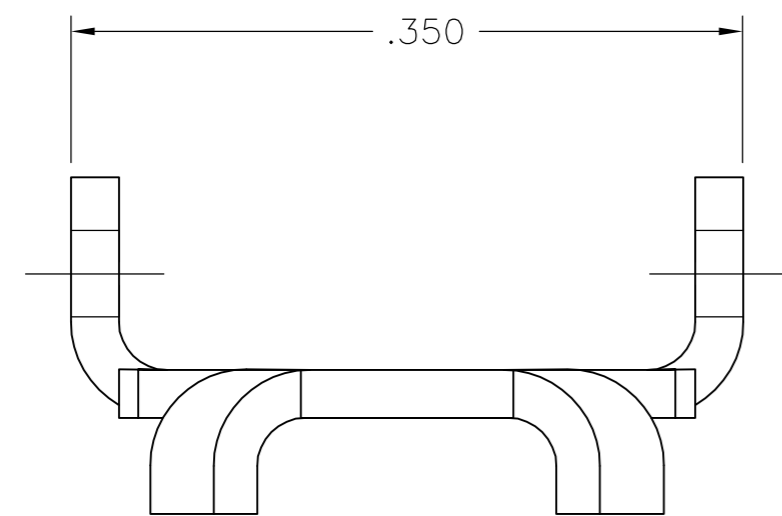
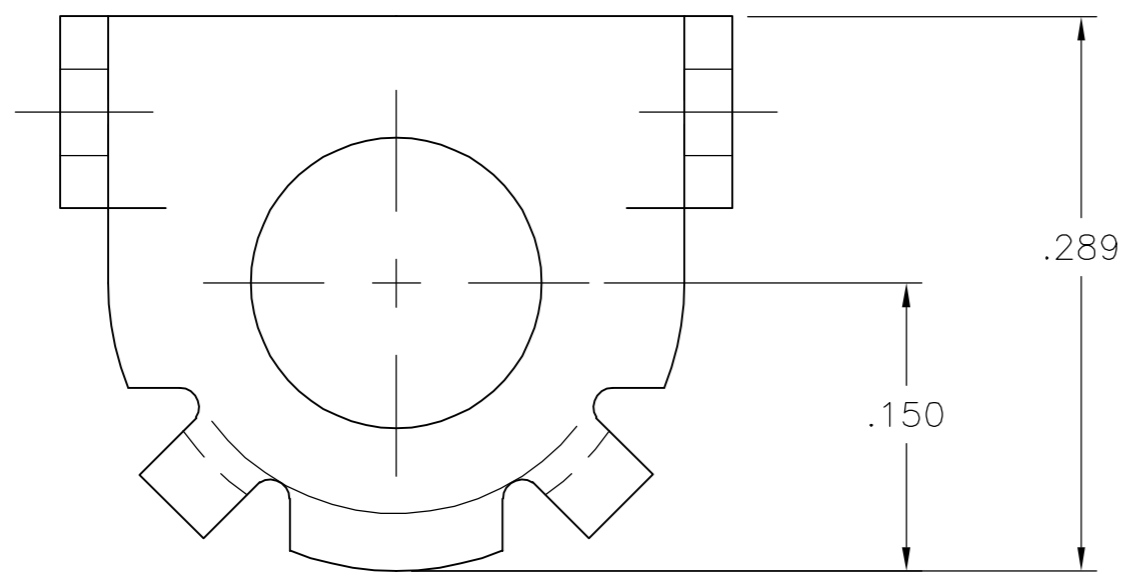

	3	552101-3
OBSOLETE	2	552101-1
	FINISH	PART NUMBER

THIS DRAWING IS A CONTROLLED DOCUMENT.		DWN	16JAN06	Tyco Electronics Corporation	
		B. MCMASTER		Harrisburg, PA 17105-3608	
DIMENSIONS: INCHES		CHK	16JAN06	NAME	
		W. MILLHIMES		MOUNTING BRACKER, BAIL	
TOLERANCES UNLESS OTHERWISE SPECIFIED:		APVD	16JAN06	SIZE	CAGE CODE
0 PLC ± -		W. MILLHIMES		A2	00779
1 PLC ± -		PRODUCT SPEC		DRAWING NO	RESTRICTED TO
2 PLC ± -		APPLICATION SPEC		C=552101	-
3 PLC ± -				SCALE	SHEET
4 PLC ± -				10:1	1 of 1
ANGLES ± -		WEIGHT	-	REV	A
FINISH		CUSTOMER DRAWING			
2 3					