



STEVAL-ISA043V2

1.5 A /1.2 V high-frequency synchronous buck converter demonstration board based on the ST1S06

Data brief

Features

- Adjustable current-mode pulse width modulation (PWM) synchronous, step-down DC-DC converter with inhibit function
- Input voltage, V_{in} : 2.5 V to 5.5 V
- Output voltage, V_{out} : 3.3 V
- Output current, I_{out} : 1.5 A
- Switching frequency: 1.5 MHz
- RoHS compliant

Description

This demonstration board, based on the ST1S06, is an adjustable current-mode PWM synchronous, step-down DC-DC converter with inhibit function. It is optimized for powering all low-voltage applications and, more generally, to replace the high-current linear solution when the power dissipation may cause overheating of the application environment.

It provides up to 1.5 A over an input voltage range of 2.5 V to 5.5 V.

A high switching frequency (1.5 MHz) enables the use of tiny surface-mounted components (SMD). In addition to the resistor divider used to set the output voltage value, only an inductor and two capacitors are required.

Moreover, low output ripple is guaranteed by the current-mode PWM topology and by the use of low series resistance (ESR) SMD ceramic capacitors.

The device is thermal protected and current limited to prevent damage due to accidental short circuits.

It is a complete 1.5 A switching regulator with its internal compensation eliminating the need for additional components.

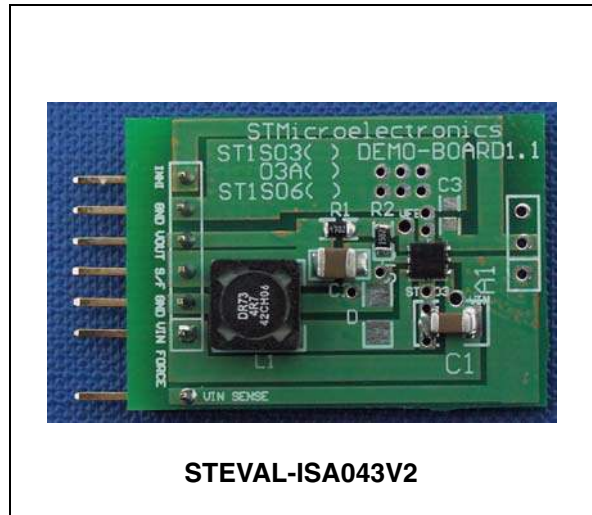

STEVAL-ISA043V2

The constant-frequency, current-mode, PWM architecture and stable operation with ceramic capacitors results in a low, predictable output ripple. To clamp the error amplifier reference voltage, this device includes a soft-start control block generating a voltage ramp.

The ST1S06 is available in a 6L-DFN 3x3 package.

1 Circuit schematic

Figure 1. Circuit schematic

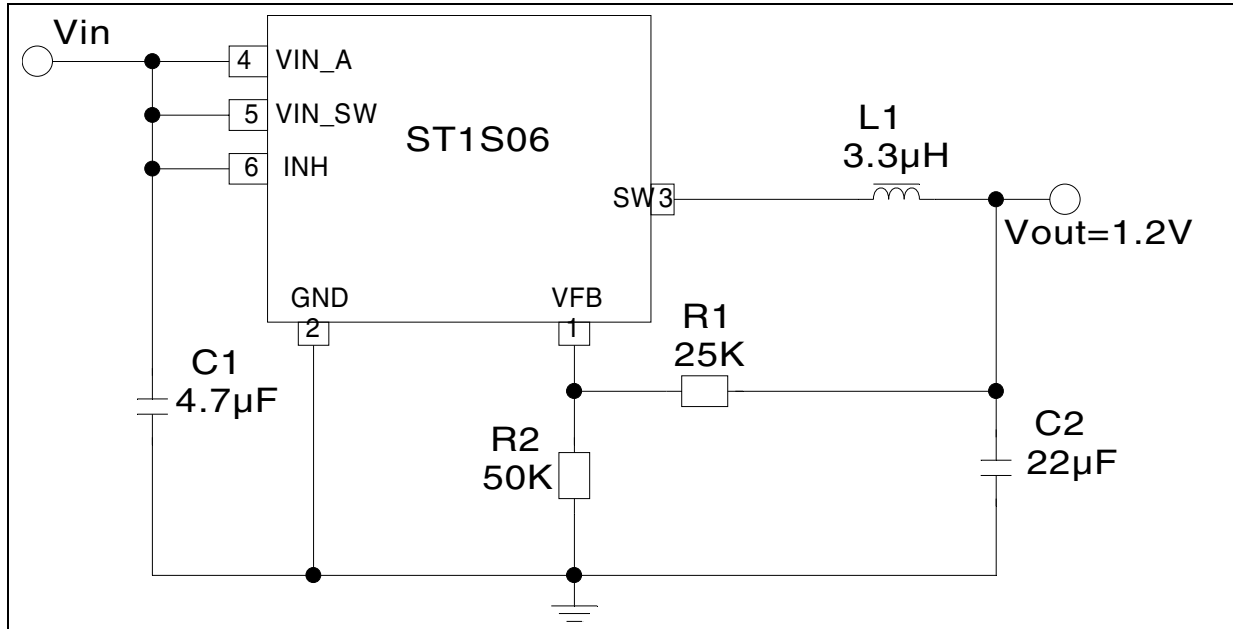

2 Revision history

Table 1. Document revision history

Date	Revision	Changes
10-Nov-2010	1	Initial release.

Please Read Carefully:

Information in this document is provided solely in connection with ST products. STMicroelectronics NV and its subsidiaries ("ST") reserve the right to make changes, corrections, modifications or improvements, to this document, and the products and services described herein at any time, without notice.

All ST products are sold pursuant to ST's terms and conditions of sale.

Purchasers are solely responsible for the choice, selection and use of the ST products and services described herein, and ST assumes no liability whatsoever relating to the choice, selection or use of the ST products and services described herein.

No license, express or implied, by estoppel or otherwise, to any intellectual property rights is granted under this document. If any part of this document refers to any third party products or services it shall not be deemed a license grant by ST for the use of such third party products or services, or any intellectual property contained therein or considered as a warranty covering the use in any manner whatsoever of such third party products or services or any intellectual property contained therein.

UNLESS OTHERWISE SET FORTH IN ST'S TERMS AND CONDITIONS OF SALE ST DISCLAIMS ANY EXPRESS OR IMPLIED WARRANTY WITH RESPECT TO THE USE AND/OR SALE OF ST PRODUCTS INCLUDING WITHOUT LIMITATION IMPLIED WARRANTIES OF MERCHANTABILITY, FITNESS FOR A PARTICULAR PURPOSE (AND THEIR EQUIVALENTS UNDER THE LAWS OF ANY JURISDICTION), OR INFRINGEMENT OF ANY PATENT, COPYRIGHT OR OTHER INTELLECTUAL PROPERTY RIGHT.

UNLESS EXPRESSLY APPROVED IN WRITING BY AN AUTHORIZED ST REPRESENTATIVE, ST PRODUCTS ARE NOT RECOMMENDED, AUTHORIZED OR WARRANTED FOR USE IN MILITARY, AIR CRAFT, SPACE, LIFE SAVING, OR LIFE SUSTAINING APPLICATIONS, NOR IN PRODUCTS OR SYSTEMS WHERE FAILURE OR MALFUNCTION MAY RESULT IN PERSONAL INJURY, DEATH, OR SEVERE PROPERTY OR ENVIRONMENTAL DAMAGE. ST PRODUCTS WHICH ARE NOT SPECIFIED AS "AUTOMOTIVE GRADE" MAY ONLY BE USED IN AUTOMOTIVE APPLICATIONS AT USER'S OWN RISK.

Resale of ST products with provisions different from the statements and/or technical features set forth in this document shall immediately void any warranty granted by ST for the ST product or service described herein and shall not create or extend in any manner whatsoever, any liability of ST.

ST and the ST logo are trademarks or registered trademarks of ST in various countries.

Information in this document supersedes and replaces all information previously supplied.

The ST logo is a registered trademark of STMicroelectronics. All other names are the property of their respective owners.

© 2010 STMicroelectronics - All rights reserved

STMicroelectronics group of companies

Australia - Belgium - Brazil - Canada - China - Czech Republic - Finland - France - Germany - Hong Kong - India - Israel - Italy - Japan - Malaysia - Malta - Morocco - Philippines - Singapore - Spain - Sweden - Switzerland - United Kingdom - United States of America

www.st.com