

PART NUMBER	REVISION	DESCRIPTION	FEED TYPE
2151870-2	B	FINE CRIMP HEIGHT ADJUST	PNEUMATIC
7-2151870-2	B	PNEUMATIC AND CRIMP TOOLING KIT	PNEUMATIC
7-2151870-7	A	CRIMP TOOLING KIT	-

ATLANTIC VERSION TERMINATOR INTERFACE ADAPTER

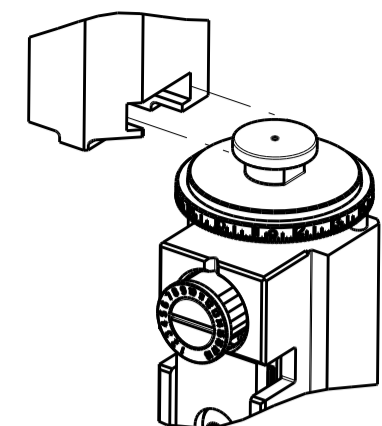

APPLICATOR DATA		
CRIMP	SIZE	TYPE
WIRE	3.50 mm [.138]	F
INSUL	4.19 mm [.165]	F

APPLICATOR INSTRUCTIONS 408-35042

TERMINAL DATA: MTA TERMINAL		MTA CRIMP SPECIFICATION	
TERMINAL NAME: TERMINAL POWER F800			
WIRE STRIP LENGTH	INSULATION DIAMETER RANGE		
5.40-5.77 mm [.213-.227 IN]	∅ 3.94mm MAX [.155 IN MAX]		
TERMINAL APPLICATION SPECIFICATION	BO-018.004A Rev 10		
TERMINALS APPLIED			
TE TERMINAL	MTA TERMINAL	TE TERMINAL	MTA TERMINAL
2113317-1	1707650		

WIRE SIZE	CRIMP HEIGHT mm [INCH]	CRIMP HEIGHT REFERENCE SETTING
2.50mm ²	2.00 +/- 0.05 [.079 +/- .002]	7.6
1.50mm ²	1.90 +/- 0.05 [.075 +/- .002]	8.5

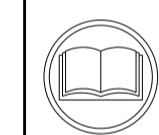

- RECOMMENDED SPARE PARTS
- REFER TO SUPPLIED INSTRUCTION SHEET FOR CLEANING, LUBRICATION AND STORAGE OF APPLICATOR.
- APPLY PART NUMBER 2-23419-6 LOCTITE TO THREADS OF ITEM 242.
- CRIMP HEIGHT REFERENCE SETTING WAS THE SETTING USED WHEN THE APPLICATOR WAS QUALIFIED AT THE FACTORY. ADJUSTMENT MAY BE NECESSARY WHEN RUNNING APPLICATOR IN THE FIELD.
- TERMINAL PITCH NOT COMPATIBLE WITH MECHANICAL FEED.

6. UNLESS SPECIFIED OTHERWISE TORQUE VALUES SHALL BE USED PER DOCUMENT, 101-35000.

***WARNING**
ON INSTALLATION, SET WIRE DISC TO CRIMP HEIGHT REFERENCE SETTING FOR LARGEST WIRE SIZE. CRIMP HEIGHT REFERENCE SETTINGS GREATER THAN THE VALUE SHOWN MAY CAUSE DAMAGE TO THE CRIMP TOOLING, REFER TO THE INSTRUCTION SHEET FOR PROPER SETUP AND ADJUSTMENTS.

LOC	DIST	REVISIONS			
A	66	REV	DATE	BY	APP'D
		A	RELEASED	08MAR2013	LG TE
		B	ECR-20-002406	19FEB2020	FZ TE

-	2	2	2168083-1	SCR, SKT HD CAP, RoHS, M3 X 8.0	269
-	1	1	1633782-6	FENCE	267
-	1	1	1803078-1	SPACER, PRECISION	259
-	1	1	2119641-1	FEED CAM, AIR FEED	248
-	1	1	2119082-6	CAM, SNAIL, INSULATION ADJUSTMENT	244
-	1	1	2079764-1	WASHER, WAVE SPRING, CREST-TO-CREST	243
-	1	1	2119083-1	RETAINER, INSULATION DIAL	242
-	1	1	7-18023-7	SCR, SKT HD CAP M3 X 4.0	241
-	1	1	2844940-2	AIR FEED MODULE	238
-	REF	REF	994970-2	COUNTER, MAGNETIC	164
-	1	1	2844908-1	SCREW, LOCKING	99
-	1	1	2844907-1	POST, LOCKING	98
-	1	1	1-690438-0	FRONT STRIP GUIDE	96
-	2	2	2168083-1	SCR, SKT HD CAP, RoHS, M3 X 8.0	95
-	1	1	318563-1	GUARD, FRONT CHIP	89
-	1	1	1-455888-6	SPACER, CRIMPER	82
-	2	2	2079383-4	SCR, BHSC, RoHS (M4 X 8)	79
-	1	1	1803096-1	EXTENSION PLATE	78
-	1	1	1803607-3	DOCUMENTATION PACKAGE	71
-	1	1	2119740-1	TAG, IDENTIFICATION	67
-	2	2	2168078-1	SCREW, DRIVE, RH, RoHS, 2 x .188	66
-	2	2	2-18032-5	SCR, SET, FLT PNT, M5 X 20.0	61
-	1	1	2168083-2	SCR, SKT HD CAP, RoHS, M4 X 8.0	60
-	1	1	5-18022-5	SCR, HEX HD CAP, M4 X 6.0	59
-	1	1	1338683-8	FEED PAWL	56
-	4	4	2168083-3	SCR, SKT HD CAP, RoHS, M4 X 12.0	54
-	1	1	2168083-9	SCR, SKT HD CAP, RoHS, M4 X 20	53
-	1	1	2-2168083-6	SCR, SKT HD CAP, RoHS, M4 X 18	53
-	1	1	1803382-2	HOLD DOWN, SPRING LOADED	50
-	1	1	18023-9	SCR, SKT HD CAP M4 X 6.0	49
-	1	1	1803583-9	APPLICATOR BASIC ASSEMBLY, SF	46
-	1	1	1803515-2	RAM ASSEMBLY, SF ATLANTIC	44
-	1	1	1803602-2	SCR, BHSC, RoHS (M8 X 40)	41
-	1	1	2-1752356-0	SUPPORT, TERMINAL	34
-	2	2	2079383-5	SCR, BHSC, RoHS (M4 X 20)	33
-	2	2	2-2844962-0	SPACER, CYLINDRICAL, STRIP GUIDE	30
-	1	1	2844992-3	ASSEMBLY, STRIP GUIDE	29
-	1	1	1-455888-0	SPACER, CRIMPER	28
-	2	2	22283-1	SPRING, COMPRESSION	27
-	1	1	356835-1	LEVER, DRAG RELEASE	26
-	1	1	240792-1	DRAG, TERMINAL	25
-	1	1	1320928-4	STRIP GUIDE	24
-	1	1	980371-4	SCR, SKT HD SHLDR 5.0 DIA X 6.0	23
-	1	1	2168083-2	SCR, SKT HD CAP, RoHS, M4 X 8.0	21
-	1	1	1-18028-2	WASHER, FLAT, REG M4	20
-	1	1	2119533-1	STRIPPER, SIDE FEED	19
-	1	1	2119806-1	INSERT, SHEAR	13
-	1	1	3-22280-3	SPRING, COMPRESSION	12
-	1	1	1-356885-4	STOP, SHEAR	11
-	1	1	2119805-1	SHEAR HOLDER, FRONT	10
-	1	1	318707-1	FLOATING SHEAR, FRONT	9
-	1	2	1-3-1633927-6	ANVIL, COMBINATION	8
-	1	1	1-240641-5	SPACER	7
-	-	-	-	-	6
-	1	1	2119757-8	DEPRESSOR, SHEAR	5
-	1	1	1-238011-4	BLOCK, CRIMPER SPACER	4
-	1	2	1-1803017-3	CRIMPER, INSULATION F	3
-	1	1	1-455888-0	SPACER, CRIMPER	2
-	1	2	1-7-1633609-1	CRIMPER, WIRE	1

DIMENSIONS:		TOLERANCES UNLESS OTHERWISE SPECIFIED:		MATERIAL:		FINISH:		WEIGHT:		SCALE:	
mm	0 PLC ±	1 PLC ±	2 PLC ±	3 PLC ±	4 PLC ±	ANGLES					

ATLANTIC VERSION
Shown on sheets 1 of 4 & 2 of 4
(Pacific version shown on sheets 3 of 4 & 4 of 4)

LOC	DIST	REVISIONS					
A	66	P	LTN	DESCRIPTION	DATE	DWN	APVD
		-		SEE SHEET 1		-	-

FEED TYPE

PNEUMATIC

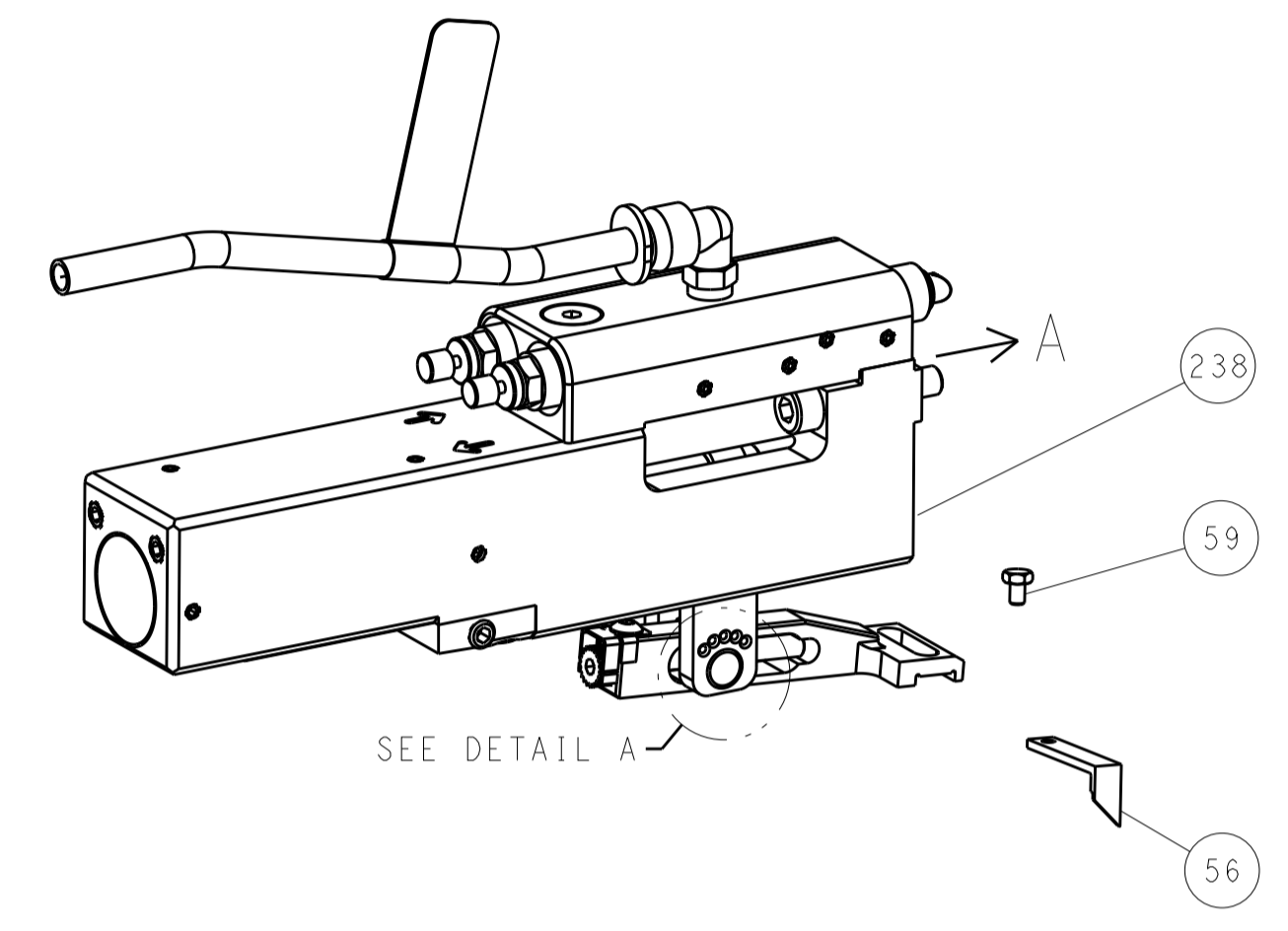

FEED SPRING SETTING POSITION (SHOWN FROM REAR SIDE)

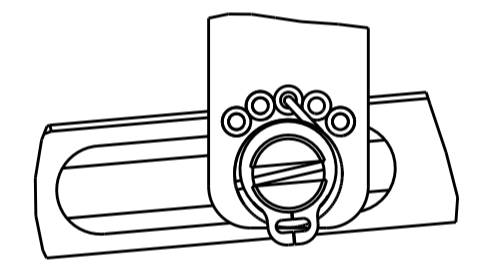

DETAIL A

CAM POSITION

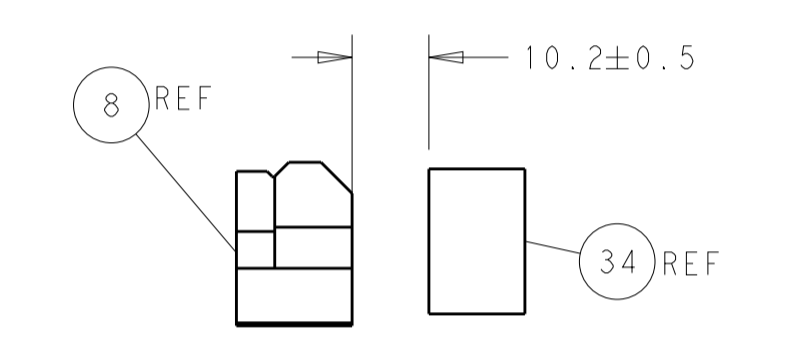
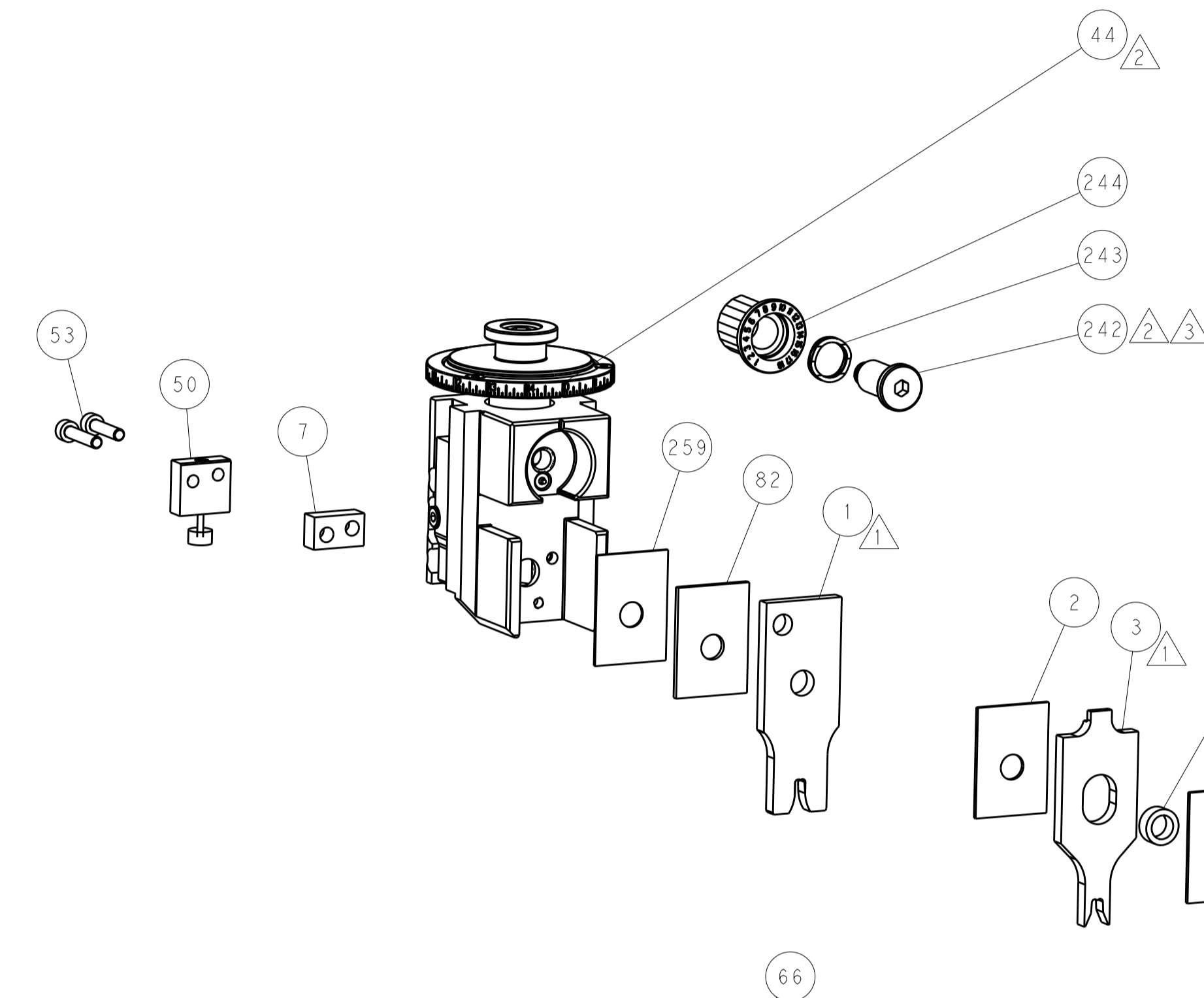
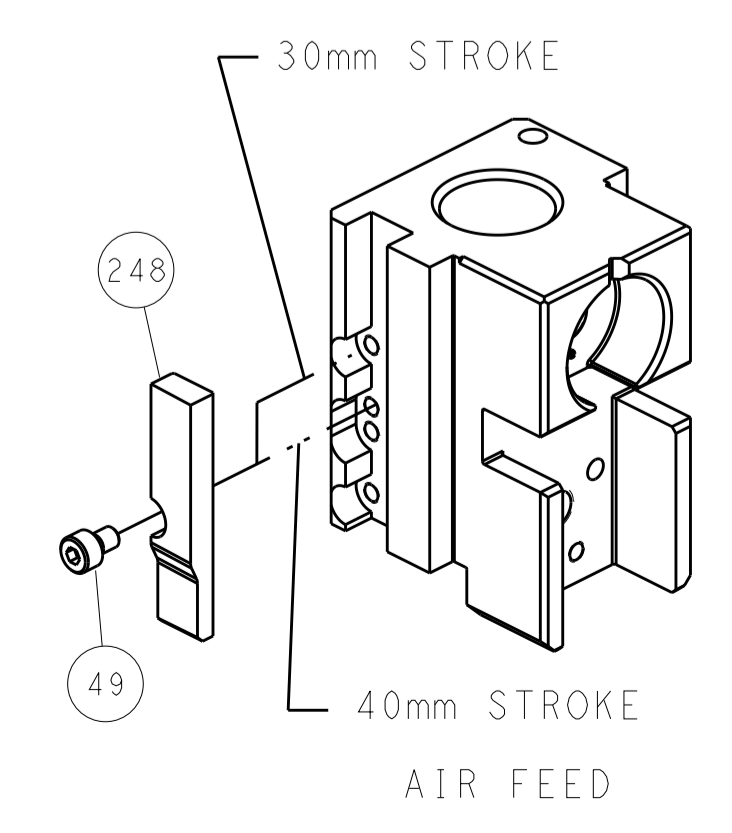

TERMINAL SUPPORT LOCATION

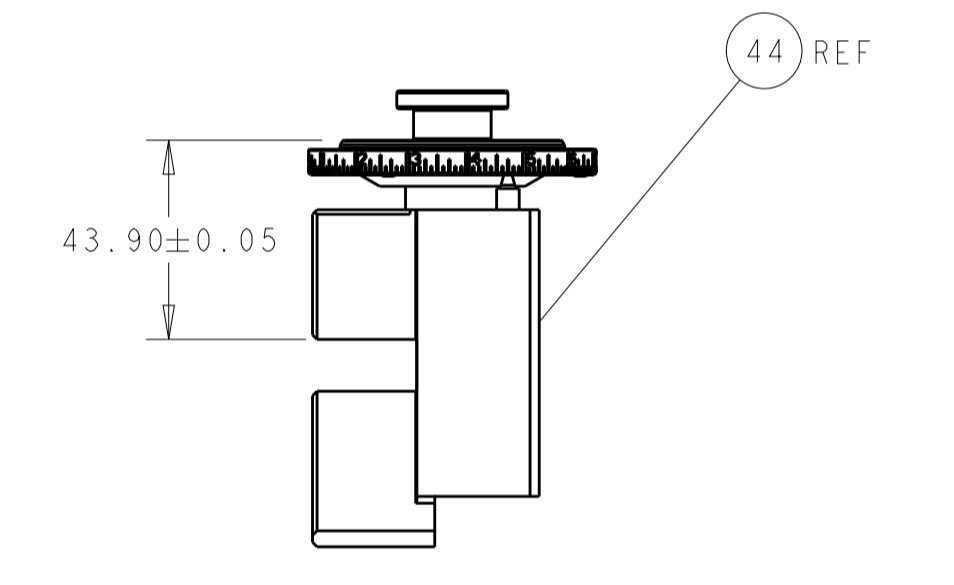

RAM SET-UP

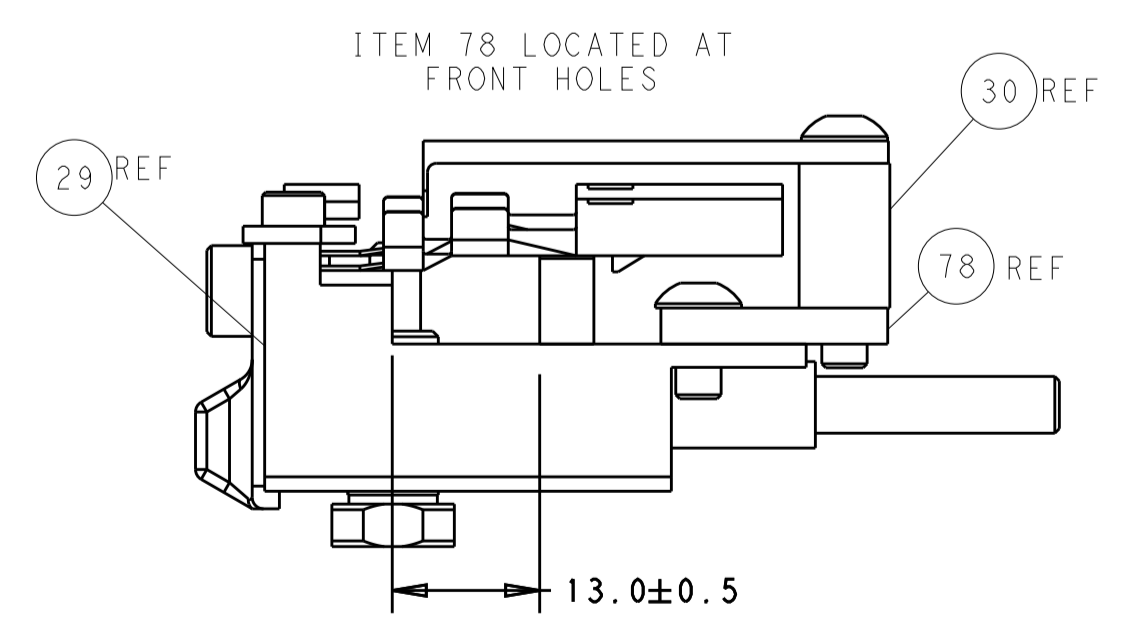

FEED TRACK POSITION GUIDE BY INSULATION BARREL

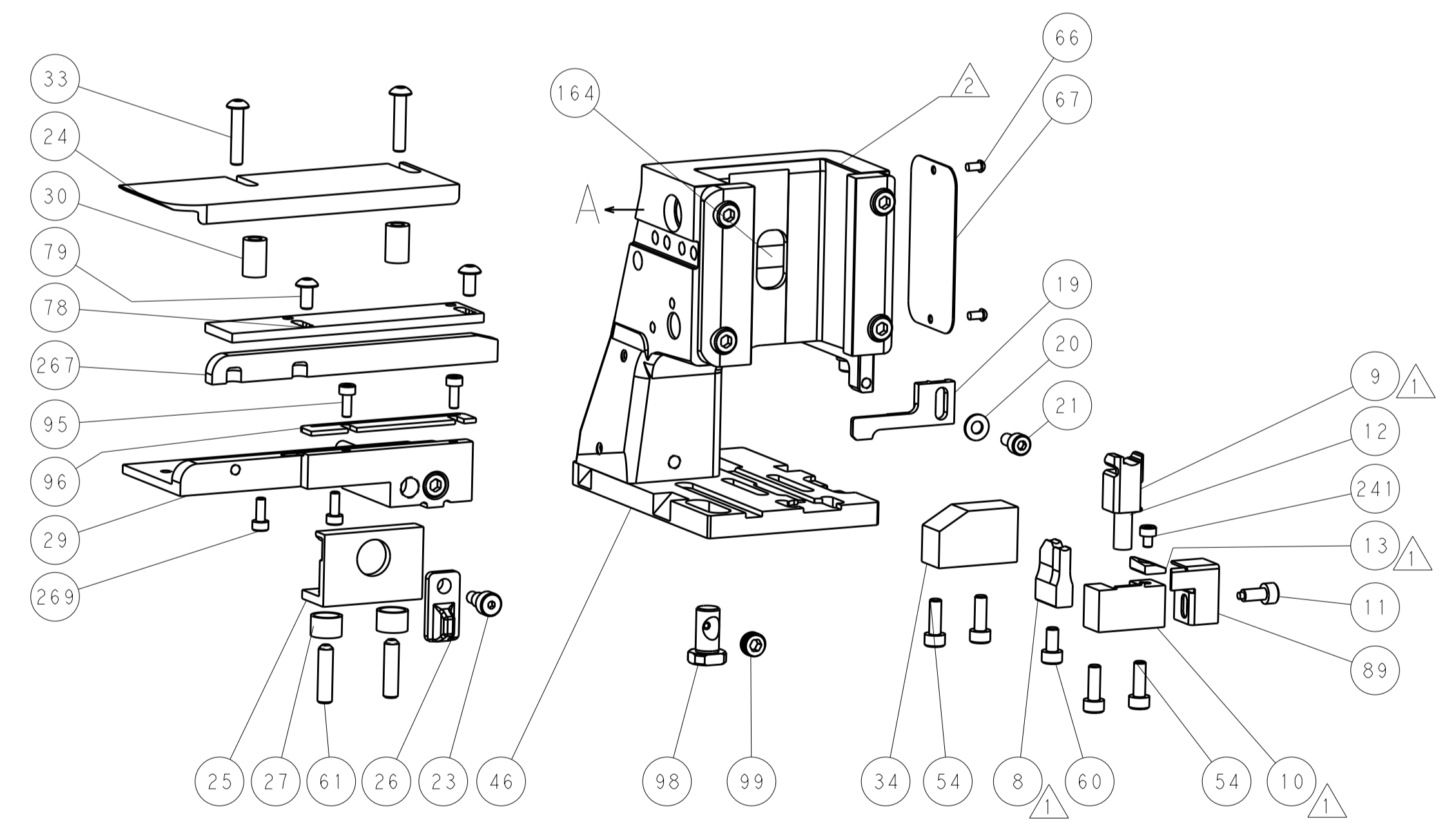

ATLANTIC VERSION
 Shown on sheets 1 of 4 & 2 of 4
 (Pacific version shown on sheets 3 of 4 & 4 of 4)

<small>THE INFORMATION CONTAINED HEREIN IS UNCLASSIFIED EXCEPT WHERE SHOWN OTHERWISE. IT IS SUBJECT TO CHANGE WITHOUT NOTICE AND WITHOUT OBLIGATION. SHOULD BE CONTACTED FOR THE LATEST REVISION.</small>		DWN: L.GROSS 07FEB2013 CHK: T.ELBIN 07FEB2013 APVD: M.CLEFFORD 07FEB2013	TE Connectivity Harrisburg, PA 17105-3608
DIMENSIONS: mm TOLERANCES UNLESS OTHERWISE SPECIFIED: 0 PLC ± 1 PLC ± 2 PLC ± 3 PLC ± 4 PLC ± ANGLES ±		NAME: Ocean Side Feed Applicator PRODUCT SPEC: APPLICATION SPEC: SIZE: A1 CAGE CODE: 00779 DRAWING NO: 2151870	RESTRICTED TO:
MATERIAL: FINISH:		WEIGHT: Customer Accessible Production Drawing SCALE: 1:2 SHEET: 2 OF 4 REV: B	

PART NUMBER	REVISION	DESCRIPTION	FEED TYPE
2-2151870-2	B	FINE CRIMP HEIGHT ADJUST	PNEUMATIC
7-2151870-7	A	CRIMP TOOLING KIT	-

PACIFIC VERSION TERMINATOR
 INTERFACE ADAPTER

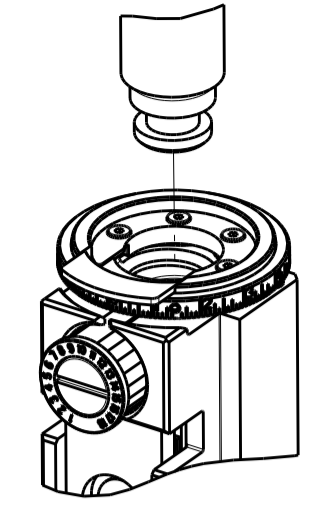

APPLICATOR DATA		
CRIMP	SIZE	TYPE
WIRE	3.50 mm [1.38]	F
INSUL	4.19 mm [1.65]	F
APPLICATOR INSTRUCTIONS 408-35042		

TERMINAL DATA: MTA TERMINAL		MTA CRIMP SPECIFICATION	
TERMINAL NAME: TERMINAL POWER F800			
WIRE STRIP LENGTH		INSULATION DIAMETER RANGE	
5.40-5.77 mm [1.213-.227 IN]		3.94mm MAX [1.155 IN MAX]	
TERMINAL APPLICATION SPECIFICATION	B0-018.004A Rev 10		
TERMINALS APPLIED Δ			
TE TERMINAL	MTA TERMINAL	TE TERMINAL	MTA TERMINAL
2113317-1	1707650		

WIRE SIZE	CRIMP HEIGHT mm [INCH]	CRIMP HEIGHT REFERENCE SETTING
2.50mm2	2.00 +/- 0.05 [1.079 +/- .002]	7.6
1.50mm2	1.90 +/- 0.05 [1.075 +/- .002]	8.5



- Δ RECOMMENDED SPARE PARTS
- Δ REFER TO SUPPLIED INSTRUCTION SHEET FOR CLEANING, LUBRICATION AND STORAGE OF APPLICATOR.
- Δ APPLY PART NUMBER 2-23419-6 LOCTITE TO THREADS OF ITEM 242.
- Δ CRIMP HEIGHT REFERENCE SETTING WAS THE SETTING USED WHEN THE APPLICATOR WAS QUALIFIED AT THE FACTORY. ADJUSTMENT MAY BE NECESSARY WHEN RUNNING APPLICATOR IN THE FIELD.
- Δ TERMINAL PITCH NOT COMPATIBLE WITH MECHANICAL FEED.

6. UNLESS SPECIFIED OTHERWISE TORQUE VALUES SHALL BE USED PER DOCUMENT, 101-35000.

***WARNING**
 ON INSTALLATION, SET WIRE DISC TO CRIMP HEIGHT REFERENCE SETTING FOR LARGEST WIRE SIZE. CRIMP HEIGHT REFERENCE SETTINGS GREATER THAN THE VALUE SHOWN MAY CAUSE DAMAGE TO THE CRIMP TOOLING, REFER TO THE INSTRUCTION SHEET FOR PROPER SETUP AND ADJUSTMENTS.

PACIFIC VERSION
 Shown on sheets 3 of 4 & 4 of 4
 (Atlantic version shown on sheets 1 of 4 & 2 of 4)

LOC	DIST	REVISIONS					
A	66	P	LTN	DESCRIPTION	DATE	OWN	APVD
		-		SEE SHEET 1			

-	2	2168083-1	SCR, SKT HD CAP, RoHS, M3 X 8.0	269	
-	1	1633782-6	FENCE	267	
-	1	1803078-1	SPACER, PRECISION	259	
-	1	2119082-6	CAM, SNAIL, INSULATION ADJUSTMENT	244	
-	1	2079764-1	WASHER, WAVE SPRING, CREST-TO-CREST	243	
-	1	2119083-1	RETAINER, INSULATION DIAL	242	
-	1	7-18023-7	SCR, SKT HD CAP M3 X 4.0	241	
-	1	2844940-2	AIR FEED MODULE	238	
-	REF	994970-2	COUNTER, MAGNETIC	164	
-	1	2119641-2	FEED CAM, AIR FEED	151	
-	1	2168083-8	SCR, SKT HD CAP, RoHS, M4 X 16	144	
-	4	2168083-9	SCR, SKT HD CAP, RoHS, M4 X 20	143	
-	-	2119653-2	FEED CAM, POST FEED	142	
-	1	1-1803583-0	APPLICATOR BASIC ASSEMBLY, SF	141	
-	1	1803516-2	RAM ASSEMBLY, SF PACIFIC	140	
-	1	2844908-1	SCREW, LOCKING	99	
-	1	2844907-1	POST, LOCKING	98	
-	1	1-690438-0	FRONT STRIP GUIDE	96	
-	2	2168083-1	SCR, SKT HD CAP, RoHS, M3 X 8.0	95	
-	1	318563-1	GUARD, FRONT CHIP	89	
-	1	1-455888-6	SPACER, CRIMPER	82	
-	2	2079383-4	SCR, BHSC, RoHS (M4 X 8)	79	
-	1	1803096-1	EXTENSION PLATE	78	
-	1	1803607-3	DOCUMENTATION PACKAGE	71	
-	1	2119740-1	TAG IDENTIFICATION	67	
-	2	2168078-1	SCREW, DRIVE, RH, RoHS, 2 x .188	66	
-	2	2-18032-5	SCR, SET, FLT PNT, M5 X 20.0	61	
-	1	5-18022-5	SCR, HEX HD CAP, M4 X 6.0	59	
-	1	1338683-8	FEED PAWL	56	
-	1	2168083-9	SCR, SKT HD CAP, RoHS, M4 X 20	53	
-	1	2-2168083-6	SCR, SKT HD CAP, RoHS, M4 X 18	53	
-	1	1803382-2	HOLD DOWN, SPRING LOADED	50	
-	1	18023-9	SCR, SKT HD CAP M4 X 6.0	49	
-	1	1803602-2	SCR, BHSC, RoHS (M8 X 40)	41	
-	1	2-1752356-0	SUPPORT, TERMINAL	34	
-	2	2079383-5	SCR, BHSC, RoHS (M4 X 20)	33	
-	2	2-2844962-0	SPACER, CYLINDRICAL, STRIP GUIDE	30	
-	1	2844992-3	ASSEMBLY, STRIP GUIDE	29	
-	1	1-455888-0	SPACER, CRIMPER	28	
-	2	22283-1	SPRING, COMPRESSION	27	
-	1	356835-1	LEVER, DRAG RELEASE	26	
-	1	240792-1	DRAG, TERMINAL	25	
-	1	1320928-4	STRIP GUIDE	24	
-	1	980371-4	SCR, SKT HD SHLDR 5.0 DIA X 6.0	23	
-	1	2168083-2	SCR, SKT HD CAP, RoHS, M4 X 8.0	21	
-	1	1-18028-2	WASHER, FLAT, REG M4	20	
-	1	2119533-1	STRIPPER, SIDE FEED	19	
-	1	2119806-1	INSERT, SHEAR	13	
-	1	3-22280-3	SPRING, COMPRESSION	12	
-	1	1-356885-4	STOP, SHEAR	11	
-	1	2119805-1	SHEAR HOLDER, FRONT	10	
-	1	318707-1	FLOATING SHEAR, FRONT	9	
-	1	3-1633927-6	ANVIL, COMBINATION	8	
-	1	1-240641-5	SPACER	7	
-	-	-	-	6	
-	1	2119757-8	DEPRESSOR, SHEAR	5	
-	1	1-238011-4	BLOCK, CRIMPER SPACER	4	
-	1	1-1803017-3	CRIMPER, INSULATION F	3	
-	1	1-455888-0	SPACER, CRIMPER	2	
-	1	7-1633609-1	CRIMPER, WIRE	1	
-	77	-22	PART NO	DESCRIPTION	ITEM NO

DIMENSIONS:		TOLERANCES UNLESS OTHERWISE SPECIFIED:		DWN EL GROSS 07FEB2013		TE Connectivity	
mm		0 PLC ±		CHK T. ELBIN 07FEB2013		Harrisburg, PA 17105-3608	
		1 PLC ±		APVD M. CLIFFORD 07FEB2013		NAME	
		2 PLC ±		PRODUCT SPEC		Ocean Side Feed	
		3 PLC ±		APPLICATION SPEC		Applicator	
		4 PLC ±		WEIGHT		SIZE CAGE CODE DRAWING NO	
		ANGLES		A1 00779 C=2151870		RESTRICTED TO	
MATERIAL		FINISH		Customer Accessible Production Drawing		SCALE 1:2 SHEET 3 OF 4 REV B	

LOC		DIST		REVISIONS			
A		66		REV	DATE	BY	APPV
				1	SEE SHEET 1		

FEED TYPE

PNEUMATIC

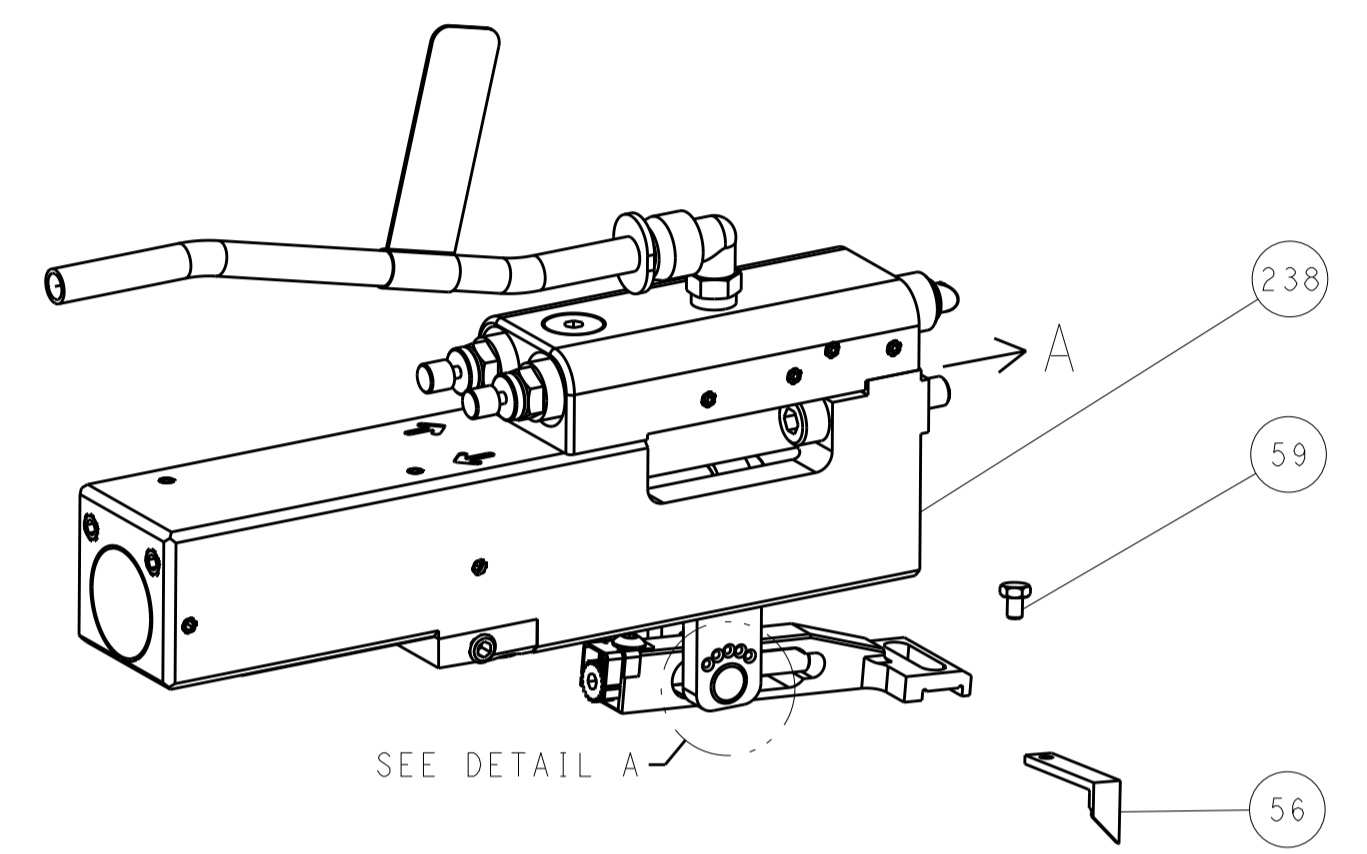

FEED SPRING SETTING POSITION (SHOWN FROM REAR SIDE)

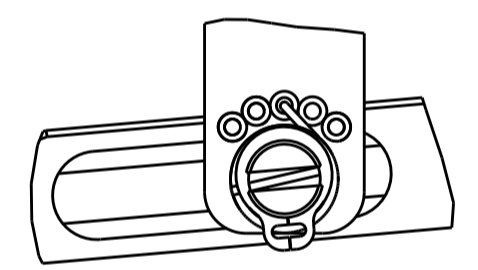

DETAIL A

CAM POSITION

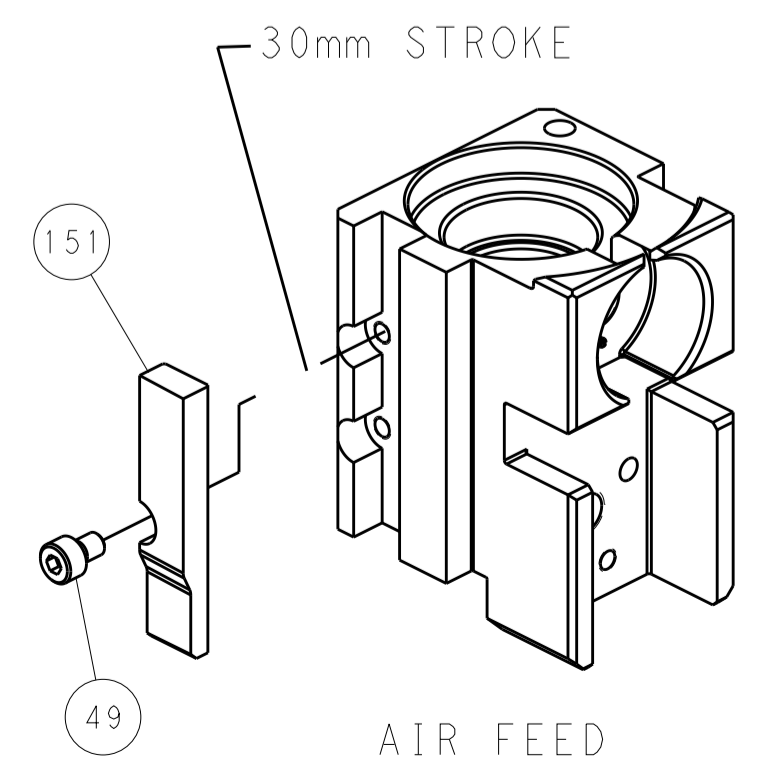

AIR FEED

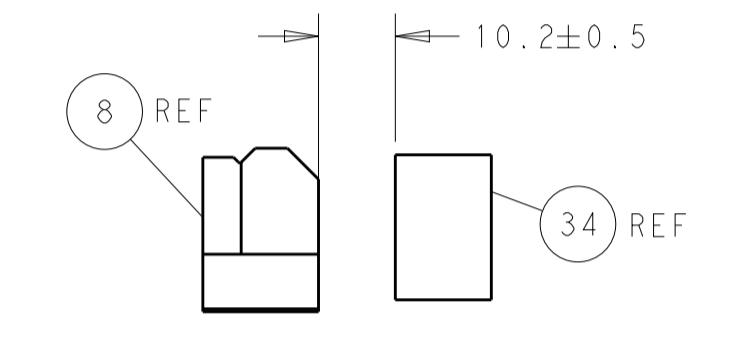
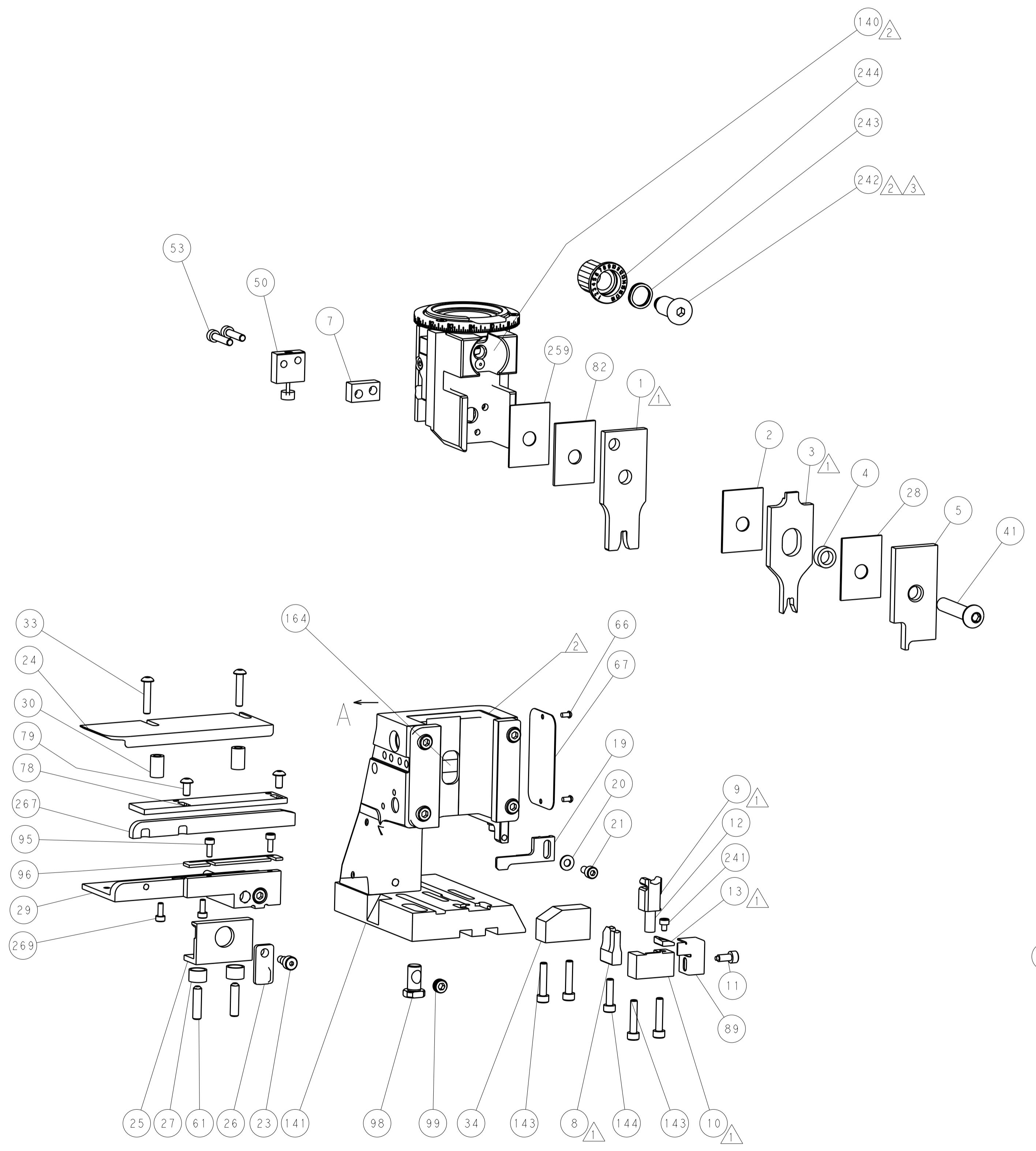

TERMINAL SUPPORT LOCATION

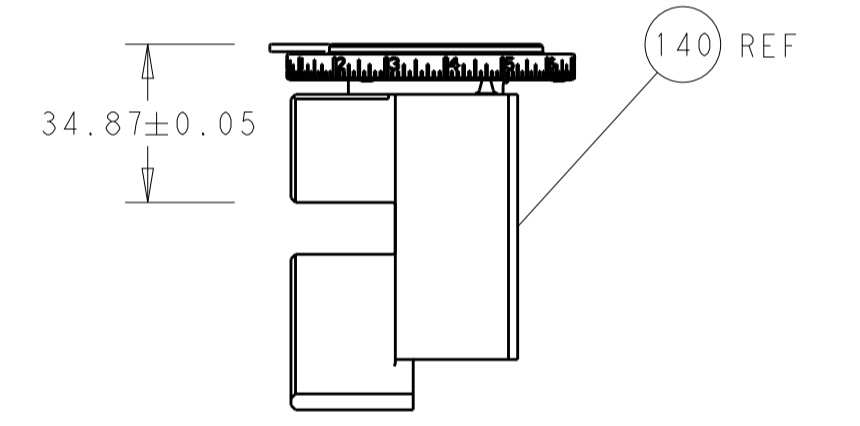

RAM SET-UP

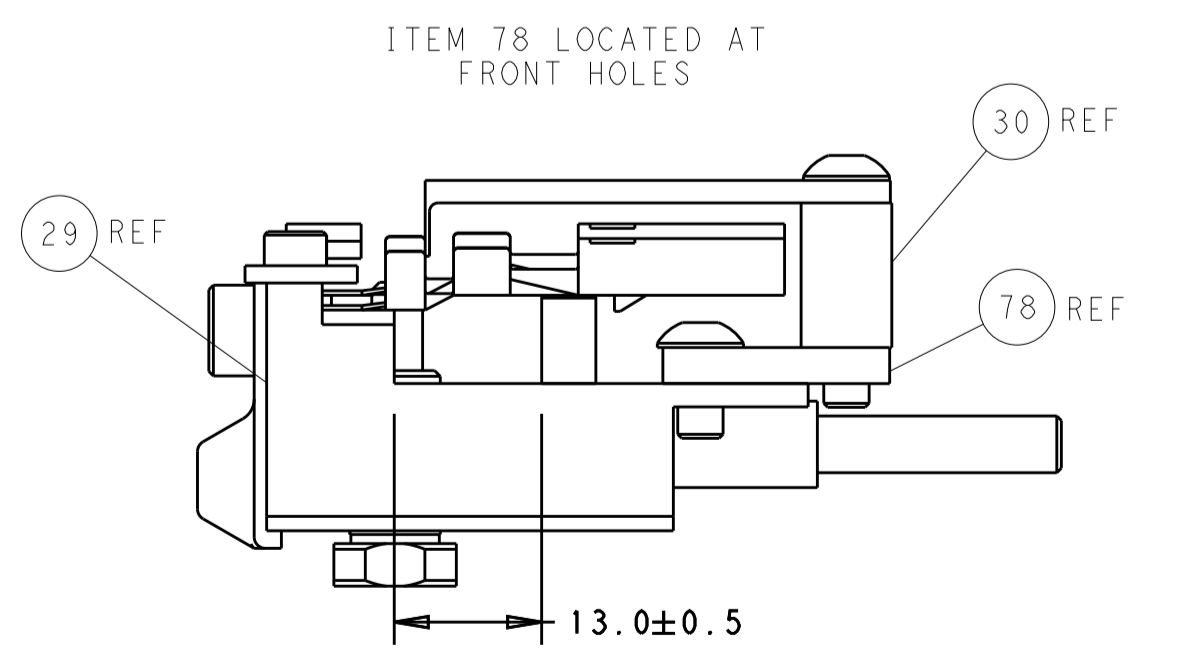

FEED TRACK POSITION GUIDE BY INSULATION BARREL

PACIFIC VERSION
 Shown on sheets 3 of 4 & 4 of 4
 (Atlantic version shown on sheets 1 of 4 & 2 of 4)

DIMENSIONS: mm 		TOLERANCES UNLESS OTHERWISE SPECIFIED: 0 PLC ± 1 PLC ± 2 PLC ± 3 PLC ± 4 PLC ± ANGLES ±		DWN L. GROSS 07FEB2013 CHK T. ELBIN 07FEB2013 APV M. CLIFFORD 07FEB2013 PRODUCT SPEC APPLICATION SPEC WEIGHT Customer Accessible Production Drawing		NAME Ocean Side Feed Applicator SIZE A1 CAGE CODE 00779 DRAWING NO 2151870 SCALE 1:2 SHEET 4 OF 4 REV B		RESTRICTED TO -	
-----------------------	--	---	--	--	--	--	--	--------------------	--