

REVISIONS				
P.	LTN	DESCRIPTION	DATE	APVD
1		ORIGINAL	21JUN2019	BKW CY
2		MINOR GEOMETRY CHANGES	19AUG2019	BKW CY
3		MINOR GEOMETRY CHANGES	16SEP2019	BKW CY

- ⚠ MATERIAL: PA66, GLASS FILLED, COLOR: SEE TABLE
- ⚠ MATERIAL MARK: PA66 GF
- ⚠ KEYING ID MARK
- 4. APPLICABLE CONTACT P/N:
2350223-*
- 5. MATING CONNECTOR P/N
T/H HEADER: *-2232826-**
SMT HEADER: *-2232979-**
TPA: 2357686-*
- 6. PRELIMINARY PART - NOT RELEASED FOR PRODUCTION
THIS PRODUCT HAS NOT COMPLETED QUALIFICATION TESTING.

DIM "C"	DIM "B"	DIM "A"	COLOR	KEYING	POSITIONS	PART NUMBER
22.25	20.55	6.90	TBD	KEY E	1*10	6-2350224-0
20.25	18.55	6.90	TBD	KEY E	1*9	5-2350224-9
18.25	16.55	6.90	TBD	KEY E	1*8	5-2350224-8
16.25	14.55	6.90	TBD	KEY E	1*7	5-2350224-7
14.25	12.55	6.90	TBD	KEY E	1*6	5-2350224-6
12.25	10.55	6.90	TBD	KEY E	1*5	5-2350224-5
10.25	8.55	6.90	TBD	KEY E	1*4	5-2350224-4
8.25	6.55	7.30	TBD	KEY E	1*3	5-2350224-3
6.25	4.55	5.30	TBD	KEY E	1*2	5-2350224-2
22.25	20.55	6.90	TBD	KEY D	1*10	5-2350224-0
20.25	18.55	6.90	TBD	KEY D	1*9	4-2350224-9
18.25	16.55	6.90	TBD	KEY D	1*8	4-2350224-8
16.25	14.55	6.90	TBD	KEY D	1*7	4-2350224-7
14.25	12.55	6.90	TBD	KEY D	1*6	4-2350224-6
12.25	10.55	6.90	TBD	KEY D	1*5	4-2350224-5
10.25	8.55	6.90	TBD	KEY D	1*4	4-2350224-4
8.25	6.55	7.30	TBD	KEY D	1*3	4-2350224-3
6.25	4.55	5.30	TBD	KEY D	1*2	4-2350224-2
22.25	20.55	6.90	TBD	KEY C	1*10	4-2350224-0
20.25	18.55	6.90	TBD	KEY C	1*9	3-2350224-9
18.25	16.55	6.90	TBD	KEY C	1*8	3-2350224-8
16.25	14.55	6.90	TBD	KEY C	1*7	3-2350224-7
14.25	12.55	6.90	TBD	KEY C	1*6	3-2350224-6
12.25	10.55	6.90	TBD	KEY C	1*5	3-2350224-5
10.25	8.55	6.90	TBD	KEY C	1*4	3-2350224-4
8.25	6.55	7.30	TBD	KEY C	1*3	3-2350224-3
6.25	4.55	5.30	TBD	KEY C	1*2	3-2350224-2
22.25	20.55	6.90	BLACK	KEY B	1*10	3-2350224-0
20.25	18.55	6.90	BLACK	KEY B	1*9	2-2350224-9
18.25	16.55	6.90	BLACK	KEY B	1*8	2-2350224-8
16.25	14.55	6.90	BLACK	KEY B	1*7	2-2350224-7
14.25	12.55	6.90	BLACK	KEY B	1*6	2-2350224-6
12.25	10.55	6.90	BLACK	KEY B	1*5	2-2350224-5
10.25	8.55	6.90	BLACK	KEY B	1*4	2-2350224-4
8.25	6.55	7.30	BLACK	KEY B	1*3	2-2350224-3
6.25	4.55	5.30	BLACK	KEY B	1*2	2-2350224-2
22.25	20.55	6.90	NATURAL	KEY A	1*10	2-2350224-0
20.25	18.55	6.90	NATURAL	KEY A	1*9	1-2350224-9
18.25	16.55	6.90	NATURAL	KEY A	1*8	1-2350224-8
16.25	14.55	6.90	NATURAL	KEY A	1*7	1-2350224-7
14.25	12.55	6.90	NATURAL	KEY A	1*6	1-2350224-6
12.25	10.55	6.90	NATURAL	KEY A	1*5	1-2350224-5
10.25	8.55	6.90	NATURAL	KEY A	1*4	1-2350224-4
8.25	6.55	7.30	NATURAL	KEY A	1*3	1-2350224-3
6.25	4.55	5.30	NATURAL	KEY A	1*2	1-2350224-2

THIS DRAWING IS A CONTROLLED DOCUMENT.

DIMENSIONS: mm

TOLERANCES UNLESS OTHERWISE SPECIFIED:

0 PLC	±
1 PLC	±
2 PLC	±
3 PLC	±
4 PLC	±
ANGLES	±
FINISH	-

MATERIAL: ⚠

APPROVED: B. WEAVER, 21JUN2019

DESIGNED: C. YI, 21JUN2019

PRODUCT SPEC: T. BENCHOFF, 21JUN2019

APPLICATION SPEC: -

WEIGHT: -

CUSTOMER DRAWING

NAME: PLUG HOUSING, SGI 2.0

SIZE: A | CAGE CODE: 00779 | DRAWING NO: 2350224

RESTRICTED TO: -

SCALE: 12:1 | SHEET 1 OF 3 | REV 4

REVISIONS				
P.	LTN	DESCRIPTION	DATE	APVD
-	SEE SHEET 1			

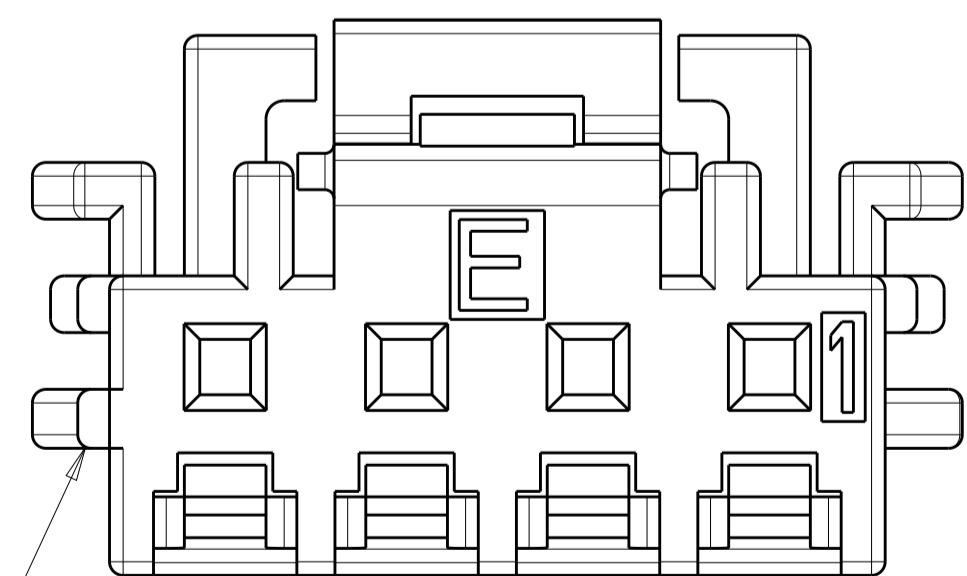
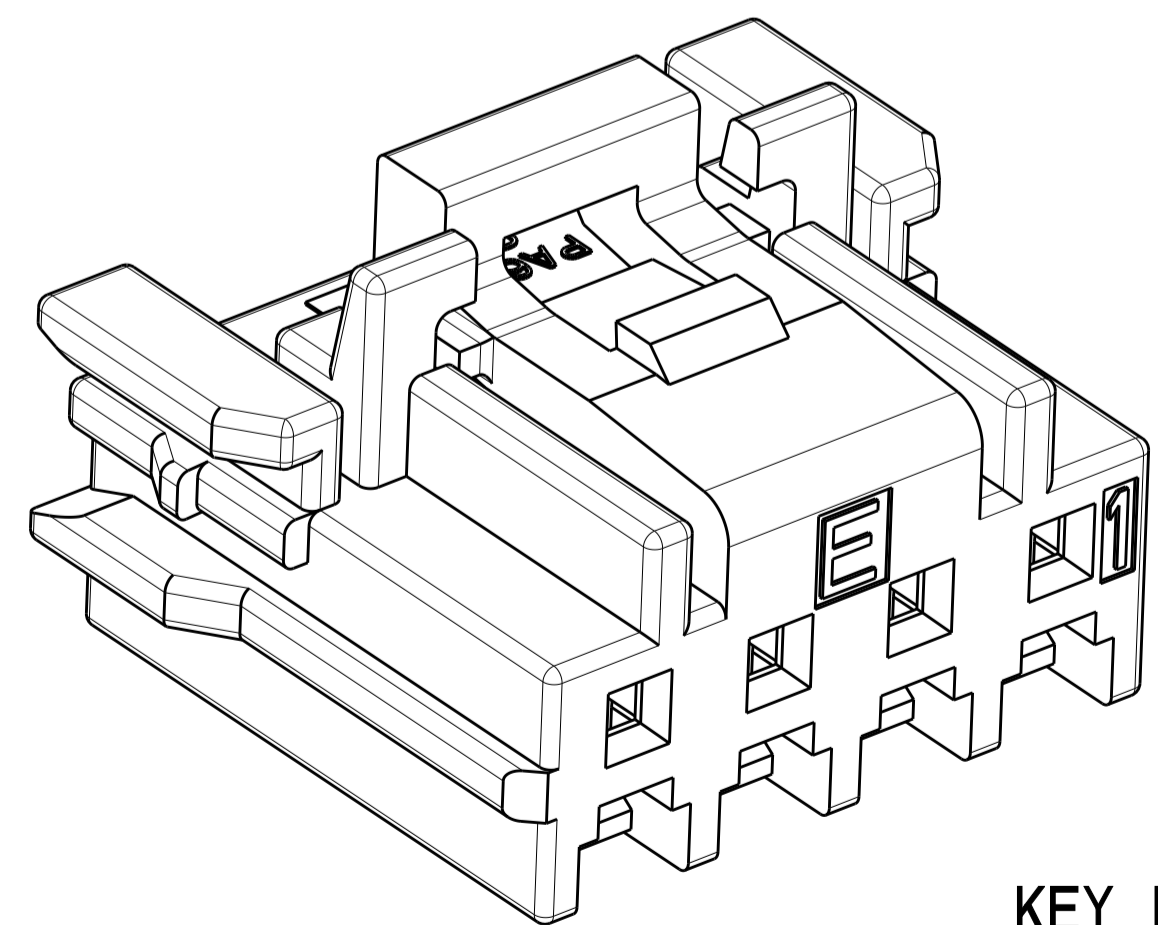
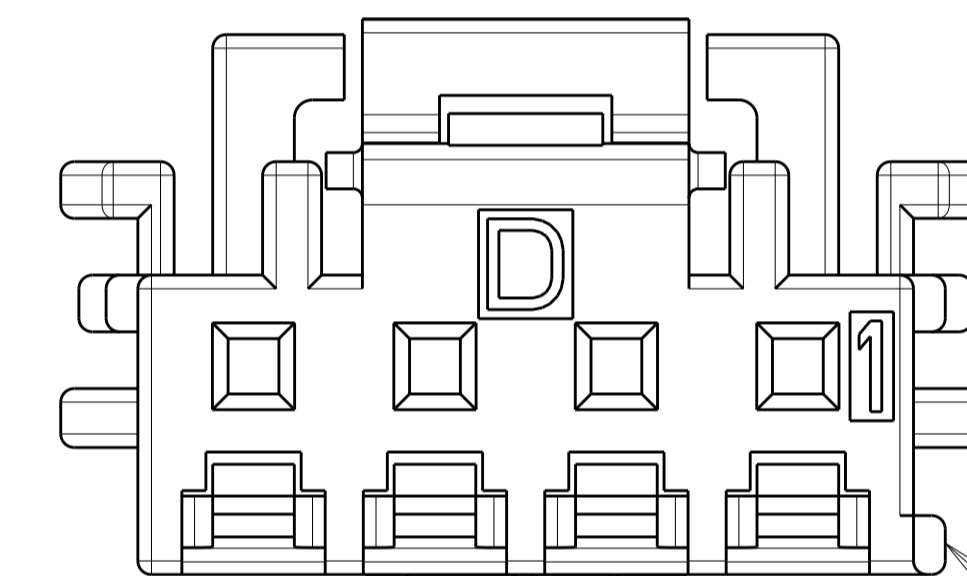
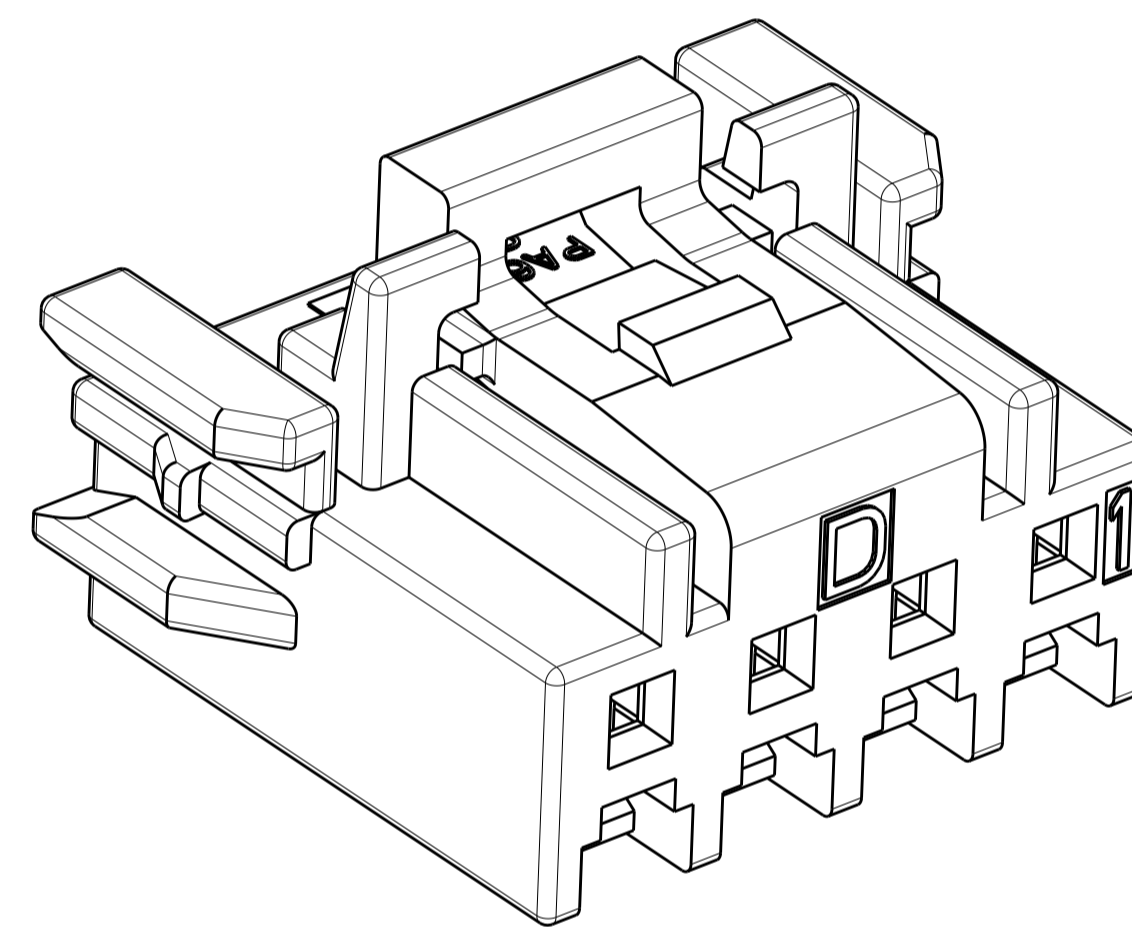
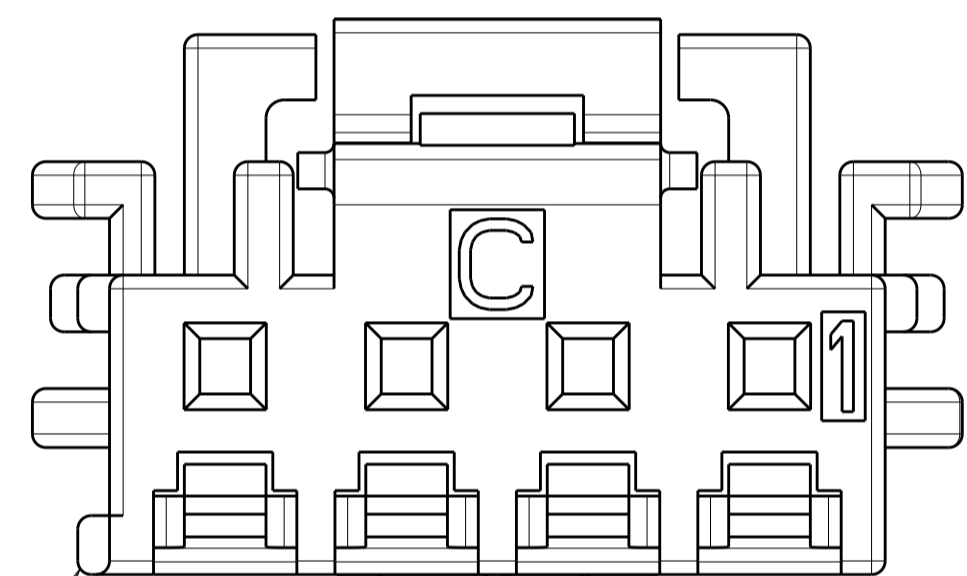
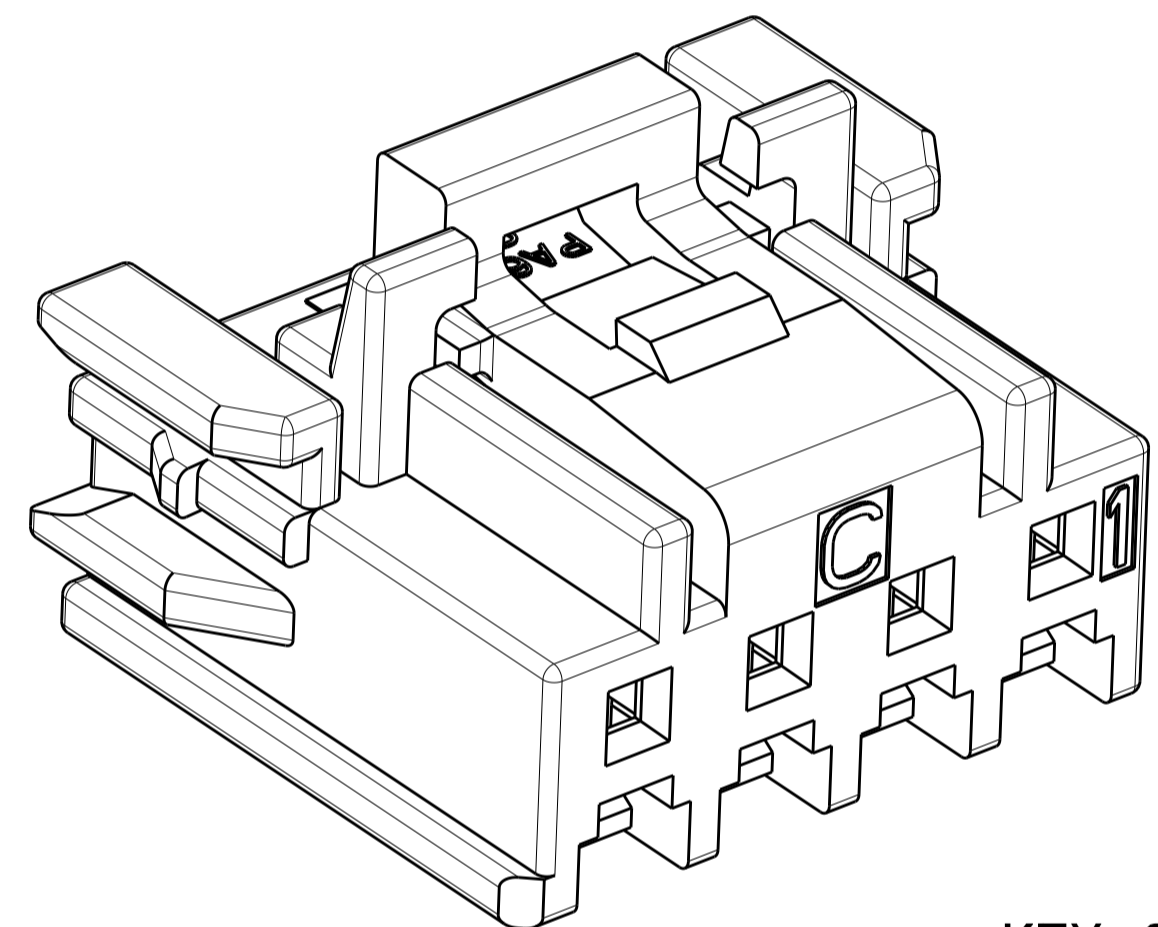
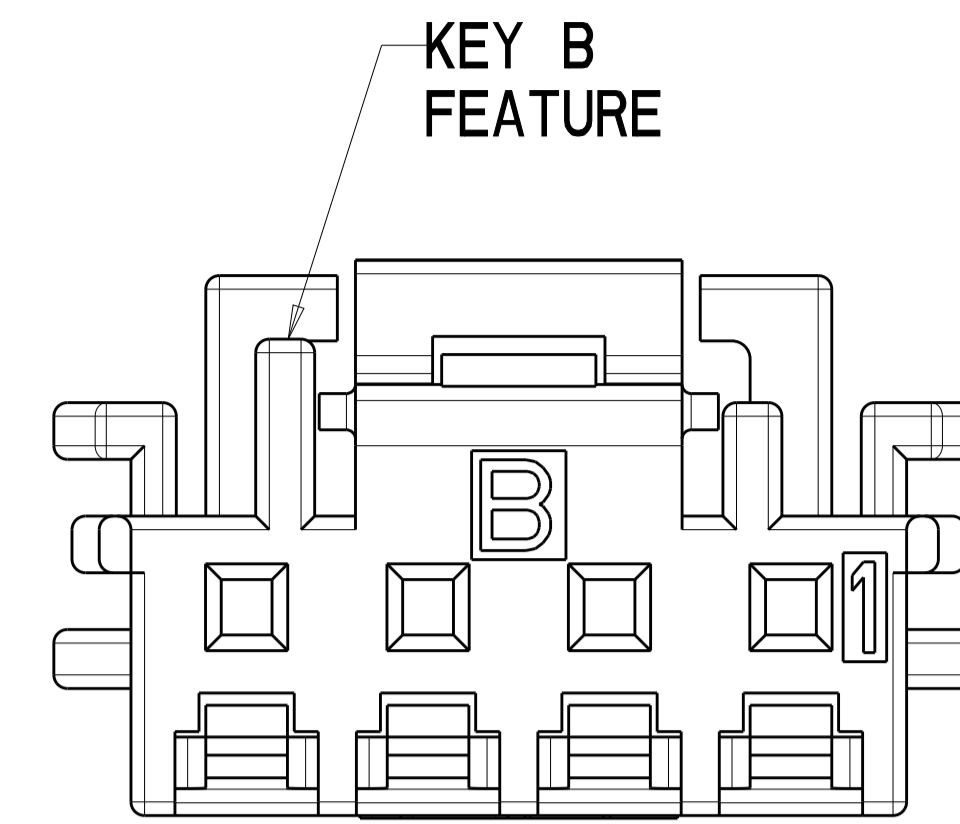
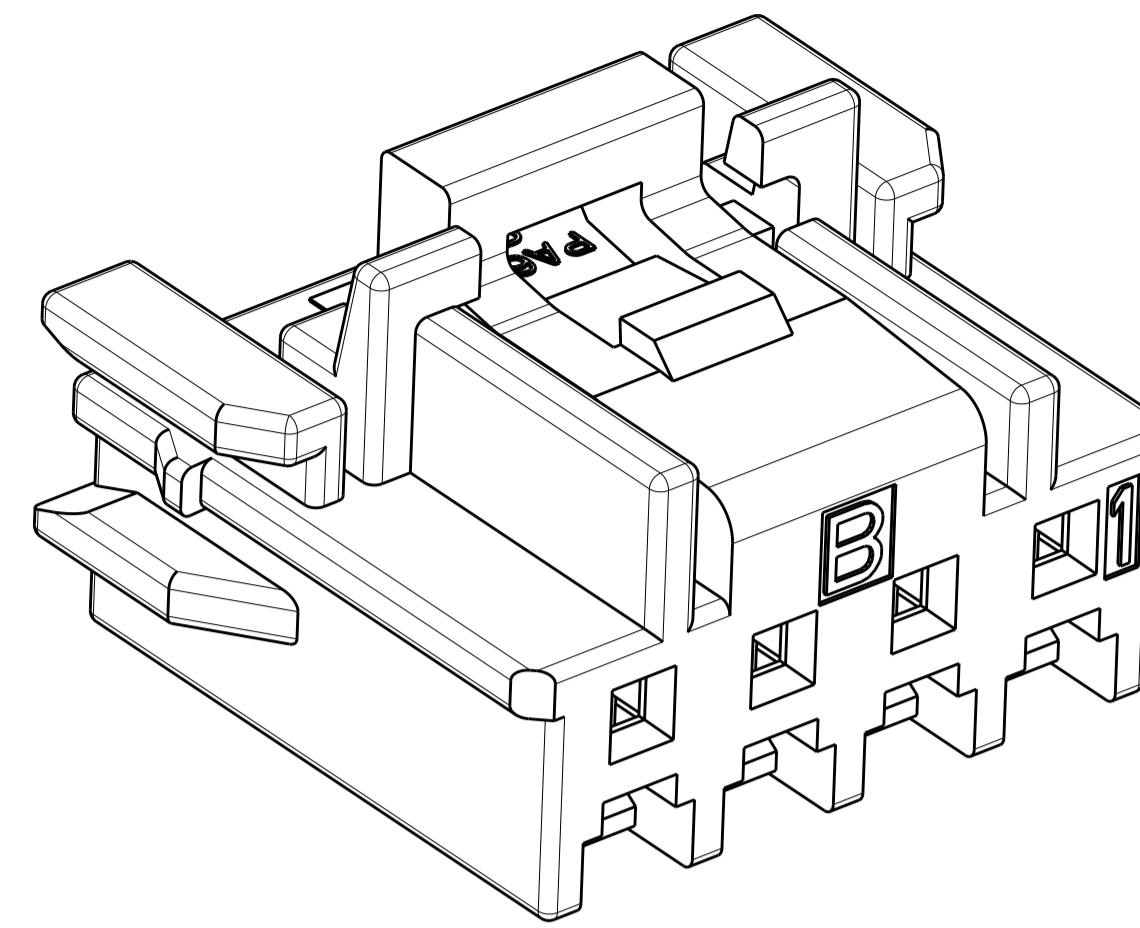
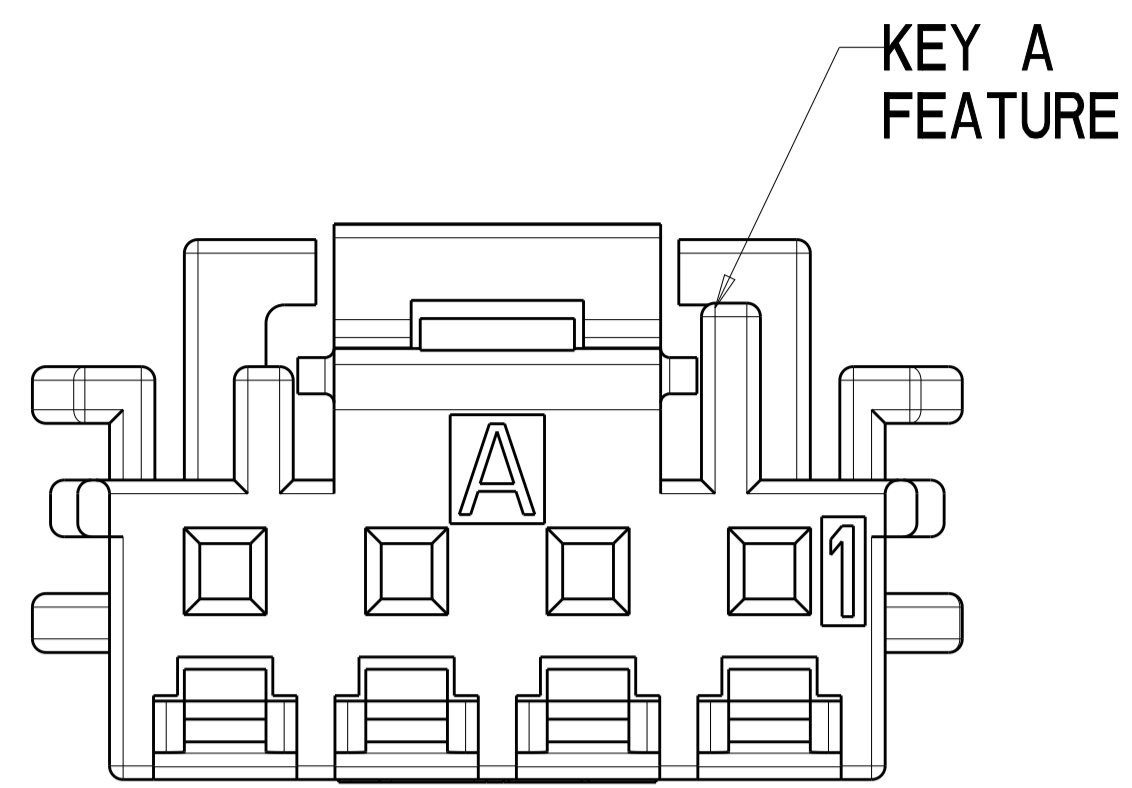
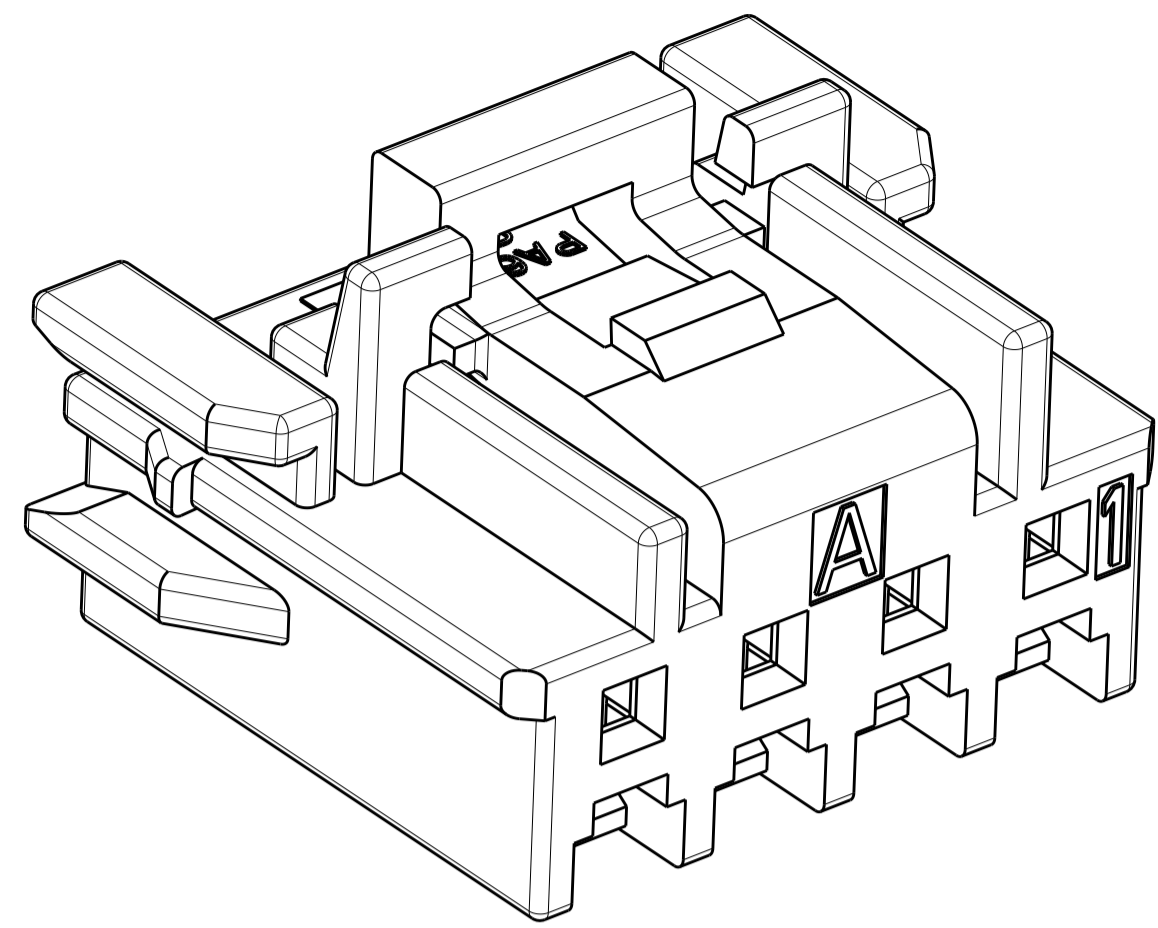

THIS DRAWING IS A CONTROLLED DOCUMENT.		DWN: B. WEAVER 21JUN2019 CHK: C. YI 21JUN2019 APVD: T. BENCHOFF 21JUN2019	TE Connectivity	
DIMENSIONS: mm 	TOLERANCES UNLESS OTHERWISE SPECIFIED: 0 PLC ± 1 PLC ± 2 PLC ± 3 PLC ± 4 PLC ± ANGLES ±	NAME: PLUG HOUSING, SGI 2.0 PRODUCT SPEC: APPLICATION SPEC:	SIZE: A CAGE CODE: 00779 DRAWING NO: 2350224	RESTRICTED TO:
MATERIAL:	FINISH:	WEIGHT:	CUSTOMER DRAWING	SCALE: 12:1 SHEET: 2 OF 3 REV: 4

REVISIONS				
P.	LTN	DESCRIPTION	DATE	APVD
-	-	SEE SHEET 1	-	-

2 POSITION

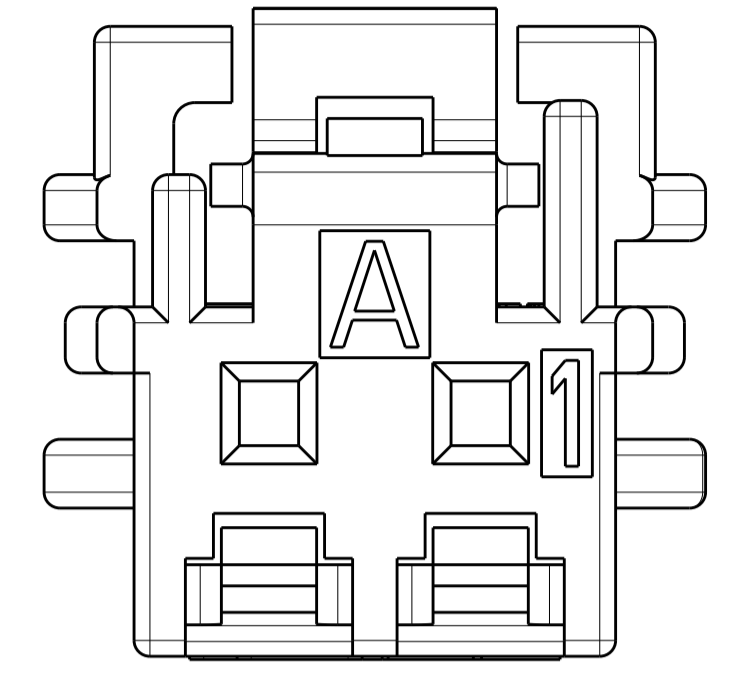

3 POSITION

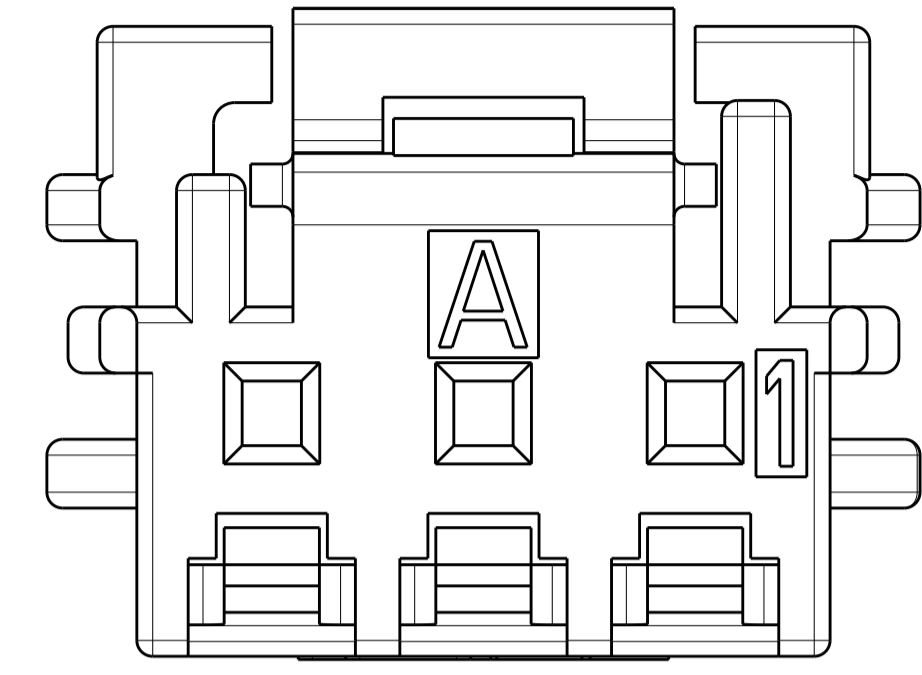

4 POSITION

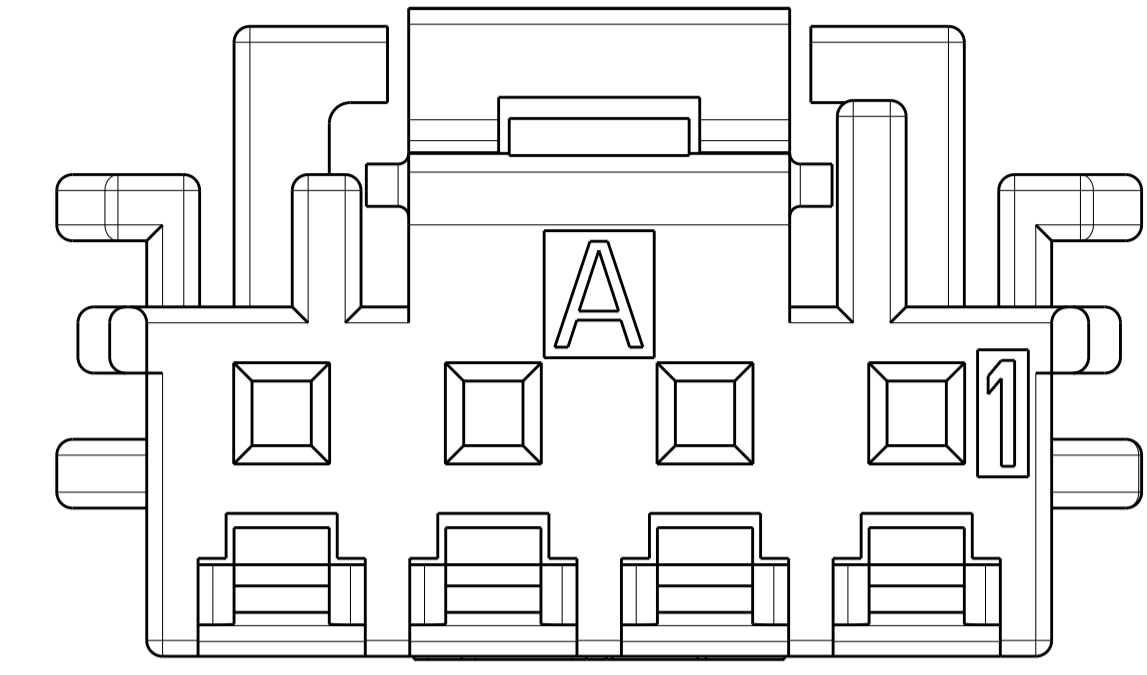

5 POSITION

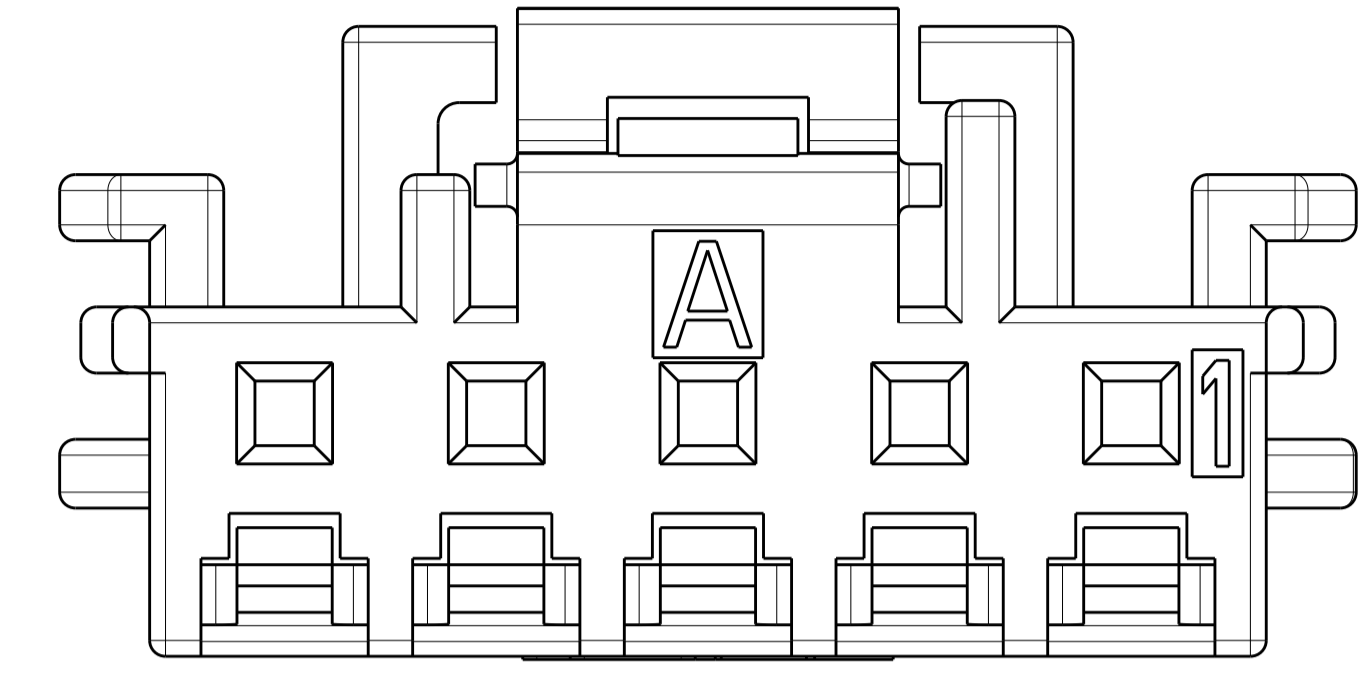

6 POSITION

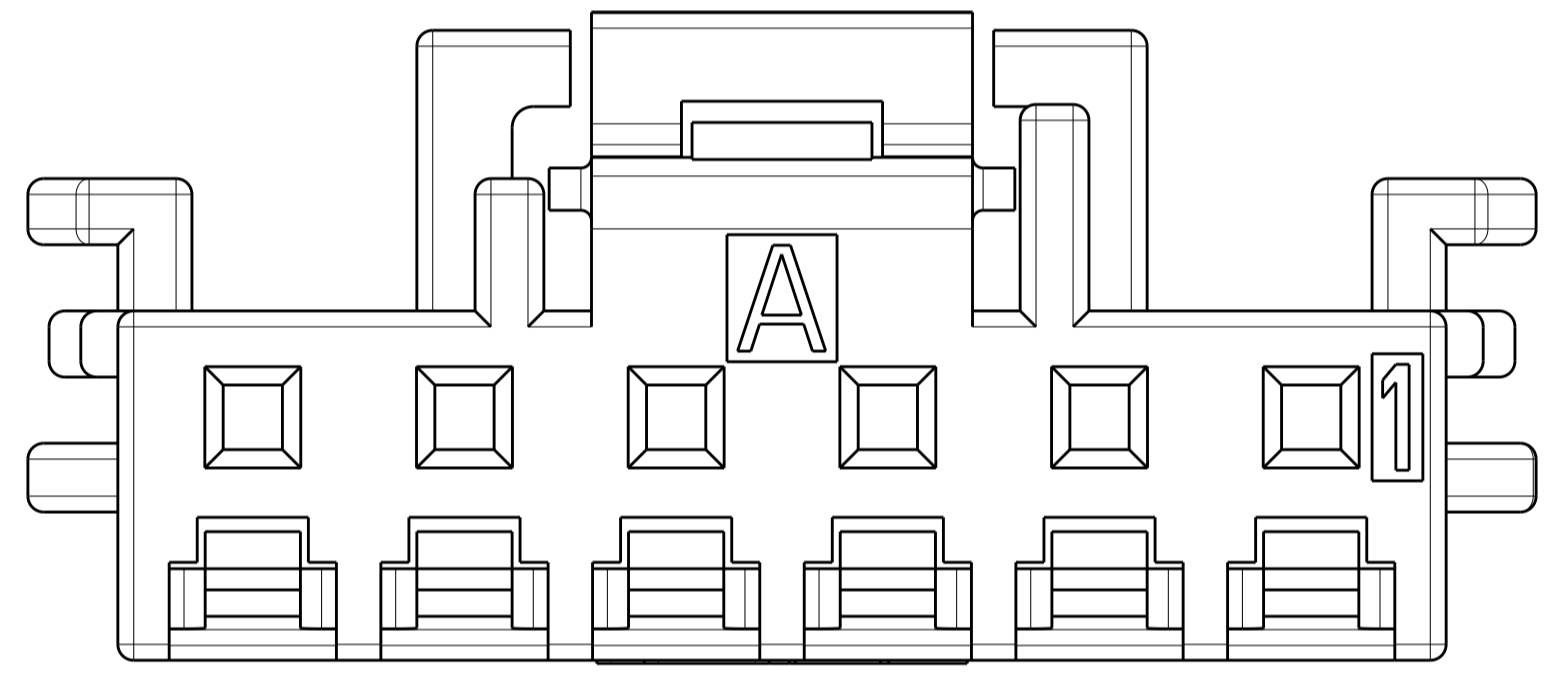

7 POSITION

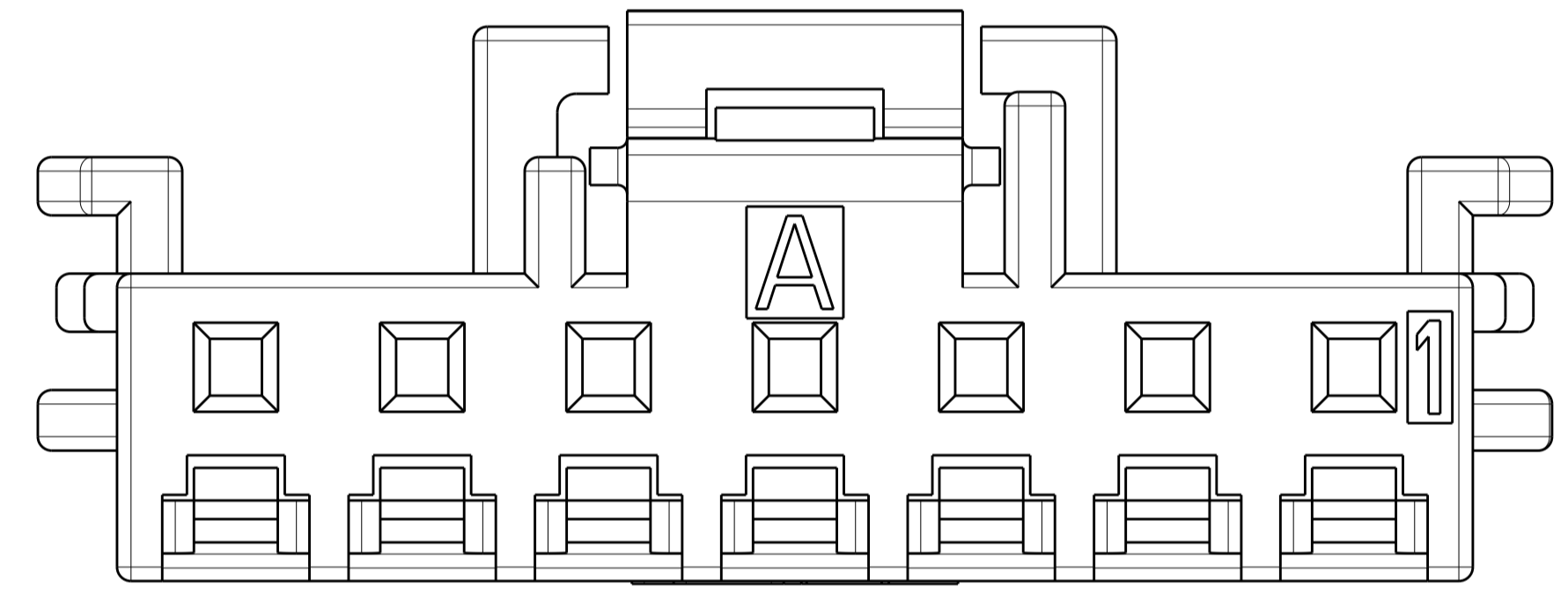

8 POSITION

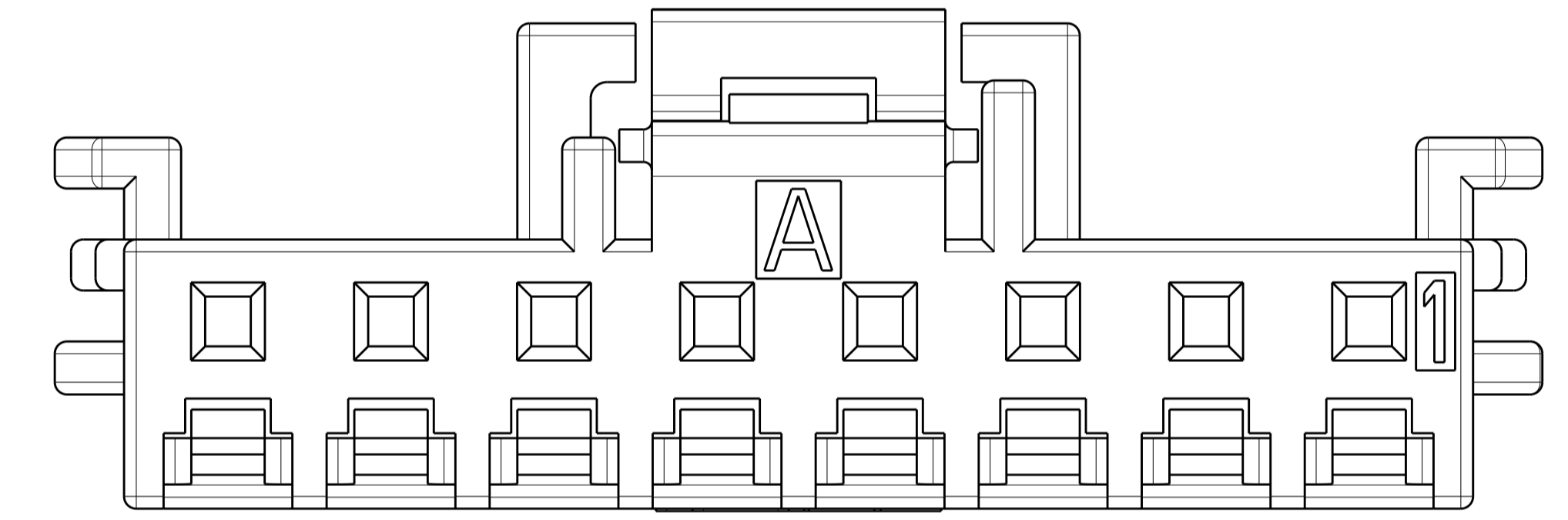

9 POSITION

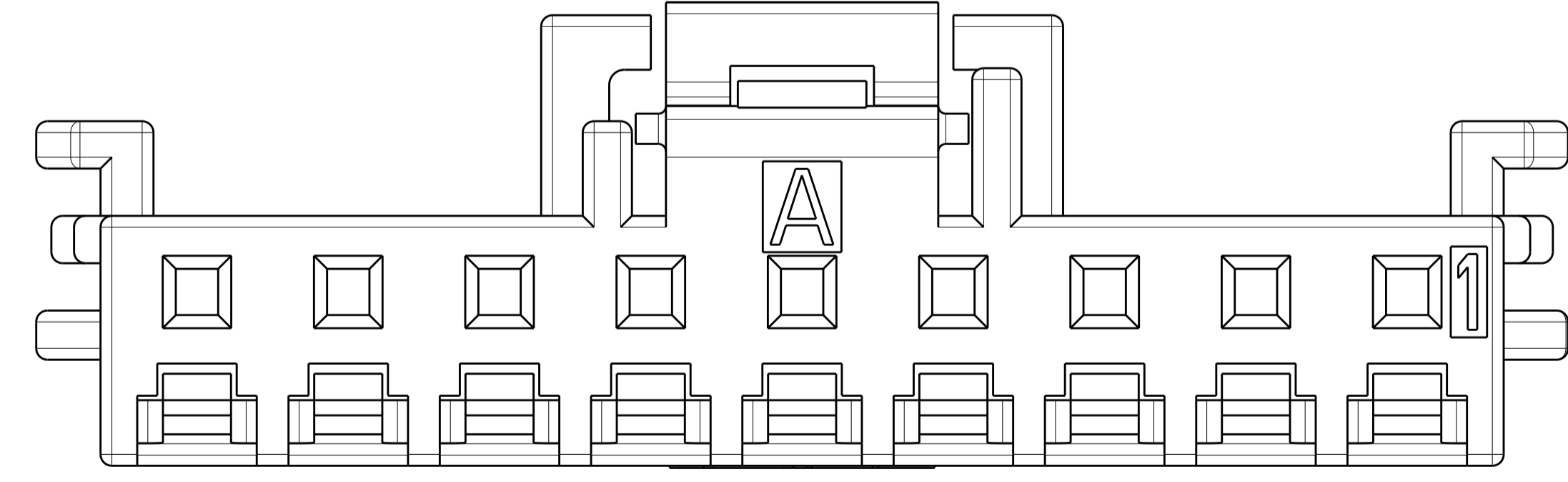

10 POSITION

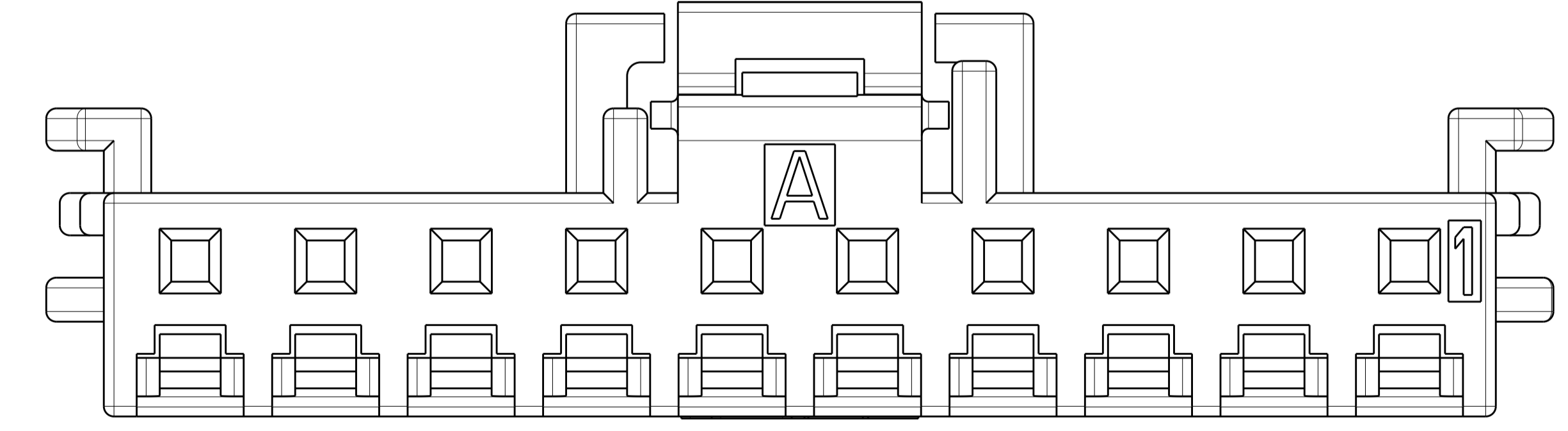

THIS DRAWING IS A CONTROLLED DOCUMENT.		DWN: B. WEAVER 21JUN2019 CHK: C. YI 21JUN2019 APVD: T. BENCHOFF 21JUN2019	
DIMENSIONS: mm	TOLERANCES UNLESS OTHERWISE SPECIFIED: 0 PLC ± 1 PLC ± 2 PLC ± 3 PLC ± 4 PLC ± ANGLES ±	NAME: PLUG HOUSING, SGI 2.0 PRODUCT SPEC: APPLICATION SPEC: WEIGHT: CUSTOMER DRAWING	
MATERIAL: FINISH:	WEIGHT: CUSTOMER DRAWING	SIZE: A1 CAGE CODE: 00779 DRAWING NO: 2350224	RESTRICTED TO: SCALE: 12:1 SHEET: 3 OF 3 REV: 4