

SN54AS870, SN54AS871, SN74AS870, SN74AS871 DUAL 16-BY-4 REGISTER FILES

D2661, DECEMBER 1982—REVISED JANUARY 1986

- 'AS870 in 24-Pin Small Outline, 300-mil DIP and Both Plastic and Ceramic 28-Pin Chip Carriers
- 'AS871 in 28-Pin 600-mil DIP and Both Plastic and Ceramic Chip Carriers
- 3-State Buffer-Type Outputs Drive Bus Lines Directly
- Typical Access Time is 11 ns
- Each Register File Has Individual Write Enable Controls and Address Lines
- Designed Specifically for Multibus Architecture and Overlapping File Operations
- Prioritized B Input Port Prevents Write Conflicts During Dual Input Mode
- Dependable Texas Instruments Quality and Reliability

description

These devices feature two 16-word by 4-bit register files. Each register file has individual write-enable controls and address lines. The 'AS870 has two 4-bit data I/O ports (DQA1-DQA4 and DQB1-DQB4). The 'AS871 has one 4-bit data I/O port (DQB1-DQB4) with the other data port having individual data inputs (DA1-DA4) and data outputs (QA1-QA4). The data I/O ports can output to Bus A and Bus B, receive input from Bus A and Bus B, receive input from Bus A and output to Bus B, or output to Bus A and receive input from Bus B. To prevent writing conflicts in the dual-input mode, the B input port takes priority. Two select lines, S0 and S1, control which port has access to which register. S2 determines whether the A ports are in the input or the output modes and S3 does likewise for the B ports. The address lines (1A0-1A3 or 2A0-2A3) are decoded by an internal 1-of-16 decoder to select which register word is to be accessed. All outputs are 3-state buffer-type outputs designed specifically to drive bus lines directly.

The SN54AS870 and SN54AS871 are characterized for operation over the full military temperature range of -55°C to 125°C. The SN74AS870 and SN74AS871 are characterized for operation from 0°C to 70°C.

SN54AS870 . . . JT PACKAGE
SN74AS870 . . . DW OR NT PACKAGE

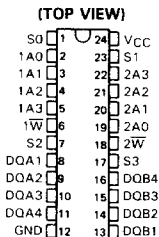

SN54AS871 . . . JD PACKAGE
SN74AS871 . . . N PACKAGE

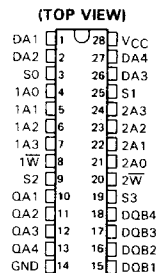

SN54AS870 . . . FK PACKAGE
SN74AS870 . . . FN PACKAGE

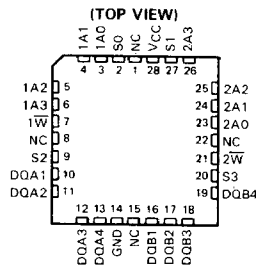

SN54AS871 . . . FK PACKAGE
SN74AS871 . . . FN PACKAGE

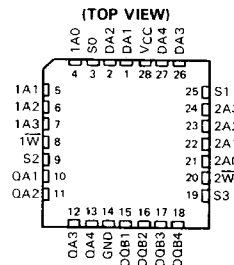

NC—No internal connection

PRODUCTION DATA documents contain information current as of publication date. Products conform to specifications per the terms of Texas Instruments standard warranty. Production processing does not necessarily include testing of all parameters.

**TEXAS
INSTRUMENTS**

POST OFFICE BOX 225012 • DALLAS, TEXAS 75265

Copyright © 1982, Texas Instruments Incorporated

2-219

2

LSI Devices

SN54AS870, SN54AS871, SN74AS870, SN74AS871
DUAL 16-BY-4 REGISTER FILES

logic symbols†

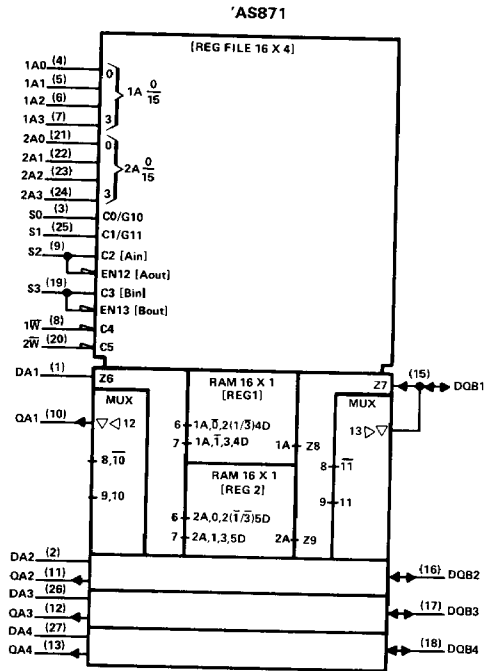
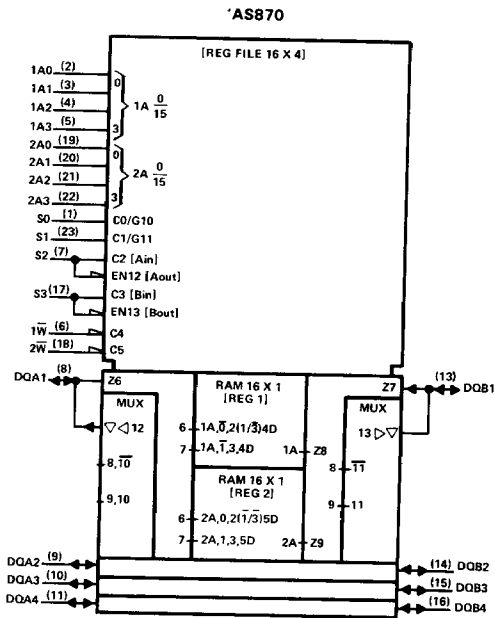

† These symbols are in accordance with ANSI/IEEE Std 91-1984 and IEC Publication 617-12.

Pin numbers shown are for DW, JT, and NT packages.

2
LSI Devices

SN54AS870, SN54AS871, SN74AS870, SN74AS871
DUAL 16-BY-4 REGISTER FILES

logic diagram (positive logic)

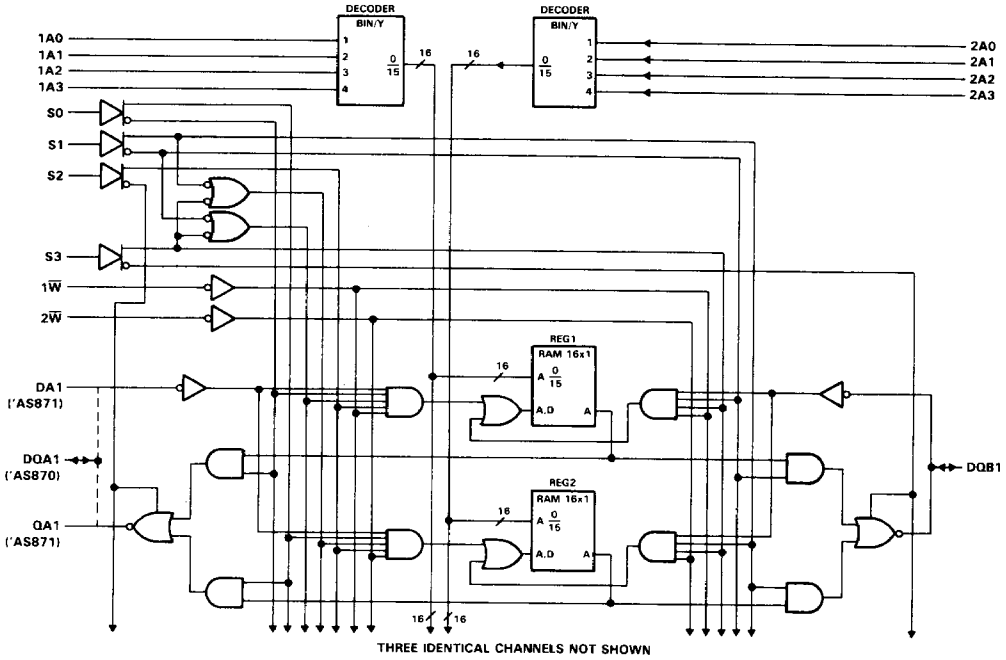

2
LSI Devices

**SN54AS870, SN54AS871, SN74AS870, SN74AS871
DUAL 16-BY-4 REGISTER FILES**

FUNCTION TABLE

FILE SELECT			INPUT/OUTPUT		
S0	S1	FILE SEL	S2	S3	I/O SEL
L	L	1R TO A, 1R TO B	L	L	A OUT, B OUT
H	L	2R TO A, 1R TO B			
L	H	1R TO A, 2R TO B			
H	H	2R TO A, 2R TO B			
L	L	A TO 1R, 1R TO B	H	L	A IN, B OUT
H	L	A TO 2R, 1R TO B			
L	H	A TO 1R, 2R TO B			
H	H	A TO 2R, 2R TO B			
L	L	1R TO A, B TO 1R	L	H	A OUT, B IN
H	L	2R TO A, B TO 1R			
L	H	1R TO A, B TO 2R			
H	H	2R TO A, B TO 2R			
L	L	B TO 1R	H	H	A IN, B IN
H	L	A TO 2R, B TO 1R			
L	H	A TO 1R, B TO 2R			
H	H	B TO 2R			

2

LSI Devices

absolute maximum ratings over operating free-air temperature range (unless otherwise noted)

Supply voltage, VCC	7 V
Input voltage: All inputs	7 V
I/O ports	5.5 V
Voltage applied to a disabled 3-state output	5.5 V
Operating free-air temperature range: SN54AS870, SN54AS871	-55°C to 125°C
SN74AS870, SN74AS871	0°C to 70°C
Storage temperature range	-65°C to 150°C

recommended operating conditions

		SN54AS870 SN54AS871			SN74AS870 SN74AS871			UNIT
		MIN	NOM	MAX	MIN	NOM	MAX	
VCC	Supply voltage	4.5	5	5.5	4.5	5	5.5	V
V _{IH}	High-level input voltage	2			2			V
V _{IL}	Low-level input voltage			0.8			0.8	V
I _{OH}	High-level output current			-12			-15	mA
I _{OL}	Low-level output current			32			48	mA
t _w	Duration of write pulse	12			12			ns
t _{su}	Setup times	Address before write↓	5		5			ns
		Data before write↑	15		15			
		Select before write↓	12		12			
t _h	Hold times	Address after write↑	0		0		ns	
		Data after write↑	0		0			
		Select after write↑	12		12			
T _A	Operating free-air temperature	-55		125	0		70	°C

**SN54AS870, SN54AS871, SN74AS870, SN74AS871
DUAL 16-BY-4 REGISTER FILES**

***AS870 electrical characteristics over recommended operating free-air temperature range (unless otherwise noted)**

PARAMETER	TEST CONDITIONS	SN54AS870			SN74AS870			UNIT
		MIN	TYP [†]	MAX	MIN	TYP [†]	MAX	
V _{IK}	V _{CC} = 4.5 V, I _I = -18 mA			-1.2			-1.2	V
V _{OH}	V _{CC} = 4.5 V to 5.5 V, I _{OH} = -2 mA	V _{CC} 2			V _{CC} 2			V
	V _{CC} = 4.5 V, I _{OH} = -12 mA	2.4	3.2					
	V _{CC} = 4.5 V, I _{OH} = -15 mA				2.4	3.2		
V _{OL}	V _{CC} = 4.5 V, I _{OL} = 32 mA		0.25	0.5				V
	V _{CC} = 4.5 V, I _{OL} = 48 mA						0.35 0.5	
I _I	Control inputs	V _{CC} = 5.5 V, V _I = 7 V						mA
	DQA and DQB ports	V _{CC} = 5.5 V, V _I = 5.5 V						
I _{IH}	1W and 2W				20			μA
	Other control inputs	V _{CC} = 5.5 V, V _I = 2.7 V			40			
	DQA and DQB ports [‡]				50			
I _{IL}	Control inputs	V _{CC} = 5.5 V, V _I = 0.4 V			-2			mA
	DQA and DQB ports [‡]				-2			
I _O [§]	V _{CC} = 5.5 V, V _O = 2.25 V	-30		-112	-30		-112	mA
I _{CC}	V _{CC} = 5.5 V		120	190		120	190	mA

***AS871 electrical characteristics over recommended operating free-air temperature range (unless otherwise noted)**

PARAMETER	TEST CONDITIONS	SN54AS871			SN74AS871			UNIT
		MIN	TYP [†]	MAX	MIN	TYP [†]	MAX	
V _{IK}	V _{CC} = 4.5 V, I _I = -18 mA			-1.2			-1.2	V
V _{OH}	V _{CC} = 4.5 V to 5.5 V, I _{OH} = -2 mA	V _{CC} 2			V _{CC} 2			V
	V _{CC} = 4.5 V, I _{OH} = -12 mA	2.4	3.2					
	V _{CC} = 4.5 V, I _{OH} = -15 mA				2.4	3.2		
V _{OL}	V _{CC} = 4.5 V, I _{OL} = 32 mA		0.25	0.5				V
	V _{CC} = 4.5 V, I _{OL} = 48 mA						0.35 0.5	
I _{OZH}	QA outputs	V _{CC} = 5.5 V, V _O = 2.7 V			50			μA
I _{OZL}	QA outputs	V _{CC} = 5.5 V, V _O = 0.4 V			-50			μA
I _I	Control and DA inputs	V _{CC} = 5.5 V, V _I = 7 V			0.1			mA
	DQB ports	V _{CC} = 5.5 V, V _I = 5.5 V			0.2			
I _{IH}	1W, 2W, and DA inputs				20			μA
	Other control inputs	V _{CC} = 5.5 V, V _I = 2.7 V			40			
	DQB ports [‡]				50			
I _{IL}	Control and DA inputs	V _{CC} = 5.5 V, V _I = 0.4 V			-2			mA
	DQB ports [‡]				-2			
I _O [§]	V _{CC} = 5.5 V, V _O = 2.25 V	-30		112	-30		-112	mA
I _{CC}	V _{CC} = 5.5 V		120	190		120	190	mA

[†]All typical values are at V_{CC} = 5 V, T_A = 25°C.

[‡]For I/O ports, the parameters I_{IH} and I_{IL} include the off-state output current.

[§]The output conditions have been chosen to produce a current that closely approximates one-half of the true short-circuit current, I_{OS}.

2

LSI Devices

SN54AS870, SN54AS871, SN74AS870, SN74AS871
DUAL 16-BY-4 REGISTER FILES

'AS870 switching characteristics (see Note 1)

PARAMETER	FROM (INPUT)	TO (OUTPUT)	$V_{CC} = 4.5 \text{ V to } 5.5 \text{ V,}$ $C_L = 50 \text{ pF,}$ $R_1 = 500 \Omega,$ $R_2 = 500 \Omega,$ $T_A = \text{MIN to MAX}$				UNIT
			SN54AS870		SN74AS870		
			MIN	MAX	MIN	MAX	
$t_{a(A)}$	Any A	Any DQ	5	20	5	15	ns
$t_{a(S)}$	S0	Any DQA	3	15	3	13	ns
	S1	Any DQB	3	15	3	13	
t_{dis}	S2	Any DQA	3	12	3	11	ns
	S3	Any DQB	3	12	3	11	
t_{en}	S2	Any DQA	3	15	3	12	ns
	S3	Any DQB	3	15	3	12	
t_{pd}	\overline{W}	Any DQ	5	23	5	19	ns
	DQA	DQB	5	25	5	22	
	DQB	DQA	5	25	5	22	

2

LSI Devices

'AS871 switching characteristics (see Note 1)

PARAMETER	FROM (INPUT)	TO (OUTPUT)	$V_{CC} = 4.5 \text{ V to } 5.5 \text{ V,}$ $C_L = 50 \text{ pF,}$ $R_1 = 500 \Omega,$ $R_2 = 500 \Omega,$ $T_A = \text{MIN to MAX}$				UNIT
			SN54AS871		SN74AS871		
			MIN	MAX	MIN	MAX	
$t_{a(A)}$	Any A	Any QA or DQB	5	20	5	16	ns
$t_{a(S)}$	S0	Any QA	3	15	3	13	ns
	S1	Any DQB	3	15	3	13	
t_{dis}	S2	Any QA	3	12	3	11	ns
	S3	Any DQB	3	12	3	11	
t_{en}	S2	Any QA	3	15	3	12	ns
	S3	Any DQB	3	15	3	12	
t_{pd}	\overline{W}	Any QA or DQB	5	23	5	19	ns
	DA	DQB	5	26	5	23	
	DQB	QA	5	26	5	23	

NOTE 1: Load circuit and voltage waveforms are shown in Section 1.