

NOTE: ALL MATERIAL COMPLIANT REACH STANDARD

REVISION INFORMATION

Rev.	Rev. Date	Modified By	Brief Description
A/0	19-04-24	T0424A	NEW DRAWING
A/1	19-05-14	B0514B	Remake Color
A/2	19-07-22	B0722A	Add twist per inch

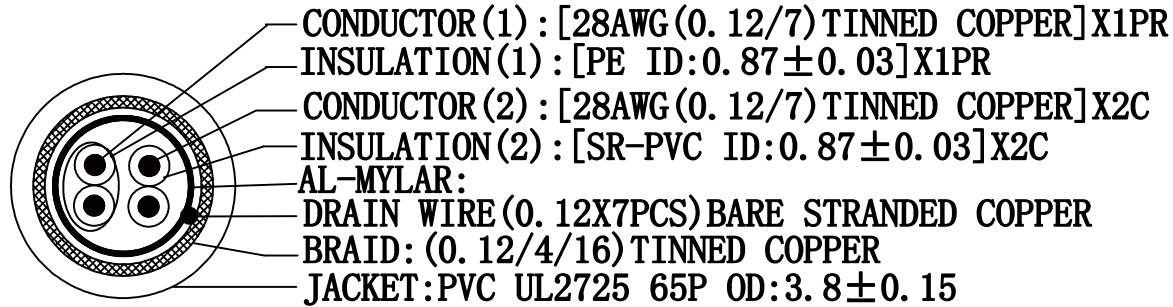
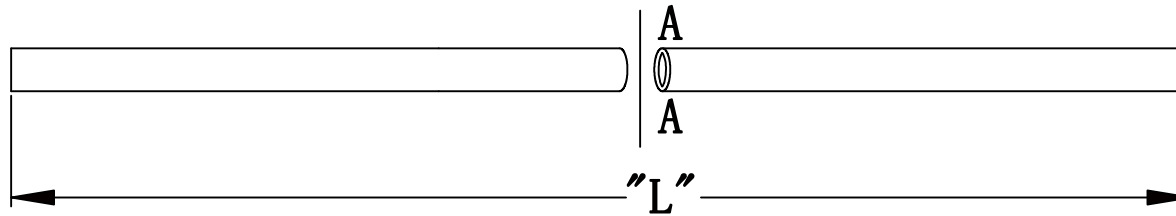

PLASTIC

PAPER

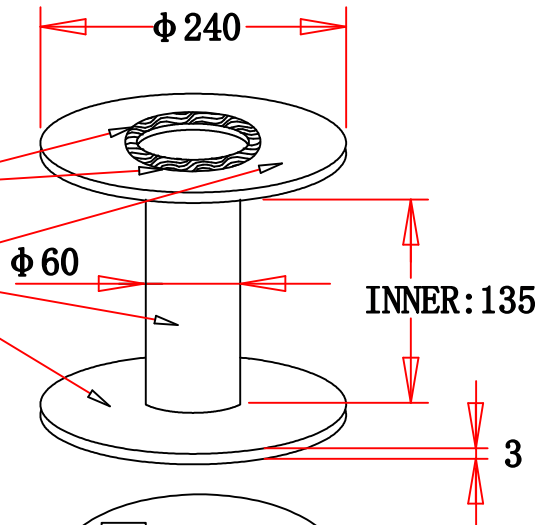

1. COLOR: (WHITE, GREEN) X1PR (1PR twist per inch is 15~18MM)
 (RED, BLACK) X2C (1PR+2C twist per inch is 70~80MM)

CABLE BLACK PRINT
 E166160 AWM 2725 80°C 30V
 28AWGX1P+28AWGX2C USB2.0

CnC Tech, LLC
 2725-2828-BE-01000-T
 1 PCS
 RoHS
 1821

P/N label

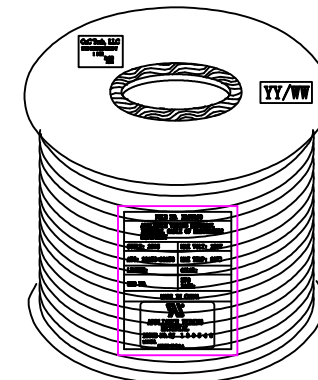
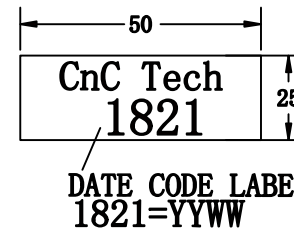

305M/R. "PE" FOAM WRAPPED

Parts number label: 50X25mm stick on the reel

PART NO	WIRE LENGTH L	CABLE COLOR	INTERNAL COLOR CODE
2725-2828-BE-01000-T	305M/R		IV-29#

CnC Tech, LLC

Industrial Cable and Connector Technology

DRAWN BY:	DATE: 2019/07/22	DESCRIPTION: 305M/R UL2725 4C CABLE
CHECKED BY:	SHEET 1 of 2	ITEM NO. 2725-2828-BE-01000-T
APPROVED BY:	SCALE 1:1	REV. A/2 UNIT: mm

NOTE: ALL MATERIAL COMPLIANT REACH STANDARD

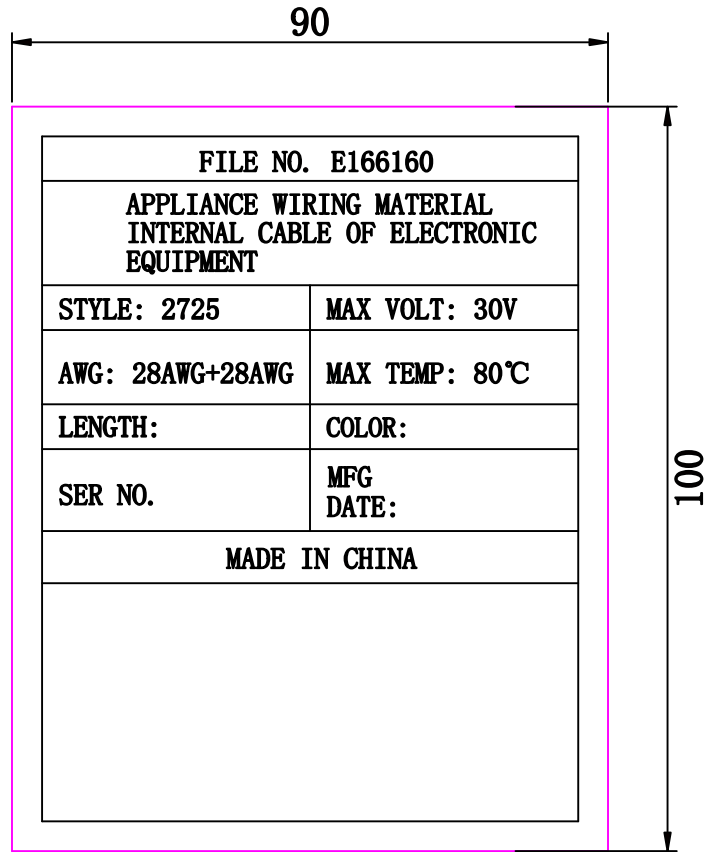

UL identification code

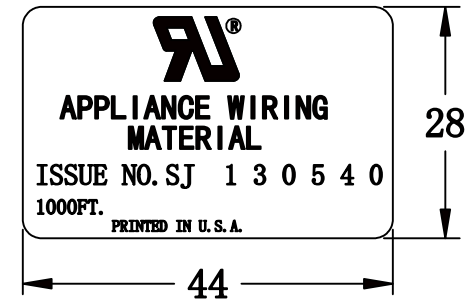

UL LABEL

<h2 style="margin: 0;">CnC Tech, LLC</h2> <p style="margin: 0;">Industrial Cable and Connector Technology</p>			
DRAWN BY:	DATE: 2019/07/22	DESCRIPTION: 305M/R UL2725 4C CABLE	
CHECKED BY:	SHEET 2 of 2	ITEM NO. 2725-2828-BE-01000-A	
APPROVED BY:	SCALE 1:1	REV. A/2	UNIT: mm