

# **BLE112 DEVELOPMENT KIT 2.0**

## DATASHEET

Monday, 24 February 2014

Version 1.2



## **Copyright © 2000-2014 Bluegiga Technologies**

All rights reserved.

Bluegiga Technologies assumes no responsibility for any errors which may appear in this manual. Furthermore, Bluegiga Technologies reserves the right to alter the hardware, software, and/or specifications detailed here at any time without notice and does not make any commitment to update the information contained here. Bluegiga's products are not authorized for use as critical components in life support devices or systems.

The WRAP is a registered trademark of Bluegiga Technologies

The *Bluetooth* trademark is owned by the Bluetooth SIG Inc., USA and is licensed to Bluegiga Technologies. All other trademarks listed herein are owned by their respective owners.

## VERSION HISTORY

Version	Comment
1.2	Figure 2 added
1.1	Chapter 2.9: Using the Analog Comparator of BLE112 added
1.0	Release

## TABLE OF CONTENTS

1	Design Overview .....	5
1.1	Sensors, display and USB to UART converter .....	6
2	Interfaces .....	7
2.1	Powering the Development Board .....	7
2.2	On-Board Debugger .....	7
2.2.1	Using the On-Board Debugger to Update the FW of the Embedded BLE112 Module .....	7
2.2.2	Using the On-Board Debugger to Update External Devices .....	7
2.3	Indicator LED .....	8
2.4	USB .....	8
2.5	UART .....	8
2.6	Display and Accelerometer .....	8
2.7	Pin Header and Buttons .....	9
2.8	Using the Analog Comparator of BLE112 .....	9
3	Measuring Current Consumption .....	10
4	Schematics And Assembly Drawing .....	11
5	WEEE Compliance .....	18
6	Contact Information .....	19

# 1 Design Overview

BLE112 Development Kit is targeted for engineers evaluating BLE112 *Bluetooth 4.0* single mode modules and developing or prototyping *Bluetooth 4.0* systems utilizing BLE112 module(s). BLE112 Development Kit features:

Evaluation board for BLE112 module containing

- On-Board debugger
- Switchable powering either from a coin cell battery or USB
- Switchable USB or UART interface through USB to UART converter
- programming interface for upgrading the firmware and parameters
- Display connected to SPI
- Accelerometer connected to SPI
- Potentiometer for ADC input
- Push buttons for 4 PIOs and reset
- All the PIOs available at a pin header
- Current measurement points for measuring peak currents of the module, DC current of the module and DC current of the whole board.

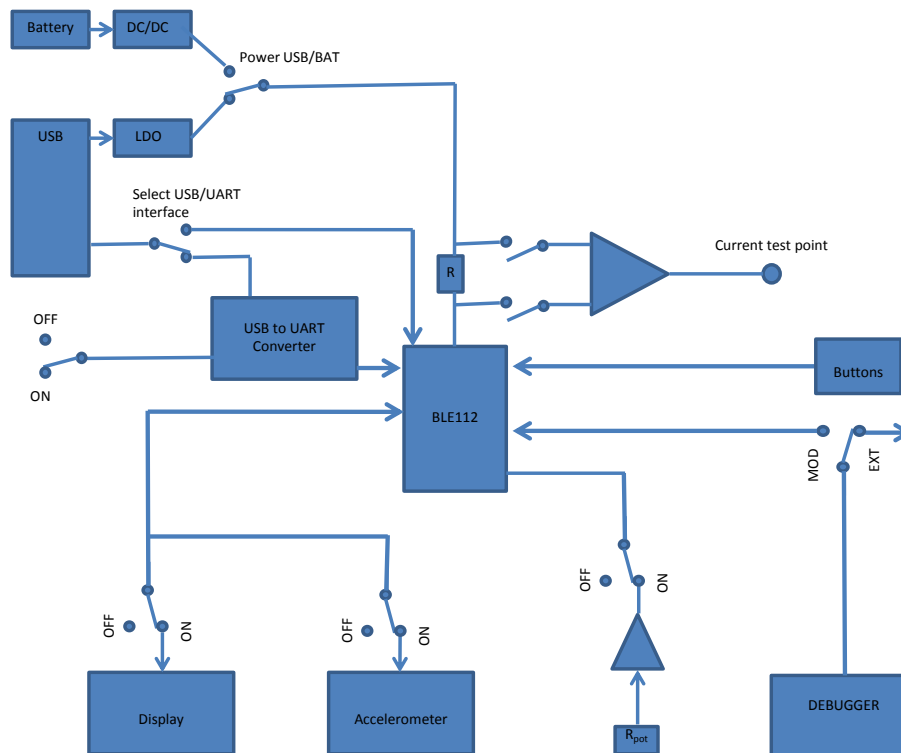

**Figure 1:** Block diagram of BLE112 evaluation board

Please, refer to the latest BLE112 data sheet for information about BLE112 *Bluetooth 4.0* single mode module. The physical outlook, schematics, assembly and the PIN configurations of the interfaces of BLE112 Development Kit are described in this document.

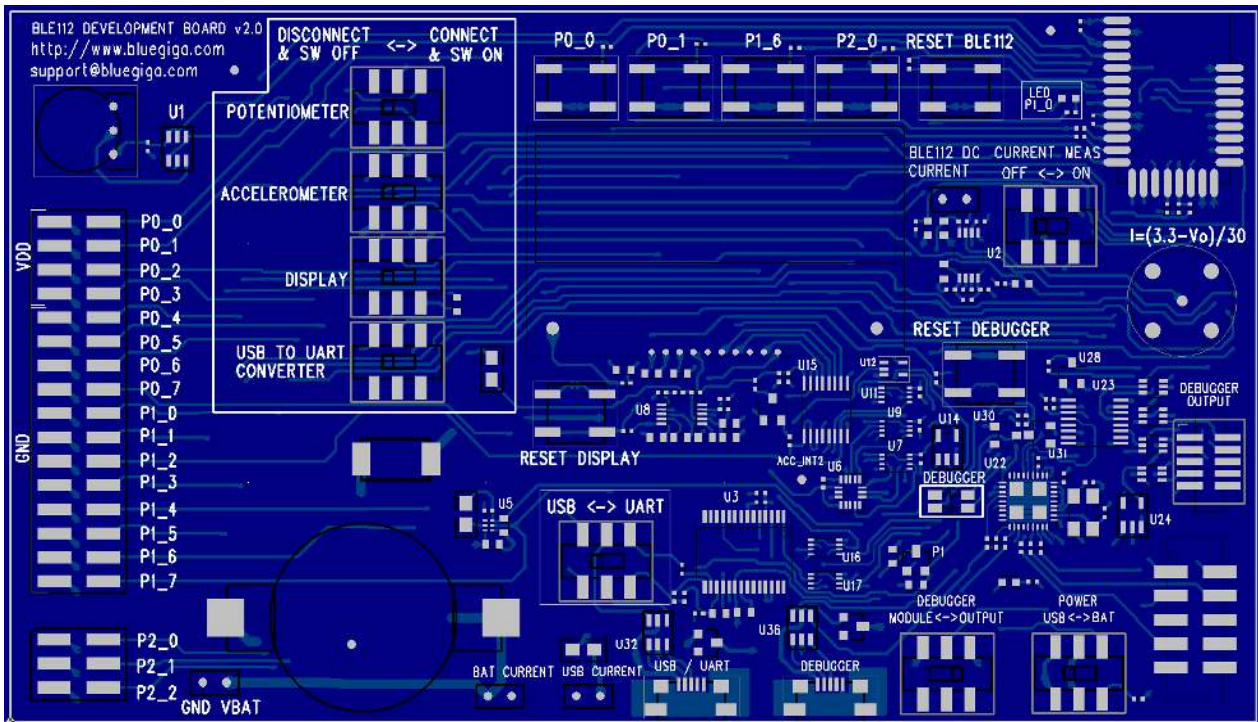

Figure 2: BLE112 Development Kit

## 1.1 Sensors, display and USB to UART converter

- USB to UART converter (U3)
  - Manufacturer: Prolific
  - Manufacturer part number: PL2303HX rev.D
  - Datasheet: [http://www.prolific.com.tw/US/ShowProduct.aspx?p\\_id=156&pcid=41](http://www.prolific.com.tw/US/ShowProduct.aspx?p_id=156&pcid=41)
- Display
  - Manufacturer: Newhaven Display Intl
  - Manufacturer part number: NHD-C0216CZ-FSW-FBW-3V3
  - Datasheet: <http://www.newhavendisplay.com/specs/NHD-C0216CZ-FSW-FBW-3V3.pdf>
- Altimeter (U6)
  - Manufacturer: Analog Devices
  - Manufacturer part number: ADXL350BCEZ-RL
  - Datasheet: <http://www.analog.com/en/mems-sensors/mems-inertial-sensors/adxl350/products/product.html>

## 2 Interfaces

### 2.1 Powering the Development Board

The board can be powered either from USB or from a coin cell battery. Absolute maximum battery voltage is 3.6V. USB or battery can be chosen with SW1. When using battery, the current measurement should also be switched off to avoid excessive leakage current to the instrumentation amplifier U2. To minimize the leakage currents the display, accelerometer and the potentiometer can be turned off and disconnected from the module by SW2, SW5 and SW6.

### 2.2 On-Board Debugger

The debugger can be used for SW updates and debugging of the embedded BLE112 module. Using SW14 the debugger output can be routed to the pin header J11 to debug external CC2540 or CC2541 based devices.

#### 2.2.1 Using the On-Board Debugger to Update the FW of the Embedded BLE112 Module

To update the FW for the embedded BLE112 module, connect USB cable from PC to the USB connector named "DEBUGGER". Set the switches as shown in the figure 3. When pressing "RESET DEBUGGER" button the debugger LED should turn green. Launch BLE Update Tool and follow the instruction in the Profile Toolkit Developer Guide available in <http://www.bluegiga.com/support>.

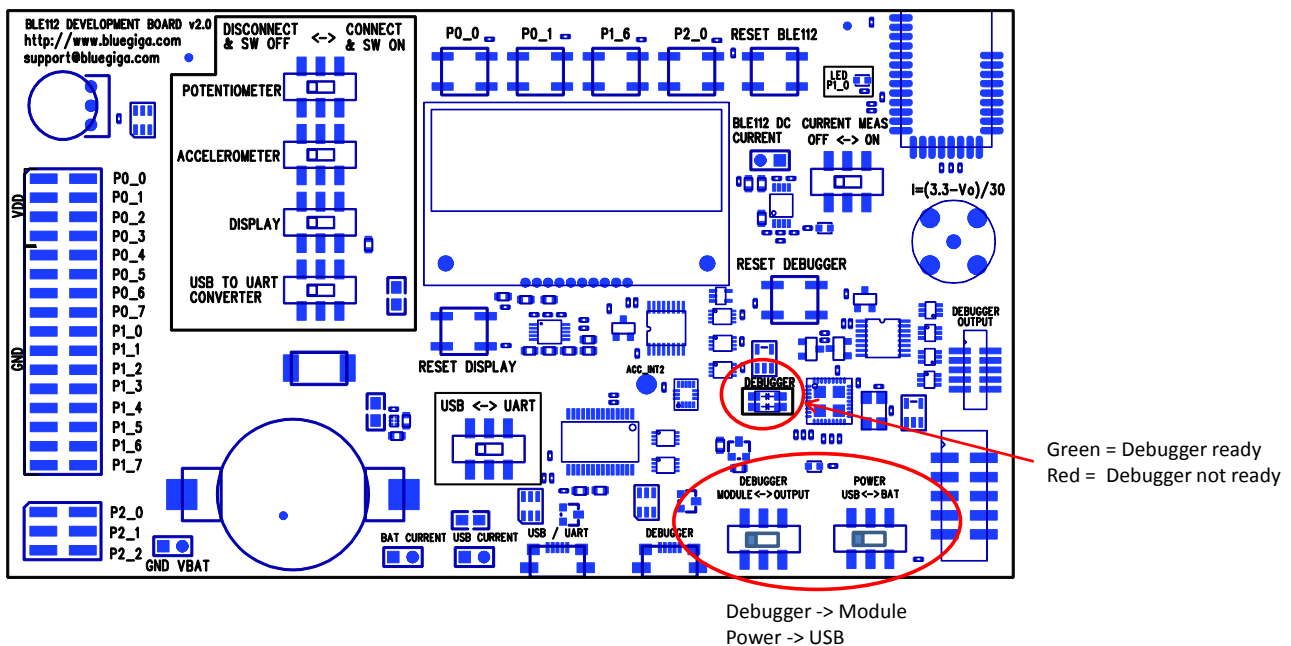

Figure 3: Using the debugger for the embedded BLE112

#### 2.2.2 Using the On-Board Debugger to Update External Devices

To update the FW for the embedded BLE112 module connect USB cable from PC to the USB connector named "DEBUGGER". Set the switches as shown in the figure 4. When pressing "RESET DEBUGGER" button the debugger LED should turn green.

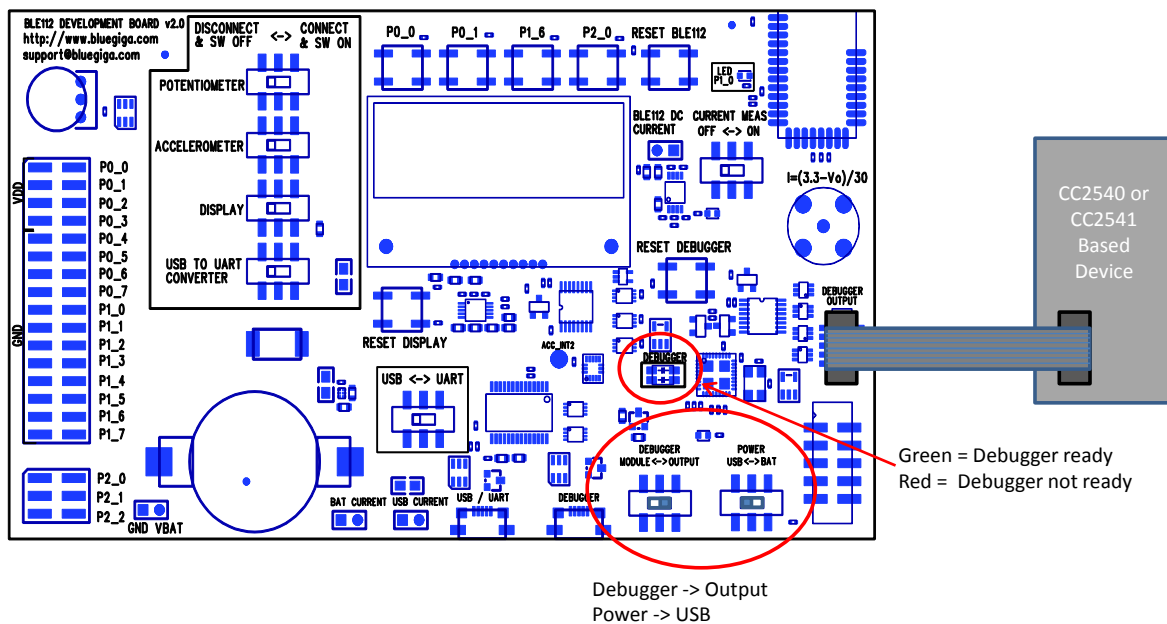

Figure 4: Using the debugger for external devices

## 2.3 Indicator LED

There is a LED connected to the pin P1\_0. The LED is powered directly from the battery so the brightness of it does not depend on if the DCDC is in use or not. However, if the module is not powered but the battery is in place, i.e. when USB not connected and the power switch is in USB position, there will be leakage through the LED and the LED is weakly lit. To prevent the LED draining the battery one should make sure either that the power switch is in BAT position and the module is in deep sleep, or that the battery is not connected when the power switch is in USB position.

## 2.4 USB

DKBLE112 operates as USB bus powered device. UART and USB interface share the same USB connector. To use the USB interface, turn SW13 to USB position.

## 2.5 UART

UART and USB interface share the same USB connector. To use the USB interface, turn SW13 to UART position. USB to UART converter creates a virtual COM port for accessing UART interface of the module. USB to UART converter is Prolific PL2303HX rev.D. Windows driver can be downloaded from Prolific web site:

([http://www.prolific.com.tw/US/ShowProduct.aspx?p\\_id=156&pcid=41](http://www.prolific.com.tw/US/ShowProduct.aspx?p_id=156&pcid=41)).

Note: Because the board is using the regulator of the Prolific chip, it will be recognized by the USB as a virtual COM port even if the power switch is in BAT position. Switching the power switch to BAT position, or disconnecting the USB converter using SW3, does not turn off the USB to UART converter.

## 2.6 Display and Accelerometer

The display shares the same SPI interface with the accelerometer. P1\_2 is used as the slave select for both. When P1\_2 is low the SPI is used to control the display. Charge pump is generating 3.3V supply for the display.



## 2.7 Pin Header and Buttons

All the PIOs are available and permanently connected in the pin header J2. In order to use certain PIOs through the pin header, that particular PIO must be disconnected from the device to which it is connected so that it is not actively driven by two devices. Following table shows the PIO connections in the evaluation board.

PIO Number	Connection In the Development Board
P0_0	Button 1
P0_1	Button 2
P0_2	UART CTS
P0_3	UART RTS
P0_4	UART TX
P0_5	UART RX
P0_6	Trimmer
P0_7	Accelerometer interrupt
P1_0	USB pull-up
P1_1	Display register select
P1_2	SPI slave select (high=accelerometer, low=display)
P1_3	SPI CLK
P1_4	SPI MISO
P1_5	SPI MOSI
P1_6	Button 3
P1_7	DCDC
P2_0	Button 4
P2_1	Debugger DD
P2_2	Debugger DC

**Table 1: PIO connections in the development board**

## 2.8 Using the Analog Comparator of BLE112

The analog comparator of BLE112 is fixed to the pins P0\_4 (-) and P0\_5 (+). The pins overlap with the UART TX and RX signals in DKBLE112. Thus to use the analog comparator the USB to UART converter must be turned off. Refer to Bluetooth Smart Software API Reference for details about the analog comparator configurations.

### 3 Measuring Current Consumption

The DC current consumption of the whole board can be measured from the headers J3 and J9. The DC current consumption of the module alone can be measured from the header J5. The peak current consumption of the module can only be measured when powering the module from USB. When powering from a battery, the current measurement amplifier should be disconnected with SW12. The peak current consumption of BLE112 is measured over 3 ohm resistor using an instrumentation amplifier with a gain of 10. The instrumentation amplifier is powered from USB 5V line and the DC bias is from the 3V3 LDO. Because the amplifier is powered from the USB VBUS, it can't be used unless USB is connected. If USB is not connected then the instrumentation amplifier must be disconnected by SW12 to avoid excessive leakage current into the input of the amplifier.

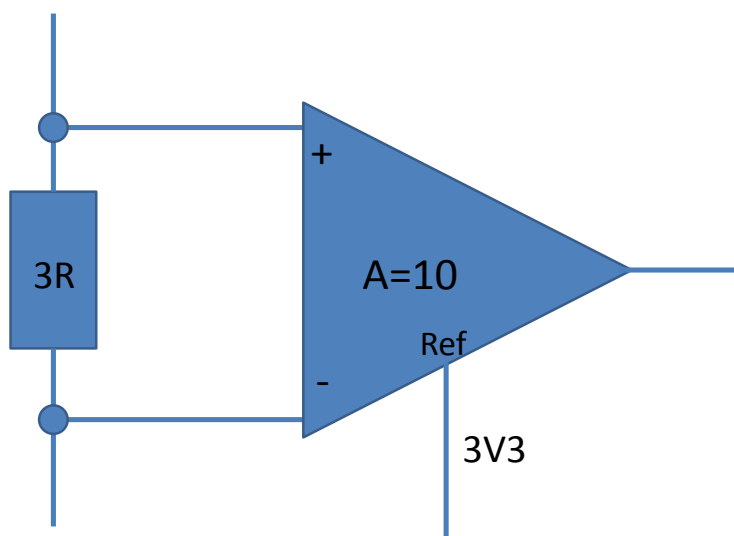

Figure 5: TX current measurement amplifier

To measure the peak TX current consumption of the module, connect a coaxial cable to the BNC connector in the board and to an oscilloscope. Set the oscilloscope

- Coupling: DC
- Vertical scale 500 mV/DIV
- Horizontal scale: 200  $\mu$ s/DIV
- Level: 2.5 V
- Offset: -2.0 V
- Trigger: Normal, falling edge

The instrumentation amplifier inverts the signal. The current consumption is calculated by

$$I = \frac{3.3V - V_o}{30\Omega}$$



## Push Buttons

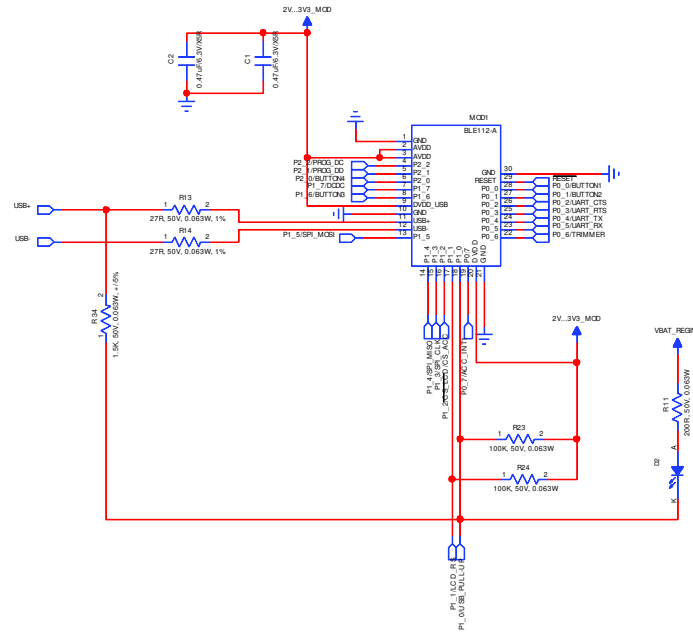
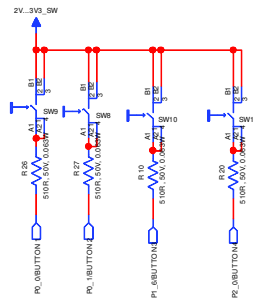

## Header

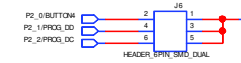
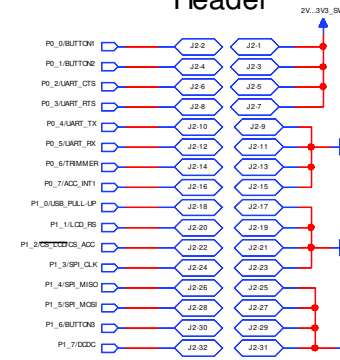

Figure 7: BLE112 Evaluation Board Schematic (2/6)

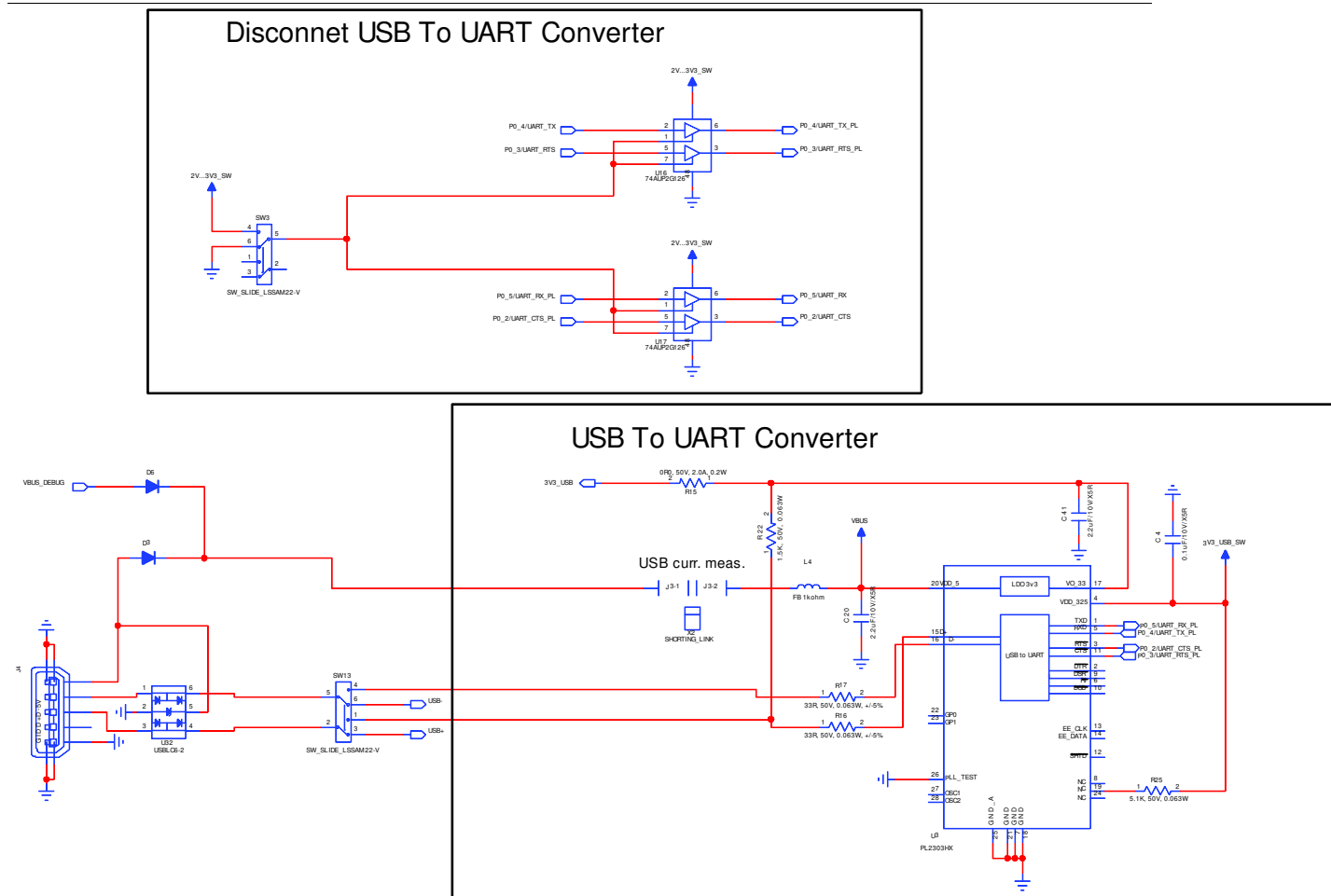

Figure 8: BLE112 Development Board Schematic (3/6)

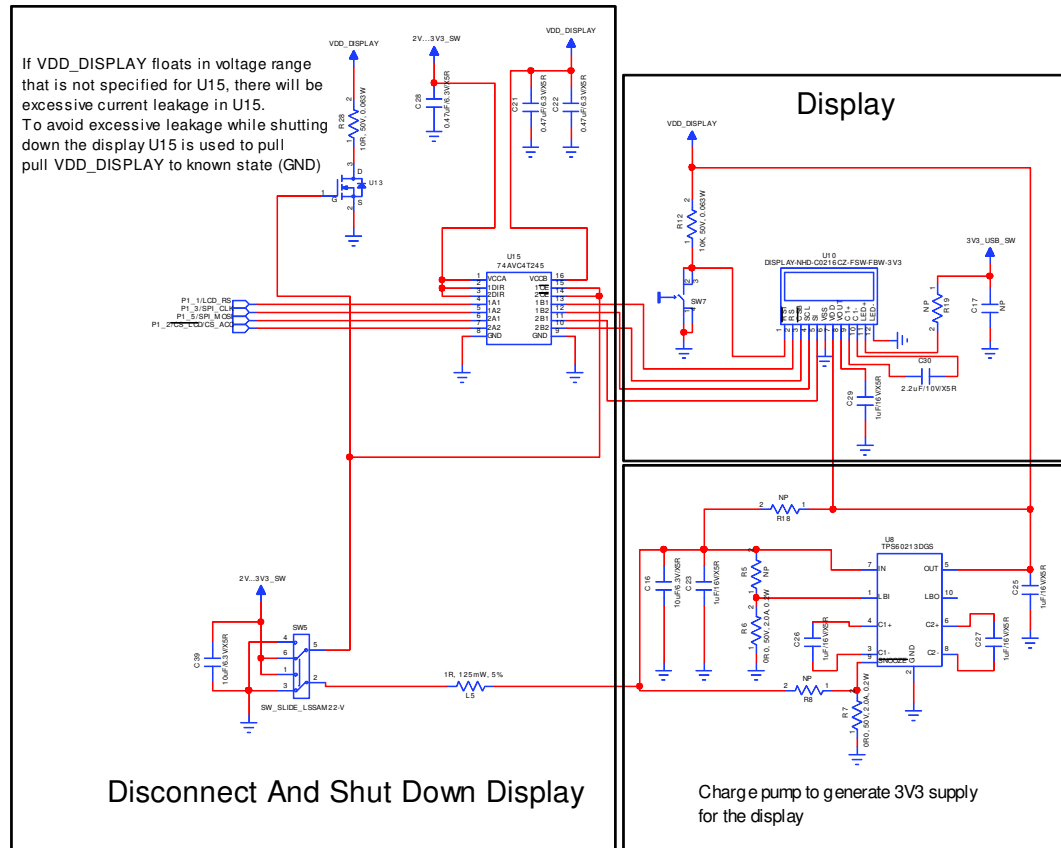

Figure 9: BLE112 Development Board Schematic (4/6)







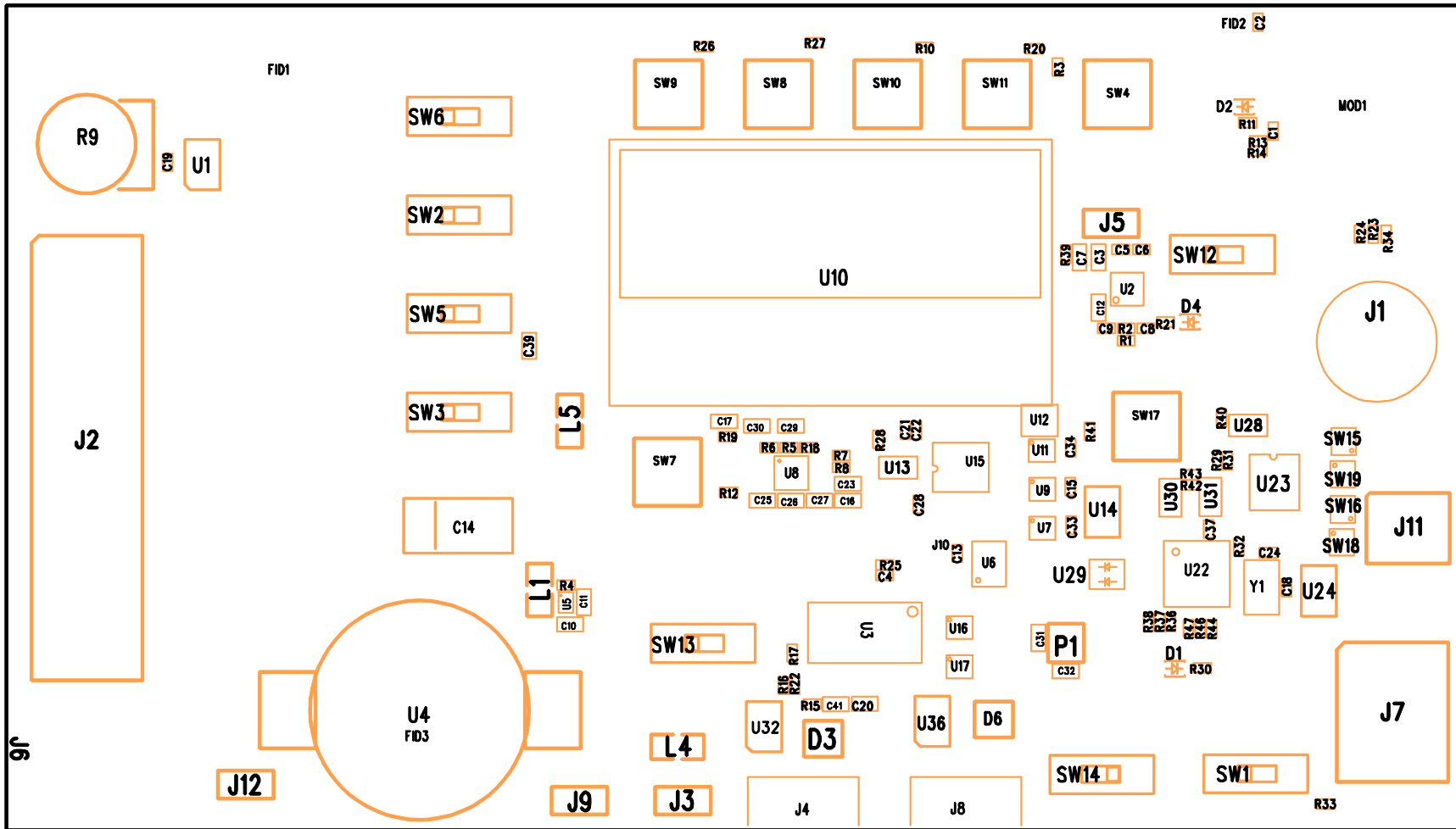

Figure 12: BLE112 Development Board Assembly Drawing

## 5 WEEE Compliance



The crossed-out wheeled bin means that within the European Union the product must be taken to separate collection at the product end-of-life. Do not dispose of these products as unsorted municipal waste.

## 6 Contact Information

**Sales:** [sales@bluegiga.com](mailto:sales@bluegiga.com)

**Technical support:** [support@bluegiga.com](mailto:support@bluegiga.com)  
<http://techforum.bluegiga.com>

**Orders:** [orders@bluegiga.com](mailto:orders@bluegiga.com)

**WWW:** [www.bluegiga.com](http://www.bluegiga.com)  
[www.bluegiga.hk](http://www.bluegiga.hk)

**Head Office / Finland:**

Phone: +358-9-4355 060  
Fax: +358-9-4355 0660  
Sinikalliontie 5A  
02630 ESPOO  
FINLAND

**Postal address / Finland:**

P.O. BOX 120  
02631 ESPOO  
FINLAND

**Sales Office / USA:**

Phone: +1 770 291 2181  
Fax: +1 770 291 2183  
Bluegiga Technologies, Inc.  
3235 Satellite Boulevard, Building 400, Suite 300  
Duluth, GA, 30096, USA

**Sales Office / Hong-Kong:**

Phone: +852 3972 2186  
Bluegiga Technologies Ltd.  
Unit 10-18  
32/F, Tower 1, Millennium City 1  
388 Kwun Tong Road  
Kwun Tong, Kowloon  
Hong Kong