

© 2019 TE Connectivity. All Rights Reserved.

REVISIONS					
P	LTR	DESCRIPTION	DATE	DWN	APVD
A2		ECR-09-013545	12MAY2009	SR	AR
A3		REVISED PER ECR-17-013084	08JAN2018	NC	MKO
A4		REVISED PER ECR-19-007853	17MAY2019	SR	JB

NOTES

- 1 PART SHALL BE FREE AND CLEAN OF BURRS AND OTHER FOREIGN MATERIAL
- 2 PACKAGING: QUANTITY 3 PIECES
- 3 VARNISHING INSIDE HOUSING NOT REQUIRED
- 4 OBSOLETE PARTS

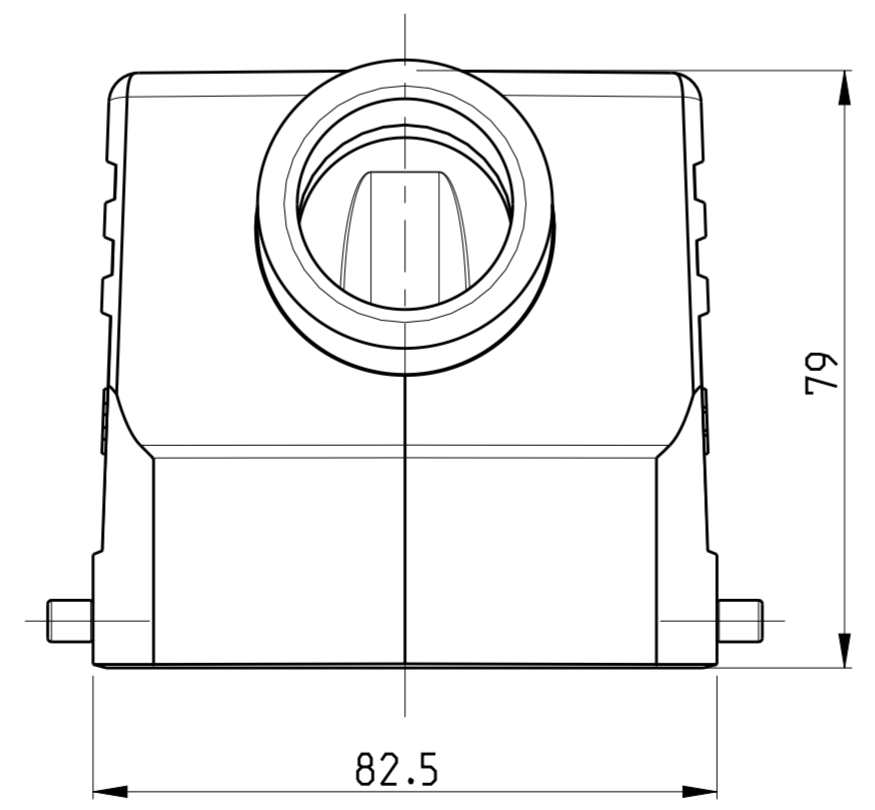
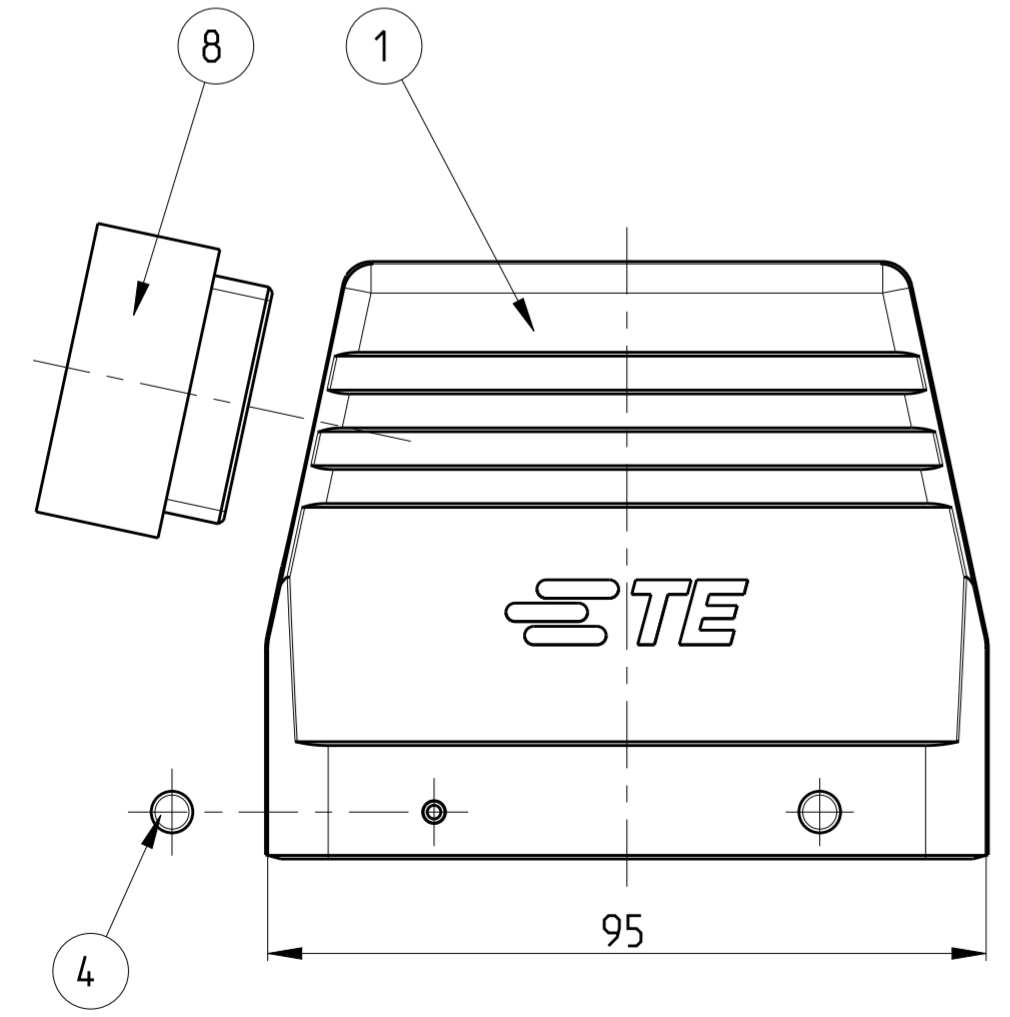
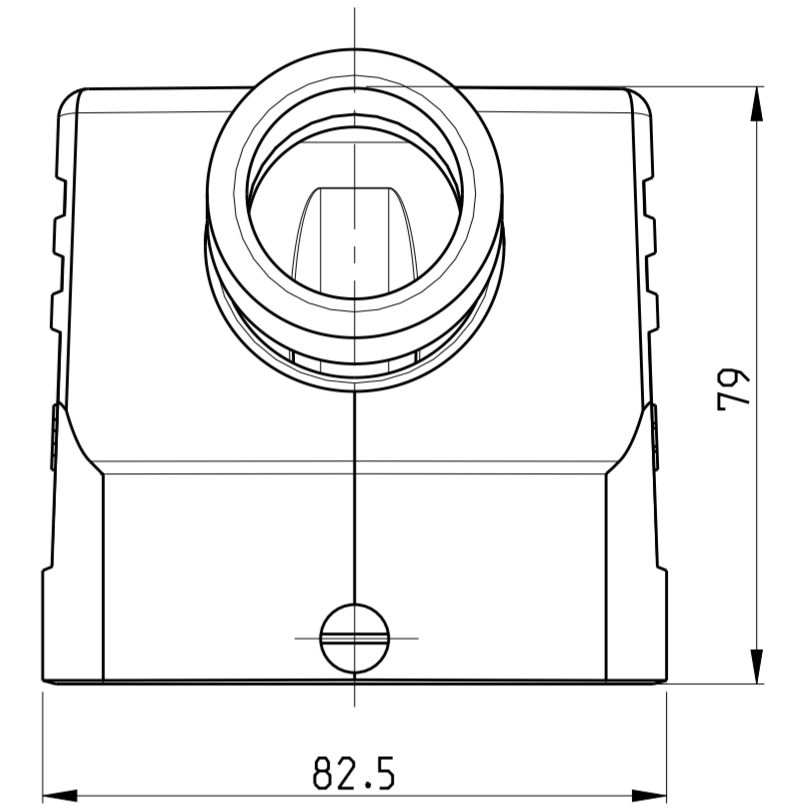
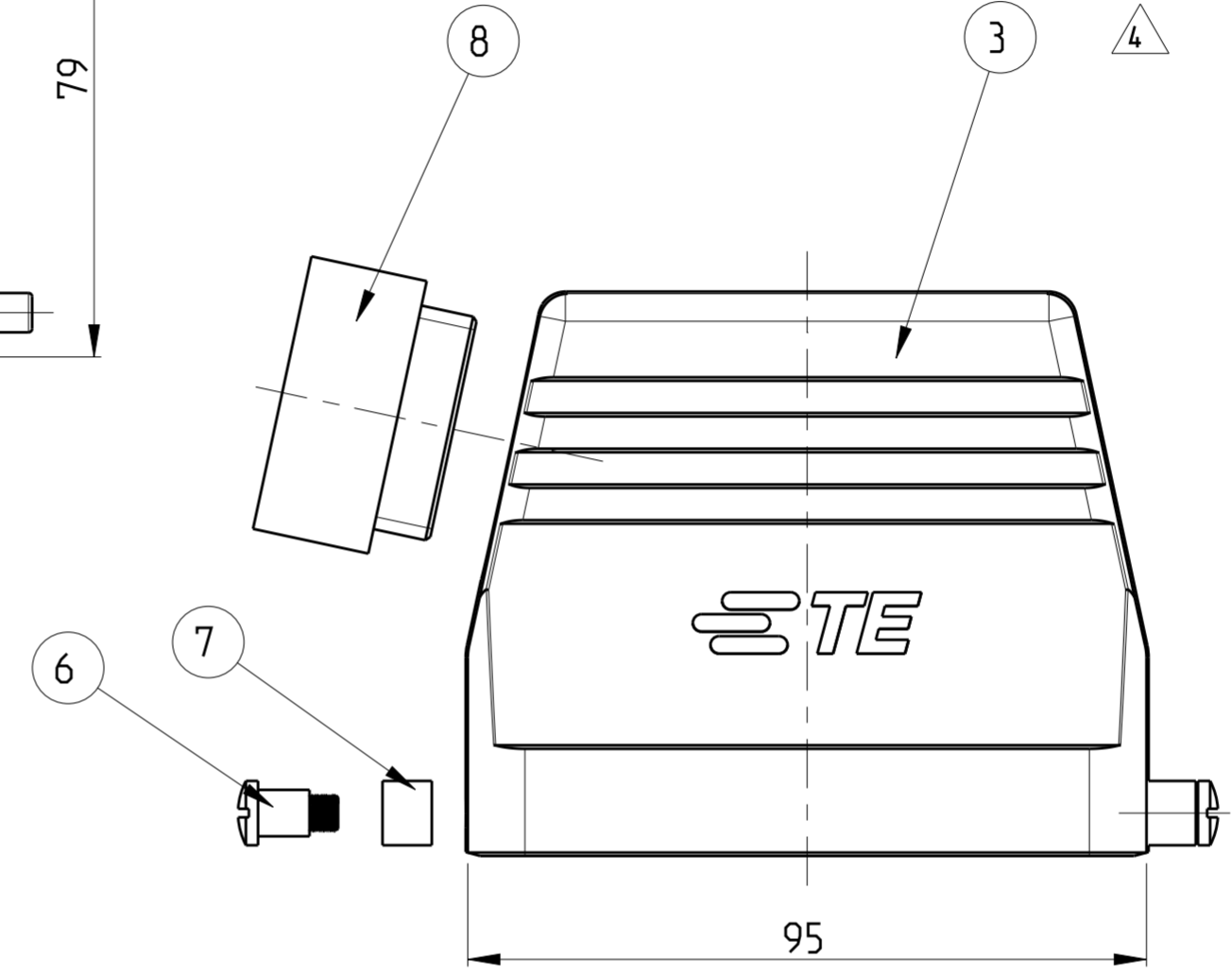
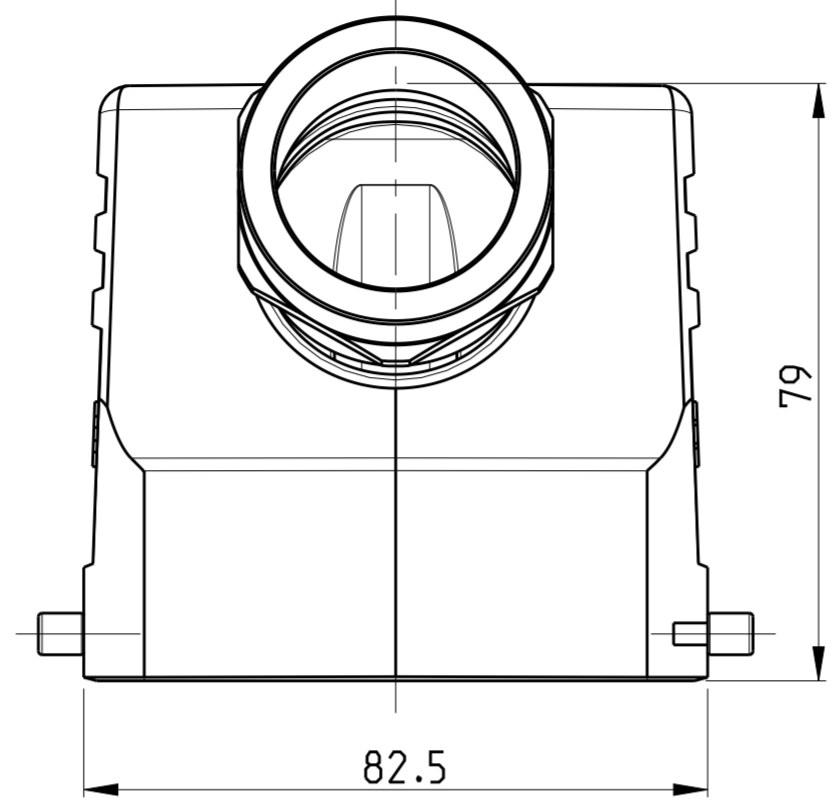
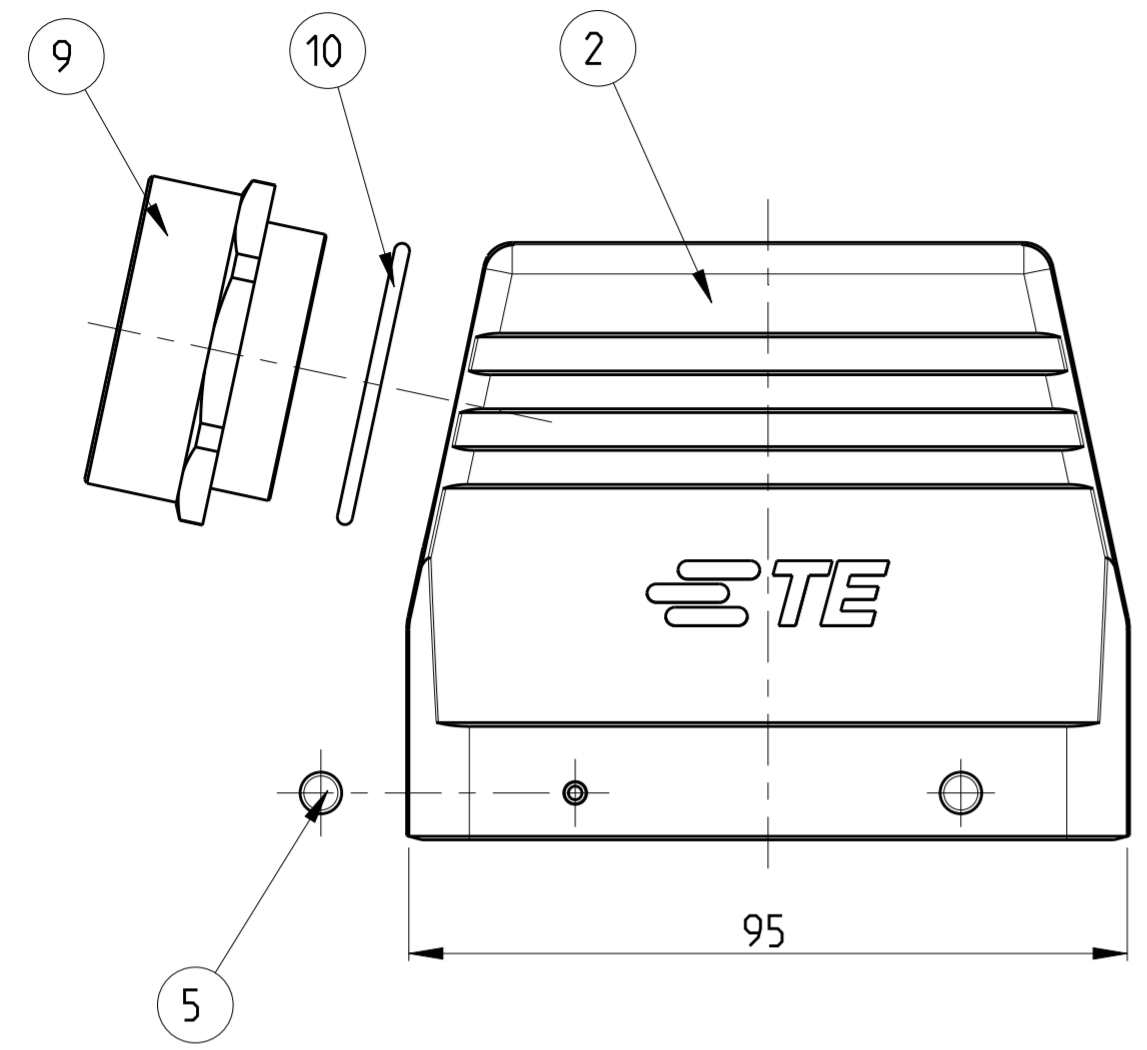

QTY	CALLOUT	DESCRIPTION	MATERIAL	SURFACE	COLORE	ITEM	NOTES
1	1	O-RING	NEOPRENE		BLACK	10	PG29
1	1	ADAPTOR	BRASS	NICKEL PLATED	BLUE	9	PG29
1	1	ADAPTOR ROUND	BRASS	NICKEL PLATED	BLUE	8	PG29
2	2	SLIDE SPOOL	STEEL	ZINC PLATED	BLUE	7	
2	2	CLIP BOLT	STEEL	ZINC PLATED	BLUE	6	
4	4	CLIP BOLT	STAINLESS STEEL	BLANC		5	
1	1	CLIP BOLT	STEEL	ZINC PLATED	BLUE	4	
1	1	HOOD	ALUMINIUM		GREY	3	
1	1	HOOD	ALUMINIUM	ALUMINIUM OXID	BLACK	2	
1	1	HOOD	ALUMINIUM		GREY	1	

HB.32.STS.1.29.Z  
 HB-K.32.STS.1.29.Z  
 HB.32.STS-GR.1.29.Z

THIS DRAWING IS A CONTROLLED DOCUMENT.

DWN R.SCHNEIDER CHK T.SCHNURPFEL	12MAY2009 12MAY2009	 TE Connectivity	NAME HOOD HB.32.STS.1.29.Z
APVD -	-		RESTRICTED TO
DIMENSIONS: mm	TOLERANCES UNLESS OTHERWISE SPECIFIED: 0 PLC ± 1 PLC ± 2 PLC ± 3 PLC ± 4 PLC ± ANGLES ±° FINISH	PRODUCT SPEC - APPLICATION SPEC -	SIZE A2
MATERIAL -	-	WEIGHT -	CAGE CODE 00779
CUSTOMER DRAWING		SCALE 1:1	DRAWING NO C-1102347
		SHEET 1 OF 1	REV A4