

MAXIM

MAX2510 Evaluation Kit

Evaluates: MAX2510

General Description

The MAX2510 evaluation kit (EV kit) simplifies testing of the MAX2510 low-power IF transceiver with limiter/received-signal-strength indicator (RSSI) and quadrature modulator. This EV kit allows simple evaluation of all chip functions in a 50Ω test environment.

Component Suppliers

SUPPLIER	PHONE/ FAX	INTERNET
Coilcraft	(847) 639-6400/ (847) 639-1469	http://www.coilcraft.com
Murata-Erie	(814) 237-1431/ (814) 238-0490	http://www.murata.com
Sprague	(603) 224-1961/ (603) 224-1430	—

Features

- ◆ +2.7V to +5.5V Single-Supply Operation
- ◆ Allows Testing of Advanced Power Management (four modes):
 - < 1nA Shutdown
 - Receive
 - Transport
 - Standby
- ◆ 50Ω SMA Connector Interface
- ◆ Fully Assembled and Tested

Ordering Information

PART	TEMP. RANGE	IC PACKAGE
MAX2510EVKIT-SO	-40°C to +85°C	28 QSOP

Component List

DESIGNATION	QTY	DESCRIPTION
C1, C3	2	0.01μF capacitors
C2	1	330pF ceramic capacitor
C4	1	0.047μF capacitor
C6, C8	2	47pF capacitors (0603)
C5, C10, C30, C31	0	Not installed
C7, C9, C12, C13, C21, C22, C23, C27	8	0.1μF capacitors
C14, C15, C17, C19	4	0.001μF capacitors
C18, C25	2	10pF capacitors (0603)
C20, C29	2	0.022μF capacitors
C24	1	10μF tantalum capacitor Sprague 293D106X0010C2
L2	1	82nH inductor Coilcraft 0805HS-820TKBC
L3, L4	2	47nH inductors Coilcraft 0805HS-470TKBC
LO IN, I, Q, RXIN, RXIN, TXOUT, TXOUT, MIXOUT, LIMIN	9	50Ω edge-mount SMA connectors E.F. Johnson 142-0701-801

DESIGNATION	QTY	DESCRIPTION
R3, R11, R17	3	50Ω resistors
R4, R7, R8, R14	4	5kΩ resistors
R1, R5	2	0Ω shorts (0603) (can be changed to allow for other matching networks)
R9	1	Resistor—not installed (for back-terminating an interstage filter)
R10, R15	2	280Ω 1% resistors
R16	1	Resistor—not installed (for adjusting the RSSI output voltage range)
U1	1	MAX2510EEI (28 QSOP)
U2	1	10.7MHz ceramic bandpass filter (Z _O = 330Ω), 3-pin through-hole footprint Murata SFE10.7MA5-A
RXEN, TXEN	2	3-pin headers (0.1" center)
	2	Shunts
None	1	MAX2510EV-SO circuit board
None	1	MAX2510EEI data sheet

Note: All resistors, capacitors, and inductors are surface-mount components with an 0805 footprint, unless otherwise specified. Filter U2 and the various jumpers are through-hole mounted.

MAX2510 Evaluation Kit

Quick Start

The following section provides instructions for operating the EV kit as an IF transceiver. The RF ports (RXIN, RXIN, TXOUT, and TXOUT) are matched to 50Ω at 240MHz, and the second IF is configured for 10.7MHz operation. The EV kit and the MAX2510 can be configured for operation at other frequencies (see the *Detailed Description* section and the MAX2510 data sheet).

Test Equipment Required

This section lists the test equipment recommended for verifying operation of the MAX2510. It is intended only as a guide; some substitutions may be possible.

- Two RF-signal generators capable of delivering at least 0dBm of output power up to 500MHz (HP8656B, HP8648A, or equivalent). One generator is required for the local oscillator (LO) source in both transmit (Tx) and receive (Rx) modes. The other is required for the Rx input signal in Rx mode.
- An RF spectrum analyzer that can cover the transmitter's output frequency range, as well as a few harmonics (HP8560E, for example).
- A baseband-signal generator that can produce two outputs in quadrature (sine and cosine waves) at levels of approximately 500mVp-p. This is necessary to evaluate the transmitter's sideband suppression. The HP8904A/Opt. 002 generator provides sine and cosine outputs at frequencies up to 600kHz.
- **Optional:** An RF 180° hybrid combiner or balun (Anzac H-9 or equivalent). This is used for differential coupling into the RXIN, RXIN connections on the receiver or the TXOUT, TXOUT connections on the transmitter. If a balun is not available, these inputs and outputs can be evaluated in a single-ended configuration, at a slight performance cost.
- A voltmeter for measuring the RSSI output voltage.
- An oscilloscope for observing the limiter output signals.
- A power supply that can provide up to 50mA at +2.7V to +5.5V.
- Two 0V to 5V adjustable voltage sources for providing gain-control (GC) pin voltage and the VBIAS voltage for the I and Q inputs.
- Two 50Ω SMA terminators
- Several 50Ω SMA cables

Connections and Setup

This section provides step-by-step instructions for getting the EV kit up and running in both Tx and Rx modes.

Tx Mode

Perform the following steps to set up the EV kit in Tx mode:

- 1) Make the DC connections: set the power supply to 3V, and connect it to the VCC and GND terminals on the EV kit. Set one of the voltage sources to 1.4V, and connect it to VBIAS. Set the other voltage source to 2V, and connect it to the gain-control terminal (marked GC).
- 2) Set the part in Tx mode by putting 3-pin jumper TXEN in the "high" position, and jumper RXEN in the "low" position.
- 3) The supply current should be near 30mA. If this is not the case, check the voltage on the TXEN and RXEN test points. The TXEN voltage should be at VCC, and the RXEN voltage should be at ground.
- 4) Connect TXOUT to the spectrum analyzer using an SMA cable. Terminate TXOUT with a 50Ω SMA terminator.

For differential operation, TXOUT and TXOUT can be combined using a balun. Connect the balun's output to the spectrum analyzer. Set the spectrum analyzer to 240MHz center frequency with a 1MHz total span.

- 5) Connect the local oscillator (LO) signal source to the LO SMA connector. Set the frequency to 240MHz and the amplitude to -13dBm. You will see a small amount of LO signal present at the center of the spectrum-analyzer display.
- 6) Set both channels of the baseband-signal generator to deliver sine waves at 500mVp-p at a frequency of 100kHz. To achieve maximum sideband suppression, be sure that there is a precise 90° phase difference between these two sinusoidal signals. Connect the first signal to the I input. You will see a double sideband signal (DSB) on the spectrum analyzer at 240MHz, with the lower sideband at (240MHz - 100kHz) and the upper sideband at (240MHz + 100kHz). Connect the other signal to the Q input. If the phase difference is set correctly, you will see a cancellation of the sidebands. Which sideband is canceled depends on which input leads the other in phase. Swapping the I and Q connections at the board's input suppresses one or the other sideband. Leave the part set to transmit the upper sideband (USB) when finished. The rest of these instructions assume the

MAX2510 Evaluation Kit

transmitter is set in USB mode and the lower sideband (LSB) is the suppressed sideband. If the application requires LSB, reverse the relevant instructions. The EV kit also accommodates differential I and Q inputs. (Refer to the *Detailed Description* section.)

- 7) The USB output power should be approximately 0dBm with GC = 2V. Test the GC function by slowly lowering the voltage on the GC pin from 2V to 0V. You will see at least a 40dB change in USB power over this voltage range.
- 8) When the transmitter is working properly, you may wish to test other features, such as shutdown mode (both TXEN and RXEN jumpers set to "low". The I and Q inputs can be adjusted to check transmitter gain over frequency, VBIAS voltage, etc.

Rx Mode

This section describes how to connect and use the MAX2510's receiver section.

- 1) Remove the I and Q input signal sources to prevent crosstalk into the receiver during Rx-mode measurements. The GC and VBIAS voltage supplies have no function in Rx mode.
- 2) Switch the part into Rx mode by moving the RXEN jumper to the "high" position and the TXEN jumper to the "low" position.
- 3) Change the LO frequency to equal the desired Rx frequency minus 10.7MHz. This provides a 10.7MHz downconverted signal into the off-chip filter (a 10.7MHz bandpass type). For a 240MHz Rx frequency, the LO frequency should be $(240 - 10.7 = 229.3 \text{ MHz})$. Leave the LO power level at -13dBm.
- 4) Connect RXIN to a second RF-signal generator using an SMA cable. Terminate $\overline{\text{RXIN}}$ with 50Ω .
For differential operation, connect the signal generator to RXIN and $\overline{\text{RXIN}}$ through a balun. Set this generator's frequency to 240MHz at -30dBm of output power.
- 5) Connect an oscilloscope to the limiter outputs LIMOUT and $\overline{\text{LIMOUT}}$. A 2-channel oscilloscope with low-capacitance probes is ideal. The signals from LIMOUT and $\overline{\text{LIMOUT}}$ should be approximately 600mVp-p and out-of-phase with each other.
- 6) Connect a voltmeter to the RSSI test pad in the upper-left corner of the EV kit to monitor the RSSI output voltage. For -30dBm of RXIN power, the RSSI voltage should be 1.8V. Lower the input power in 10dBm steps, observing the decrease in RSSI output voltage of about 20mV per 1dB change in input power. Return the power level to -30dBm.

- 7) Observe that the signals at LIMOUT and $\overline{\text{LIMOUT}}$ remain at constant level over the RXIN power range.

Advanced System Power-Management Features

Besides the Tx and Rx modes previously mentioned, the MAX2510 supports two other operating modes: shutdown and standby. Bring both TXEN and RXEN jumpers to the "low" position, putting the part in shutdown mode and reducing the supply current to 2.0 μ A (typical).

To enter standby mode, bring both TXEN and RXEN jumpers to the "high" position. This reduces the supply current to about 0.5 μ A while leaving the VREF generator active (for fast switching into receive mode).

Detailed Description

The following section covers the EV kit's circuit design in detail. (See the MAX2510 data sheet for additional information.)

Baseband Inputs

The I, $\overline{\text{I}}$, Q, and $\overline{\text{Q}}$ pins comprise the quadrature modulator's baseband inputs. They require external DC biasing to set a common-mode level of approximately 1.4V. On the EV kit, this voltage is provided by external resistors and a voltage supply (VBIAS). The I and Q pins are AC coupled to SMA connectors, which induces a high-pass cutoff of approximately 300Hz. The $\overline{\text{I}}$ and $\overline{\text{Q}}$ pins are biased to the common-mode voltage and AC grounded. Test points on the EV kit allow flexible access to these pins if the application requires differential drive.

Transmitter Output

The MAX2510's Tx outputs (TXOUT and $\overline{\text{TXOUT}}$) are high-impedance open collectors; therefore, external inductors are used for proper biasing. DC-blocking capacitors are used to connect to these outputs. The inductors and capacitors act only to provide biasing; they do not set the output impedance. For single-ended applications, terminate $\overline{\text{TXOUT}}$ with a 50Ω terminator. Alternatively, replace L4 with a 0Ω short. Refer to the MAX2510 data sheet for more information on matching this port.

Receiver Input

The Rx inputs (RXIN and $\overline{\text{RXIN}}$) require an impedance-matching network for optimum performance. The Rx inputs are matched to 240MHz on the EV kit as shipped. The input matching network comprises a series capacitor from each Rx input SMA connector to the part, as well as a shunt inductor across RXIN and $\overline{\text{RXIN}}$. The EV kit layout provides space for additional components: one series element on each side and a

MAX2510 Evaluation Kit

shunt element across the inputs. The additional series elements have been replaced by 0Ω shorts, and the additional shunt element is not installed. Refer to the MAX2510 data sheet for more information on designing a matching network for this port.

Receiver Output

The receive downconverter mixer's output appears at the MIXOUT pin (a current source that can drive a 165Ω load to 2Vp-p). The MIXOUT pin is terminated with a net 330Ω ($R10 + R11$) for proper match to the bandpass filter ($Z_0 = 330\Omega$). Therefore, the net load at MIXOUT is $330\Omega \parallel 330\Omega = 165\Omega$.

The EV kit design allows separate testing of the MAX2510's Rx mixer and limiter sections for testing the Rx mixer only. Coupling capacitor C20 is used to connect the node between R10 and R11 to an external SMA connector (MIXOUT). For these tests, the filter (U2) must be removed, and R10 replaced with a 140Ω resistor. This network has some attenuation, but presents the correct impedance to the MIXOUT pin and provides a nearly 50Ω output impedance for measurement. The attenuation is 11.2dB.

Limiter Input

The MAX2510 EV kit can be modified to allow separate testing of the limiter only, similar to the receive mixer in the previous section. The filter (U2) must be removed. This allows the limiter SMA connector to be used as a direct input to the limiter.

Limiter Output

The downconverted, limited signal appears at the LIMOUT and $\overline{\text{LIMOUT}}$ pins as a 1.2Vp-p differential voltage (600mVp-p per side). For single-ended use, the unused side can be left open. The limiter outputs can deliver this voltage across a load as low as 250Ω .

Layout Issues

A good PC board is an essential part of an RF circuit design. The EV kit PC board can serve as a guide for laying out a board using the MAX2510.

Rx Inputs and Tx Outputs

The layout of the RXIN and $\overline{\text{RXIN}}$ input matching network should be laid out symmetrically to provide the best input balance if used as a differential input. The TXOUT and $\overline{\text{TXOUT}}$ biasing networks should also be laid out symmetrically to present an equal load impedance on each pin.

Baseband Inputs

The MAX2510's I, $\overline{\text{I}}$, Q, and $\overline{\text{Q}}$ inputs are high impedance; take care to minimize potential unwanted coupling into these pins. The easiest way to accomplish this is to keep the trace length to a minimum.

Power-Supply Decoupling

Each V_{CC} node on a PC board should have its own $0.047\mu\text{F}$ decoupling capacitor. This minimizes supply coupling from one section of the MAX2510 to another. A star topology for the supply layout, in which each V_{CC} node on the MAX2510 circuit has a separate connection to a central V_{CC} node, can further minimize coupling between sections of the MAX2510.

MAX2510 Evaluation Kit

Evaluates: **MAX2510**

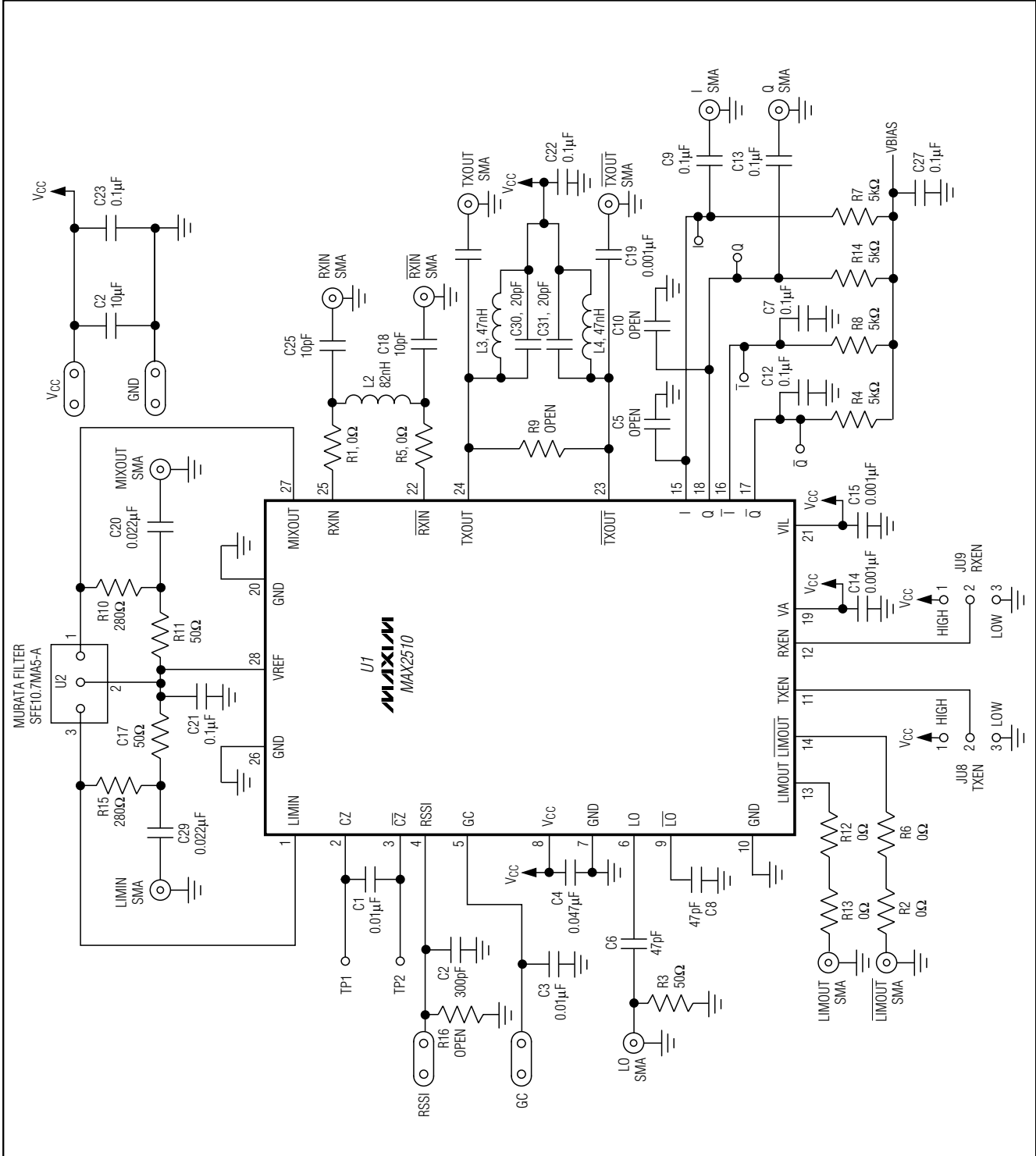

Figure 1. MAX2510 EV Kit Schematic

MAX2510 Evaluation Kit

Evaluates: MAX2510

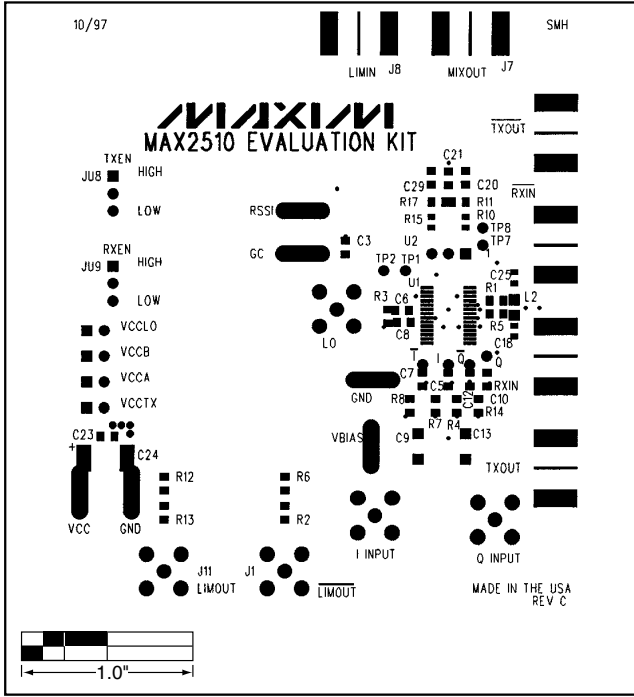

Figure 2. MAX2510 EV Kit PC Board Layout—Top Silkscreen and Pad Placement

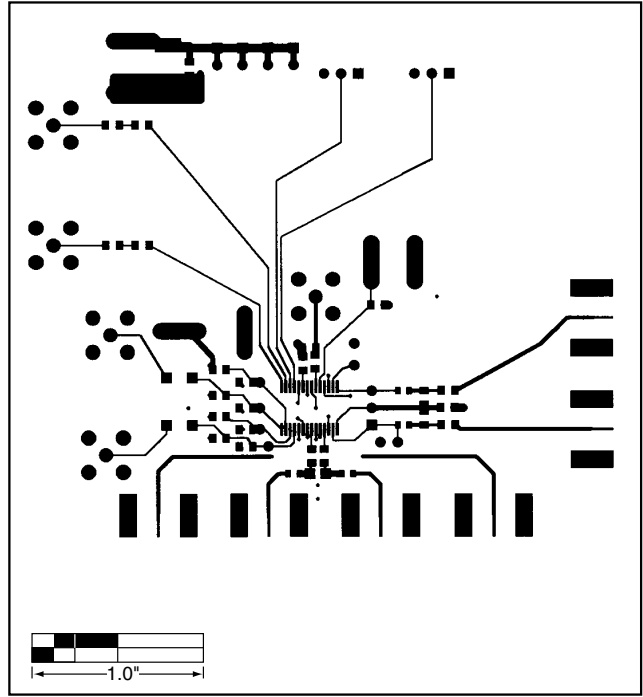

Figure 3. MAX2510 EV Kit PC Board Layout—Component Side (layer 1)

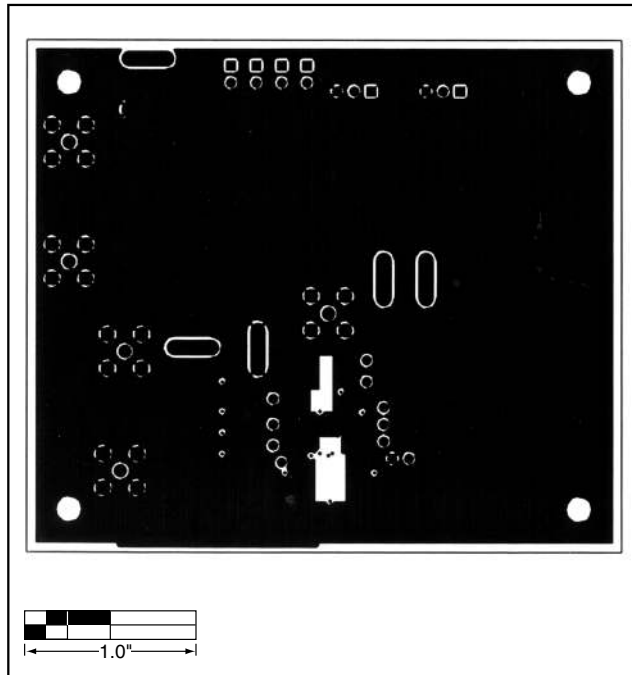

Figure 4. MAX2510 EV Kit PC Board Layout—Ground Plane (layer 2)

MAX2510 Evaluation Kit

Evaluates: MAX2510

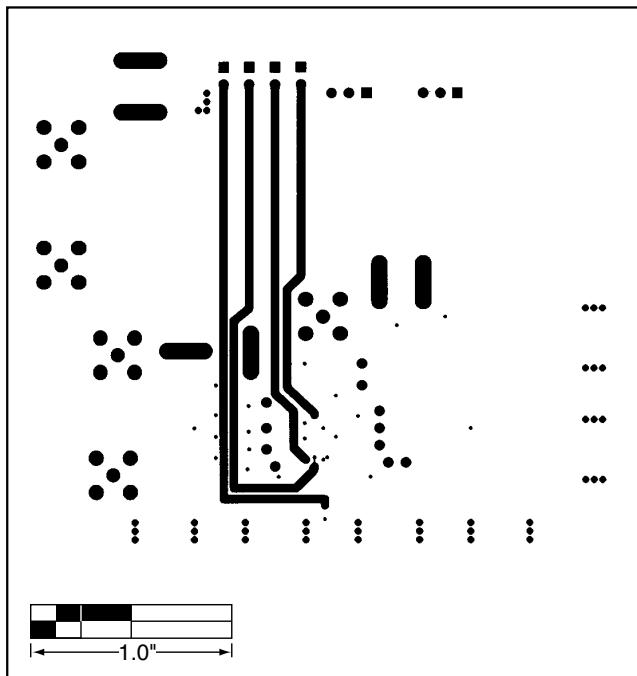

Figure 5. MAX2510 EV Kit PC Board Layout—Power-Supply Routing (layer 3)

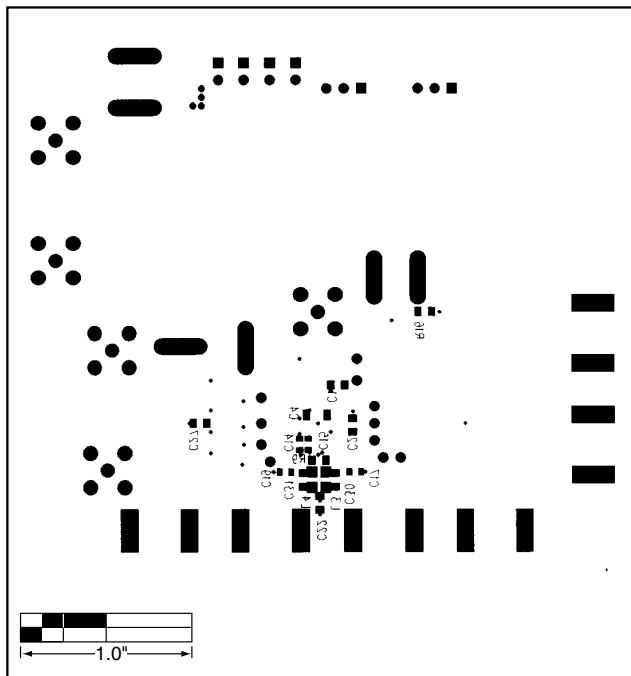

Figure 6. MAX2510 EV Kit PC Board Layout—Bottom Silkscreen and Pad Placement

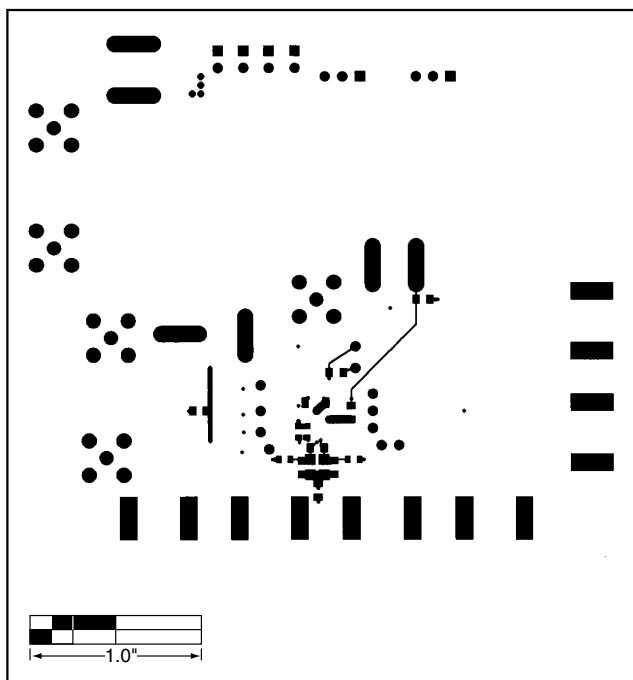

Figure 7. MAX2510 EV Kit PC Board Layout—Bottom (solder side) (layer 4)

MAX2510 Evaluation Kit

Evaluates: MAX2510

NOTES

Maxim cannot assume responsibility for use of any circuitry other than circuitry entirely embodied in a Maxim product. No circuit patent licenses are implied. Maxim reserves the right to change the circuitry and specifications without notice at any time.

8 _____ **Maxim Integrated Products, 120 San Gabriel Drive, Sunnyvale, CA 94086 408-737-7600**

© 2001 Maxim Integrated Products

Printed USA

MAXIM is a registered trademark of Maxim Integrated Products.