

REVISION(S)			
LTR	DESCRIPTION	INIT	APP'D
O	ECN: 0S60-0126-04	E.T 05/10/04	B.P 5/12/04
A	ECN: 0S60-0181-04	E.T 7/12/04	B.P 7/14/04
B	ECR-06-014978	E.T 6/28/06	V.K 6/28/06

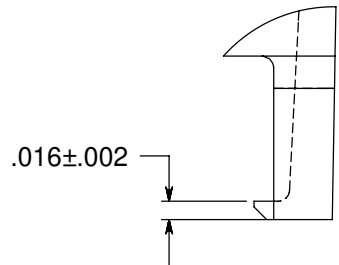

DETAIL A
SCALE = 6X

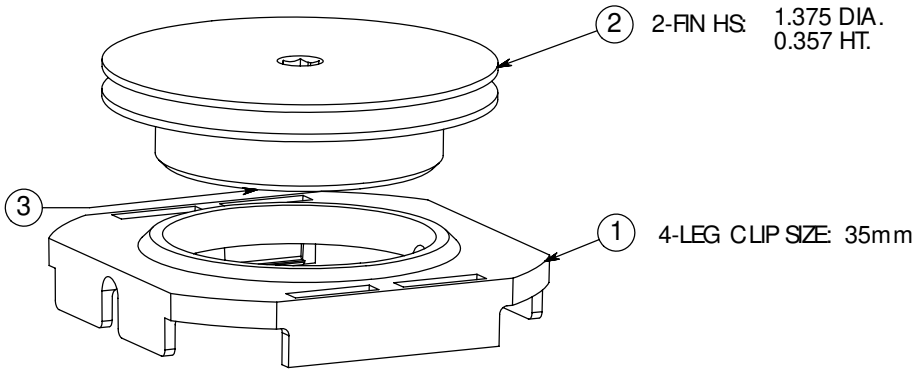
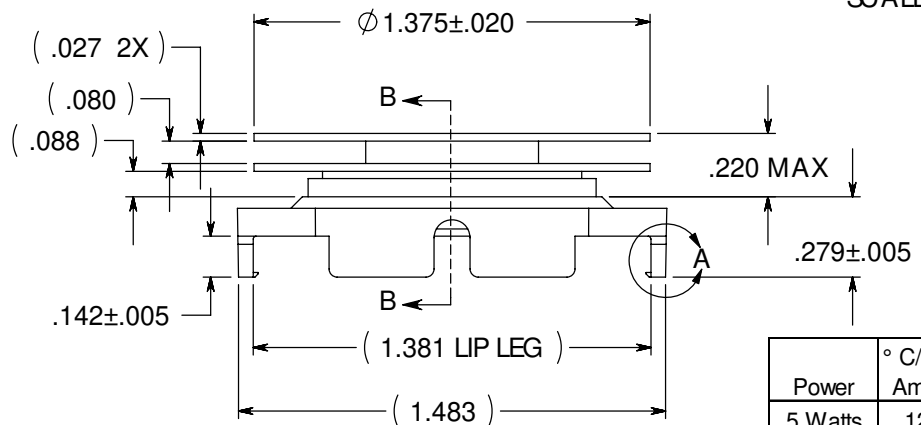

- MATERIAL:
HEAT SINK: ALUM. (BLACK ANODIZE)
CLIP: BLACK PEI (UL94-VO)
- BEFORE THE HEATSINK APPLICATION, THE USER SHOULD IDENTIFY THE SPECIFICATION OF MAXIMUM LOAD ON THE BGA PACKAGE.

HEATSINK TORQUE SPECIFICATIONS CONVERTED TO FORCE.

BARE DIE PACKAGE:
2.0 POUND-FORCE INCH TORQUE = 8.1 POUND-FORCE (0.23 NEWTON METER TORQUE = 36.03 NEWTON)
2.5 POUND-FORCE INCH TORQUE = 10.1 POUND-FORCE (0.28 NEWTON METER TORQUE = 44.93 NEWTON)

FULL SIZE LID PACKAGE:
2.0 POUND-FORCE INCH TORQUE = 6.9 POUND-FORCE (0.23 NEWTON METER TORQUE = 30.69 NEWTON)
2.5 POUND-FORCE INCH TORQUE = 8.7 POUND-FORCE (0.28 NEWTON METER TORQUE = 38.70 NEWTON)
- REMOVE CLIP WITH REMOVAL TOOL P/N: 1542616-1
- RoHS COMPLIANT AND CERTIFIED.

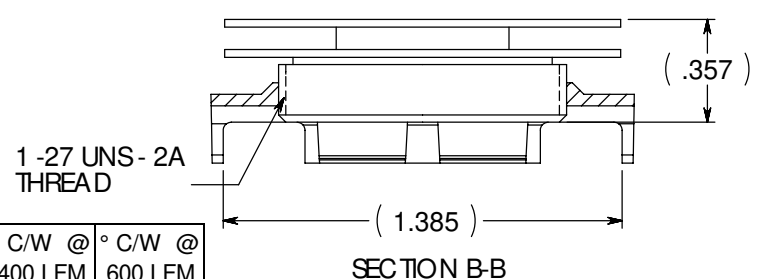

Power	° C/W @ Ambient	° C/W @ 200 LFM	° C/W @ 400 LFM	° C/W @ 600 LFM
5 Watts	12.04	6.32	4.30	3.00
10 Watts	10.94	6.44	4.49	3.24
15 Watts	10.07	6.44	4.59	3.26

CUSTOMER DRAWING

SPECIFICATIONS ARE SUBJECT TO CHANGE WITHOUT NOTICE

ITEM	DESCRIPTION	QTY
1	MOUNTING CLIP	1
2	HEAT SINK	1
3	INTERFACE	1

DO NOT SCALE	tyco / Electronics			Atteboro Falls Massachusetts 02763		CONFIDENTIAL PROPERTY OF TYCO ELECTRONICS NOT TO BE DISCLOSED TO OTHERS REPRODUCED OR USED FOR ANY PURPOSES EXCEPT AS AUTHORIZED IN WRITING BY AN AUTHORIZED OFFICIAL OF TYCO. MUST BE RETURNED TO TYCO ON DEMAND, ON COMPLETION OF ORDERS OR OTHER PURPOSES FOR WHICH LENT.		TITLE 35mm HEATSINK ASSEMBLY (HTS306-U)			
	UNLESS OTHERWISE SPECIFIED TO LEFTRANCES ARE:		DRAWN BY: ETAO	DATE 05/10/04	MATERIAL: SEE NOTE		DIMENSIONS ARE IN: INCHES		SCALE: 1.5:1	PART NO.: 6-1542001-7	SHEET: 1 OF 1
	.XX ± .XXX ± .XXXX ± ANGLES ± °		ENGINEER: B.PETROCELLI	DATE 5/12/04	FINISH: SEE NOTE		SIZE: A		DWG. NO. C-6-1542001-7	REV: B	
			FILENAME	PROJECT	SYSTEM						