

**BMA FEMALE-SMA FEMALE STRAIGHT ADAPTER
FLOATING FLANGE MOUNT**

R191.353.701

Série : ADAPT

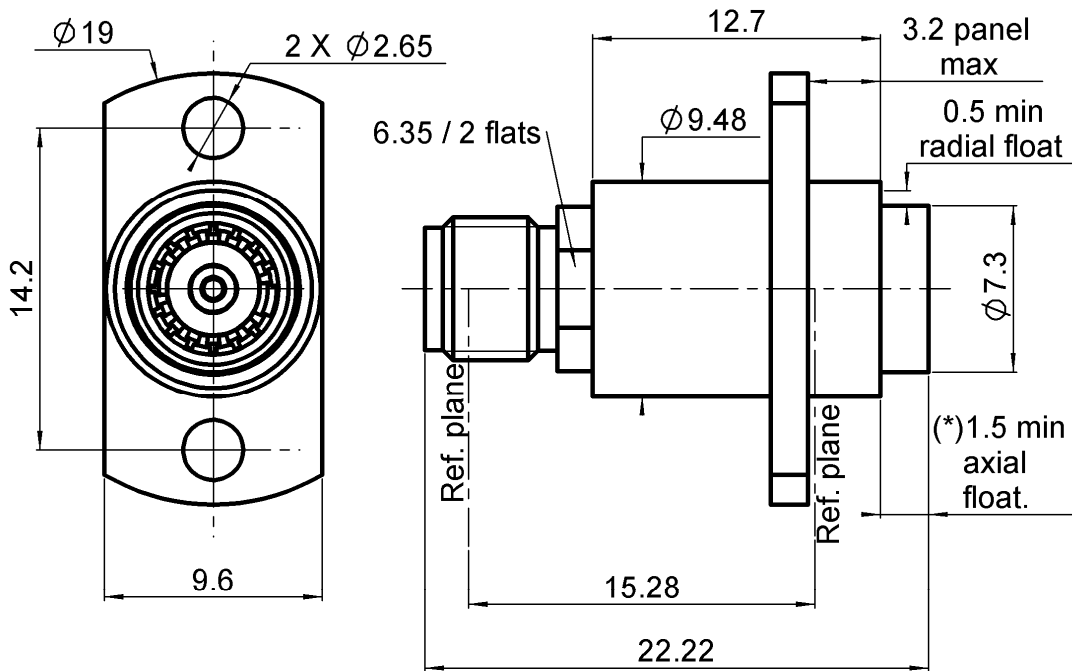

(*) Recommended axial float mount for best electrical performance: 0.51 +/- 0.25 mm (.020" +/- .010)

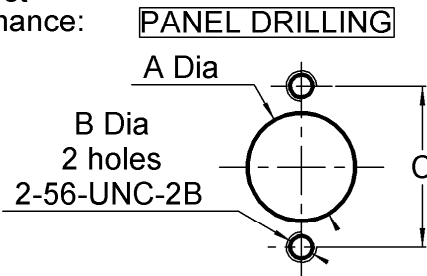
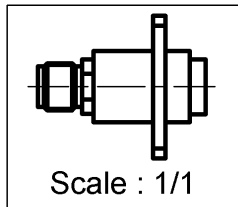

	maxi	mini
A	9.6	9.55
C	14.3	14.1

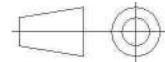
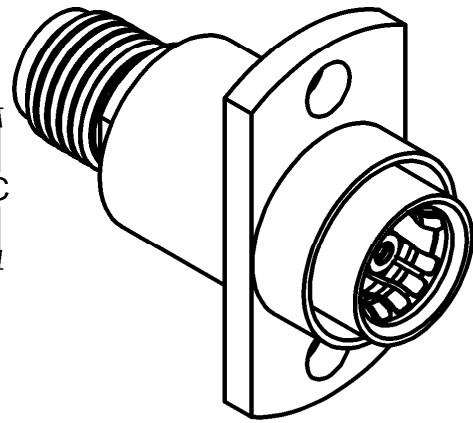

All dimensions are in mm.

COMPONENTS	MATERIALS	PLATING (µm)
BODY	STAINLESS STEEL	PASSIVATED
CENTER CONTACT	BERYLLIUM COPPER	GOLD 1.3 OVER NICKEL2
OUTER CONTACT	BERYLLIUM COPPER	NPGR
INSULATOR	PTFE	
GASKET	-	
OTHERS PARTS	BRASS	NICKEL 2
-	-	-
-	-	-

Issue : 0941 B

In the effort to improve our products, we reserve the rights to make changes judged to be necessary.



BMA FEMALE-SMA FEMALE STRAIGHT ADAPTER

R191.353.701

FLOATING FLANGE MOUNT

Série : ADAPT

PACKAGING

SPECIFICATION

Standard	Unit	Other
1	-	Contact us

ELECTRICAL CHARACTERISTICS

ENVIRONMENTAL

Impedance		50 Ω
Frequency		0-18 GHz
VSWR	1.06 +	0,0100 x F(GHz) Maxi
Insertion loss		0.03 √F(GHz) dB Maxi
RF leakage	- (80 - F(GHz)) dB Maxi
Voltage rating		350 Veff Maxi
Dielectric withstanding voltage		1000 Veff mini
Insulation resistance		5000 MΩ mini

Operating	-65/+165 °C
Hermetic seal	NA Atm.cm3/s
Panel leakage	NA

MECHANICAL CHARACTERISTICS

OTHER CHARACTERISTICS

Center contact retention		
Axial force – Mating end		27 N mini
Axial force – Opposite end		27 N mini
Torque		NA N.cm mini
Recommended torque		
Mating	BMA	0 N.cm
	SMA	0 N.cm
		0 N.cm
Panel nut		N.cm
Mating life		1000 Cycles mini
Weight		4,2700 g

Issue : 0941 B

In the effort to improve our products, we reserve the rights to make changes judged to be necessary.

