



MADE IN THE USA

Related Products (each sold separately):

- GB-001: Glove Box Dispenser - Single with Flexible Spring
- GB-003: Glove Box Dispenser - Triple (shown below)
- GB-059: Glove Box Dispenser - Quad



Product Description:

- Glove Box Dispenser - Double
- Holds two boxes of gloves
- Two-way keyholes for vertical or horizontal wall mounting
- White Powder-Coated Steel

Primary Area for Product Usage:

- Anywhere gloves are needed

Dispenses:

- Box(es) no larger than 5.25"W x 10.00"H x 3.75"D (13.3 cm x 25.4 cm x 9.5 cm)
- Box(es) no smaller than 3.60"W x 8.50"H x 3.00"D (9.1 cm x 21.6 cm x 7.6 cm)

Package Specifications:

- Package Quantity: 6 per case
- 16"L x 12"W x 12"H (40.6 cm x 30.5 cm x 30.5 cm)
- 12.0 lbs (5.4 kg) - approximated

Product Specifications (overall external dimensions):

- 10.56"W x 10.03"H x 3.81"D (26.8 cm x 25.5 cm x 9.7 cm)
- 1.6 lbs (0.7 kg) - approximated

Mounting Specifications:

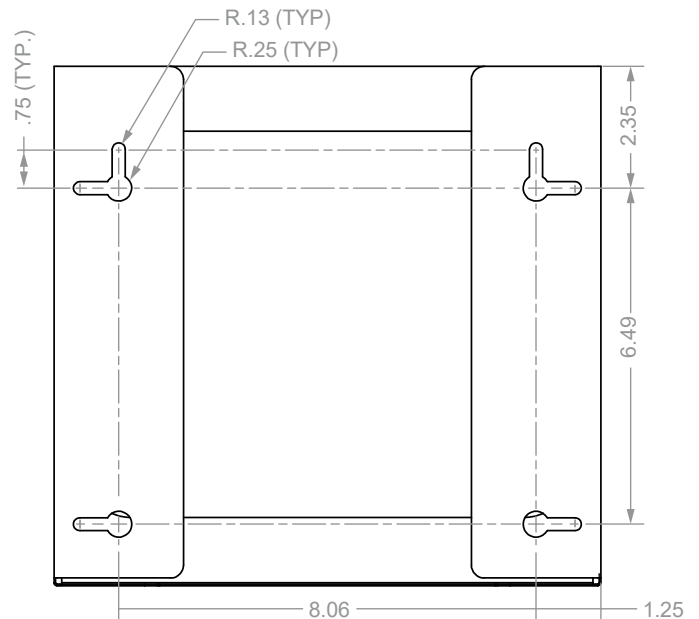



Installation

Always mount dispensers securely *prior* to loading with product.

- Open face design allows for either two boxes of gloves side-by-side or one large box of other PPE products.

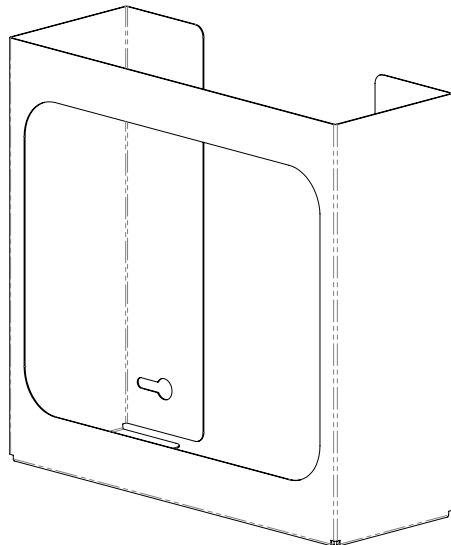

- Mount securely to a wall with screws approved and supplied by building maintenance.

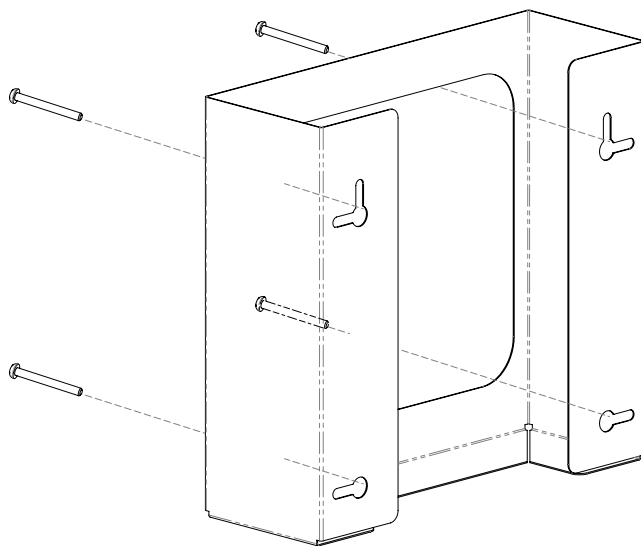

Parts included:

- Dispenser

Tools Required:

- No tools required to assemble dispenser

Care and Construction

Powder-Coated Steel

Material Characteristics

Designed for Long-Term, Heavy-Duty Applications

Dispensers and stands made of powder-coated steel are both attractive and functional, providing years of service. Our powder-coated steel dispensers and stands provide long-lasting products that hold up well in tough environments.

Powder-coated steel is ideal for dispensers used in a healthcare or an industrial setting. It is impact resistant and is not effected by extremes in temperature.

Care and Cleaning

The powder-coated finish resists common chemicals and cleaning agents and can be easily wiped clean with soap and water.