

**NOTES:**

1. FOR WAVESOLDERING (SOLDER BATH TEMPERATURE 265°C FOR 8 SEC. AND SOLDER PREHEAT 150°C FOR 180 SEC.)
2. IP RATING: IP 67
3. SEALED TO WITHSTAND PRESSURE UP TO 1,45 PSI FOR 30 MINUTES AFTER HIGH TEMPERATURE EXPOSURE
4. METAL SHELL:  
ZINC DIE CAST; min. 50µin NICKEL PLATING over COPPER
5. INSULATORS: PBT GF UL 94 V-0, BLACK
6. O-RING: SILICONE PER ASTM D2000 70 SHORE A
7. RUBBER GASKET: TPE
8. SEALING COMPOUND: EPOXY RESIN UL 94 V-0; BLACK
9. CONTACTS: COPPER ALLOY  
PLATING (SEE PART NO):  
 PLEASE ADD 1 for 30µin HARD GOLD over min. 50µin NICKEL  
 PLEASE ADD 3 for 8µin HARD GOLD over min. 50µin NICKEL
10. METAL BRACKETS: ZINC DIE CAST; 300µin COPPER/40-120µin NICKEL/120-200µin TIN
11. WASHERS: COPPER ALLOY; 80µin NICKEL
12. HEXLOCKING SCREWS: STAINLESS STEEL
13. PCB-SNAPS: COPPER ALLOY; min. 200µin TIN over 80µin NICKEL  
PCB-HOLE:  $\varnothing 3.1 \pm 0.1$ ; PCB THICKNESS 1.6mm
14. P.C.B. HOLE DRILLINGS and RECOMMENDED PANEL CUT-OUT ON SHEET 2
15. RECOMMENDED TORQUE FOR MOUNTING SCREW 35Ncm (3.1 in.LB) / max.67Ncm (6 in.LB)
16. CONNECTOR IS PART MARKED: 15-00083 CONEC ABC

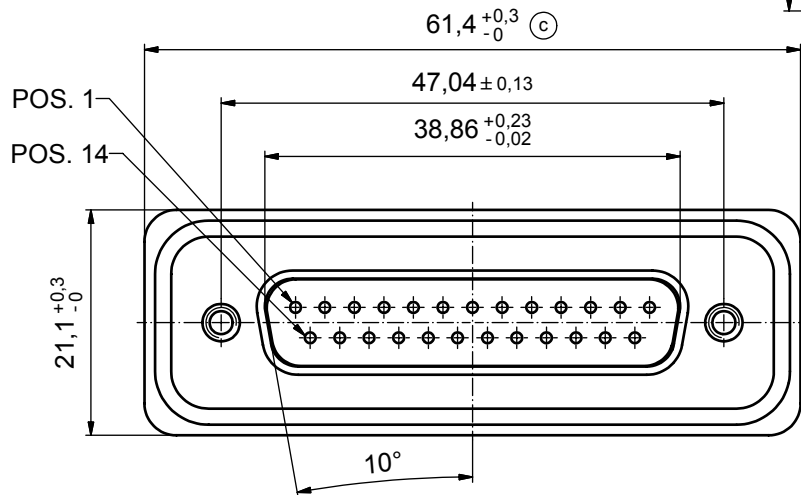

RUBBER GASKET PLACED ON TOP SURFACE OF MALE INSULATOR

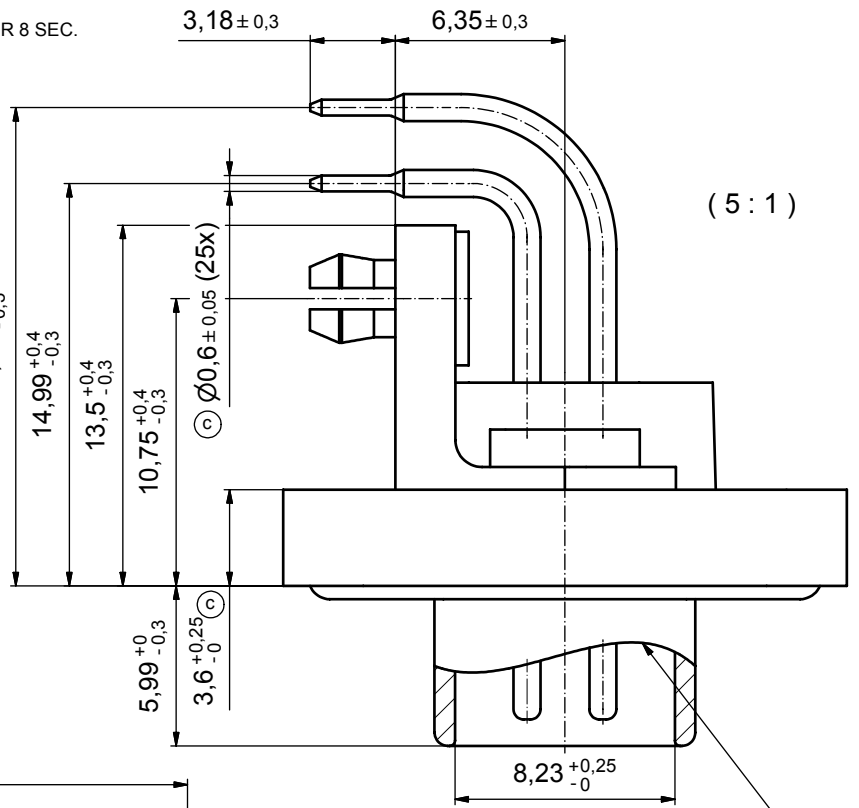
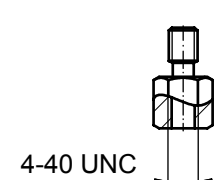
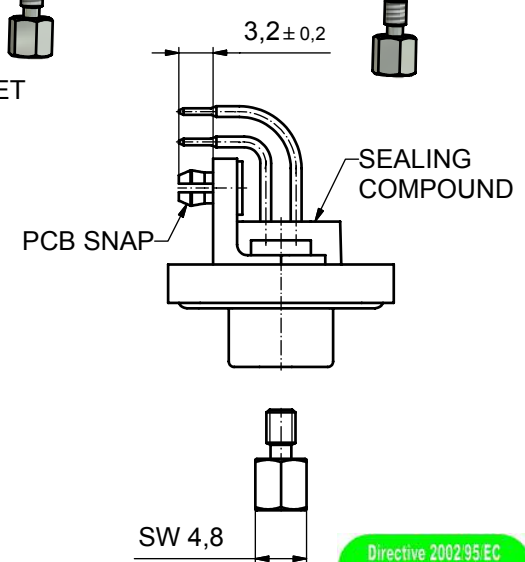
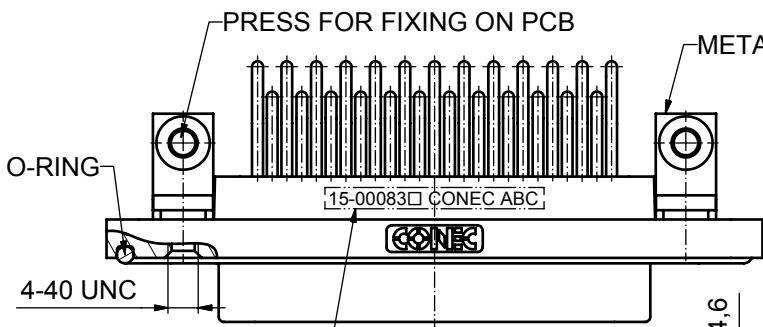
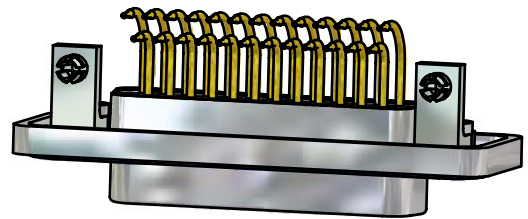

SEE NOTE 16

AT ALL TIMES WATER RESISTANT CONNECTORS NOT IN USE SHOULD BE COVERED WITH A CONEC WATER RESISTANT CAP OR WATER TIGHT HOOD.



APPROVAL # FREIGABE # DEBLOCAGE # AUTORIZACION # APPROVAL	
CUSTOMER APPROVAL DATE:	
NAME:	TITLE:
COMPANY NAME:	
APPROVAL # FREIGABE # DEBLOCAGE # AUTORIZACION # APPROVAL	

tolerance				dim. in mm	scale: 2:1 (5:1)	
date					material: see notes	
drawn				name	title:	
17.10.08					D-SUB MALE 90°	
appd.				norm	25pos. SOLDER PIN ANGLED	
23.10.08					with metal bracket, hexlocking screw and snap	
d-old				dwg no: Inventor 10		DIN-A3
4 x c	A 3435	08.10.09	HS	15K1A301		sh: 1
a	Origin			part no: 15-00083 (see note 9)		



