

THIS DRAWING IS SUPPLIED FOR INFORMATION ONLY. DESIGN FEATURES, SPECIFICATIONS AND PERFORMANCE DATA SHOWN HEREON ARE THE PROPERTY OF THE AMPHENOL CORPORATION. NO RIGHTS OF REPRODUCTION ARE IMPLIED. ALL DIMENSIONS ARE SUBJECT TO NORMAL MANUFACTURING VARIATIONS.

Customer Drawing

REVISIONS					
REV	ZONE	ECO	DESCRIPTION	DATE	BY APPR
A	--	--	Change design	04/11/14	RW EC
G	--	--	Add Dust Cap & Change HVL Wire, Update Spec.	03/30/16	RW GX
H	--	--	Add Geometric Tolerance of Flange & Panel	03/30/16	RW GX
i	--	--	Change Shell and Gasket	05/09/17	Sam Julie

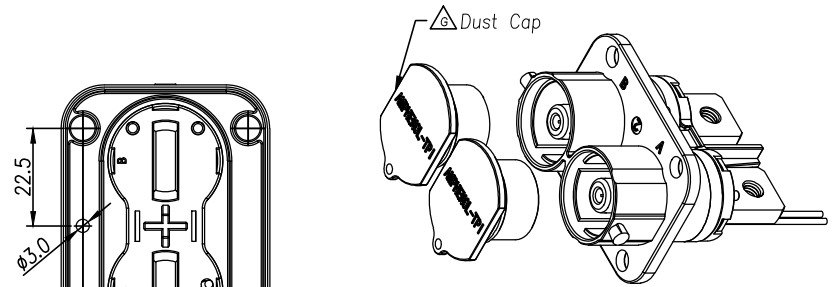
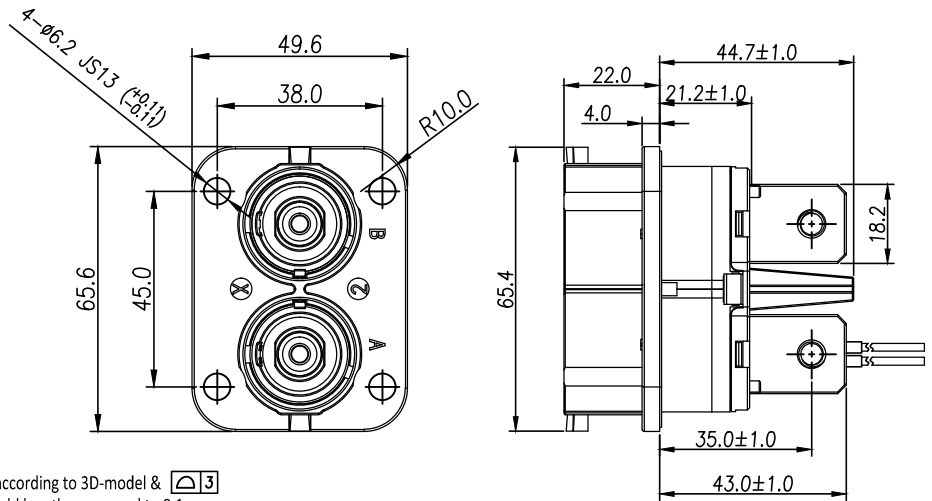

- Notices:
- All non-dimensioned surfaces according to 3D-model &
 - Planeness of panel surface should less than or equal to 0.1mm
 - Roughness of panel surface should be $\sqrt{0.1}$ or better.
 - Thickness of panel should not exceed 12mm.

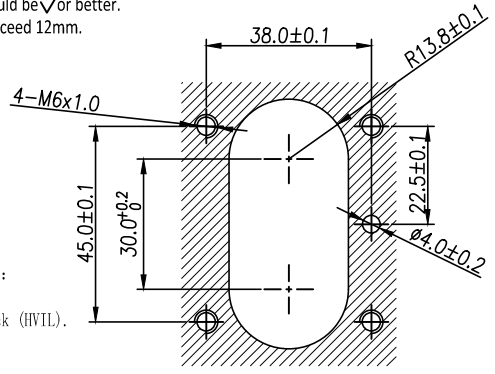

- 规格参数 (Spec.):
- 工作温度 Operating temperature: -40° C ~ +125° C.
 - 带高压互锁 Electrical interlock (HVIL).
 - 额定电流 Current rating: Power: 300A; HVIL: 5A.
 - 额定电压 Operating voltage: Power: 1000 VDC; Signal: 60 VDC.
 - 耐电压 Dielectric withstanding voltage:
 - 与插头对插后, Pin与铁壳之间 After mating, between pin and metal shell :5000 VDC.
 - 与插头对插后, Pin与HVIL之间 After mating, between pin and HVIL :5000 VDC.
 - 与插头对插后, HVIL与铁壳之间 After mating, between HVIL and metal shell :500 VDC.
 - 与插头对插前, 两个HVIL端子之间耐压 Before mating, between two HVIL terminals :500 VDC.

面板安装孔尺寸
Panel Size

订购信息 Ordering Information

PL082 X	- 30	1	- 10	D	8
键位及颜色 Key	高压互锁 HVIL	孔种类 Hole Type	联接螺栓 Bolt Size		
"X" Key	0, 不带互锁 No HVIL	D, 通孔 Through Hole	Customer Define		
"Y" Key	1, 带互锁 With HVIL	M, 螺孔 Screw Hole			
		H, 腰孔 Slotted Hole			

- 防护等级 Protection class: IP67 & IP2X.
- 电磁屏蔽 Shielding.
- 机械寿命 Mating cycle: 50 Min.
- 带自动二次锁扣 Automatic secondary lock.
- 铜排推荐安装扭矩 Recommended Fasten Torque on Lug:
 - M6 : 3.6~4.4 Nm
 - M8 : 7.2~8.8 Nm
 - M10: 17.1~20.9 Nm
- 推荐法兰盘螺丝安装扭矩 Recommended Screw Assembly Torque on Flange : 6.2~7.6 Nm

Standard Part List (With HVIL)

P/N	Model NO.	Mating Plug Model NO.
AC-HA000799	PL082X-301-10D10	PL182X-301-XX, PL282X-301-XX
AC-HA000800	PL082Y-301-10D10	PL182Y-301-XX, PL282Y-301-XX
AC-HA000803	PL082X-301-10D8	PL182X-301-XX, PL282X-301-XX
AC-HA000804	PL082Y-301-10D8	PL182Y-301-XX, PL282Y-301-XX
AC-HA000805	PL082X-301-10M8	PL182X-301-XX, PL282X-301-XX
AC-HA000806	PL082Y-301-10M8	PL182Y-301-XX, PL282Y-301-XX
AC-HA001208	PL082X-301-10M6	PL182X-301-XX, PL282X-301-XX
AC-HA001209	PL082Y-301-10M6	PL182Y-301-XX, PL282Y-301-XX

Standard Part List (Without HVIL)

P/N	Model NO.	Mating Plug Model NO.
AC-HA000807	PL082X-300-10D10	PL182X-300-XX, PL282X-300-XX
AC-HA000808	PL082Y-300-10D10	PL182Y-300-XX, PL282Y-300-XX
AC-HA000811	PL082X-300-10D8	PL182X-300-XX, PL282X-300-XX
AC-HA000812	PL082Y-300-10D8	PL182Y-300-XX, PL282Y-300-XX
AC-HA000813	PL082X-300-10M8	PL182X-300-XX, PL282X-300-XX
AC-HA000814	PL082Y-300-10M8	PL182Y-300-XX, PL282Y-300-XX
AC-HA001212	PL082X-300-10M6	PL182X-300-XX, PL282X-300-XX
AC-HA001213	PL082Y-300-10M6	PL182Y-300-XX, PL282Y-300-XX



Amphenol Technical Products International GZ

第三角投影 THIRD ANGLE PROJECTION	页面 SHEET	幅面 SIZE	版次 REV.	比例 SCALE	PART NAME: PwrLok 10mm 2POS Rcpt Conn
	1 of 1	A3	1		DWG NO: PL082-300-10
UNLESS OTHERWISE SPECIFIED 1) All dimensions are in metric(mm). 2) Tolerances are as follows: 0 PL DEC ±1.00 1 PL DEC ±0.50 2 PL DEC ±0.20	签名 SIGNATURE 日期 DATE 05/09/17	审核 CHECKED Julie 05/09/17	批准 APPROVAL Haley 05/09/17	角度 Angles ±1°	CUST PART #: N/A