

PART NUMBER	REV	FIRST USED
466091-1	C	122500-1

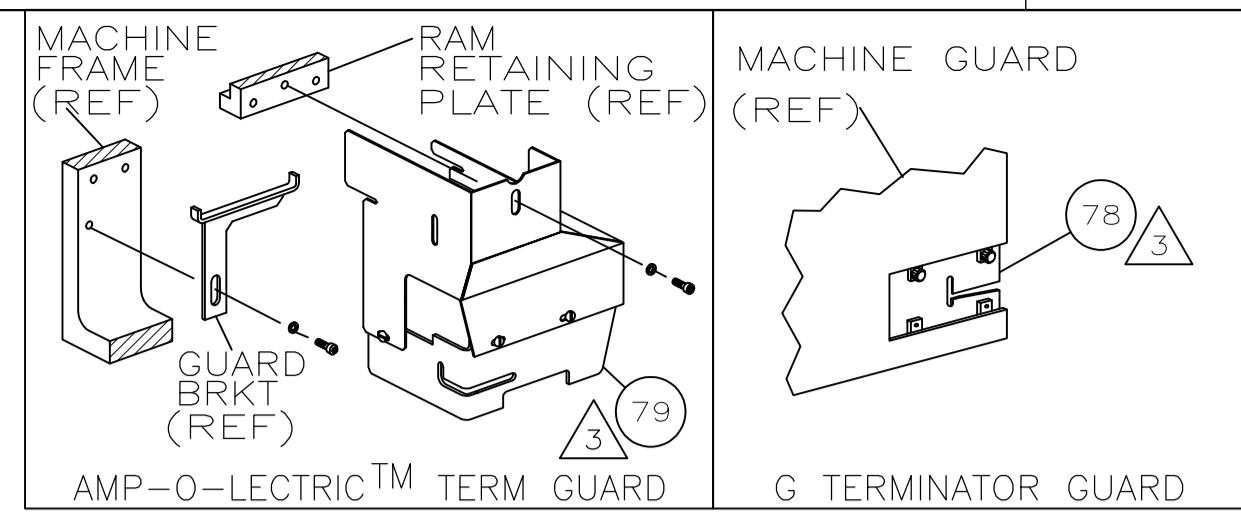

TERMINAL NAME: .205 FASTON RECP					
AMP TERMINAL		AMP CRIMP SPECS			
60674					
1742754					
PAD LTR	CRIMP HEIGHT	WIRE SIZE			
A	.038 ±.002 [0.97 ±0.05mm]	22			
B	.035 ±.002 [0.89 ±0.05mm]	24			
C	.033 ±.002 [0.84 ±0.05mm]	26			
D	NOT	USED			
CRIMP	SIZE	TYPE	RANGE		
WIRE	.055 [1.40mm]	F	26-22		
INSUL	.080 [2.03mm]	F	26-.070		
WIRE STRIP LENGTH	TERM APPL SPEC	FEED	APPL INSTRUCTION	SET UP GAGE	LAYOUT
.205-.235	114-2036	.689	408-8039	458638-1	-

-1	LEADMAKER & BENCH MODEL G	MECH POST FEED
----	---------------------------	----------------

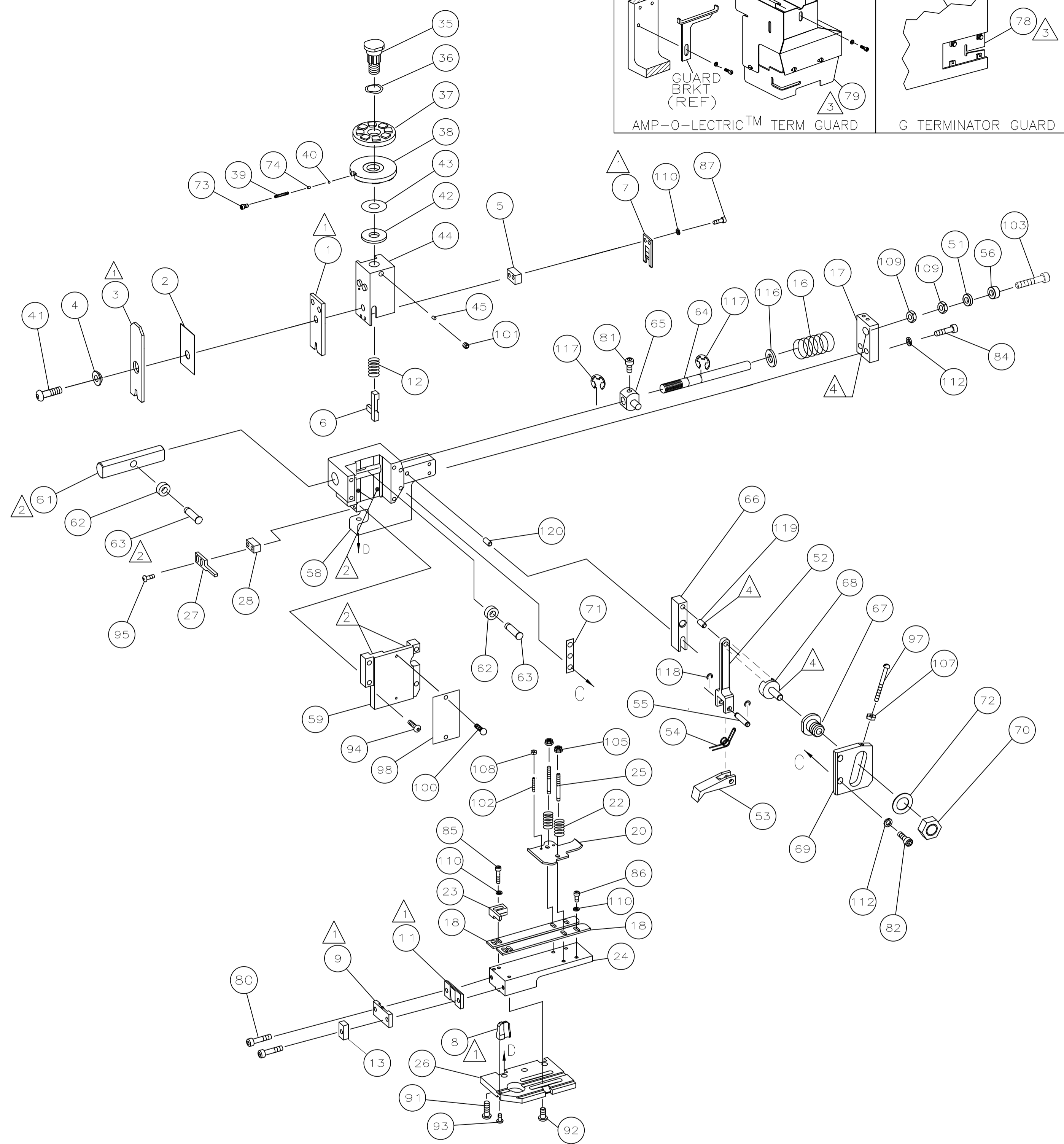

REF	QTY	DESCRIPTION	ITEM NO
			129
			128
			127
			126
			125
1	-	A 217238-1 GENERAL INSTRUCTION PACKAGE	124
1	-	- 4088039 EF APPL INST 408-8039	123
			122
			121
REF	-	A 1-21030-6 PIN,DOWEL(Ø.187x1.25)HSG	120
REF	-	A 1-21030-1 PIN,DOWEL(Ø.187x.50)LEVER	119
REF	-	A 21045-3 RING,RET"C"(Ø.187)FD PIN	118
REF	-	A 1-21046-6 RING,RETAINING,EXT(5/16)FD ADJ ROD	117
REF	-	A 21899-4 WASHER,FLAT(Ø5/16)SCR ADJ	116
			115
			114
			113
REF	-	A 21024-5 WASHER,LOCK(NO.10)FD ROD GDE	112
			111
7	-	A 21024-4 WASHER,LOCK(NO.8)SHEAR BL	110
REF	-	A 22593-1 NUT,HEX(1/4-20)MAGNET	109
2	-	A 21018-4 NUT,HEX(4-40)DRAG	108
REF	-	A 21018-5 NUT,HEX(6-32)FD ADJ PL	107
			106
2	-	A 21022-2 NUT,HEX SL(8-32)DRAG STUD	105
			104
REF	-	A 3-21081-3 SCR,SHC(1/4-20x1.25)MAGNET	103
2	-	A 2-21006-6 SCR,SKT SET(4-40x.62)DRAG	102
1	-	A 21009-2 SCR,SKT SET(1/4-20x.25)RAM	101
2	-	A 21017-2 SCR,DRIVE(#2x.19)ID PLATE	100
1	-	A 1-21002-7 SCR,BHC(6-32x.38)CAM	99
1	-	B 461264-1 PLATE, IDENTIFICATION	98
REF	-	A 6-23715-5 SCR,PAN HD(6-32x1.50)FEED ADJ	97
			96
2	-	A 2-21002-2 SCR,BHC(8-32x.50)STRIPPER	95
REF	-	A 2-21002-9 SCR,BHC(10-32x.75)HSG CAP	94
1	-	A 22733-8 SCR,BHC(8-32x.38 LW)ANVIL	93
4	-	A 3-21002-3 SCR,BHC(1/4-20x.50)ST GD PL	92
REF	-	A 2-22733-8 SCR,BHC(1/4-20x.62)BASE PL	91
			90
			89
			88
2	-	A 2-21000-6 SCR,SHC(8-32x.38)SLUG BLADE	87
3	-	A 7-21000-4 SCR,SHC(8-32x.31)STRIP GUIDE	86
2	-	A 2-21000-8 SCR,SHC(8-32x.62)R STRIP GUIDE	85
REF	-	A 3-21000-7 SCR,SHC(10-32x.75)FEED ROD GDE	84
			83
REF	-	A 3-21000-6 SCR,SHC(10-32x.62)FEED ADJ PL	82
REF	-	A 3-21000-4 SCR,SHC(10-32x.38)PIVOT BLOCK	81
2	-	A 3-21000-8 SCR,SHC(10-32x.88)SHEAR PL	80
-	-	A 455745-1 GUARD, WINDOW	79
REF	-	A 679532-1 INSERT, GUARD	78
			77
			76
			75
1	-	A 690603-1 SPRING, ASSIST	74
1	-	A 23030-1 SCR,SKT CAP(6-32x.25)CP DSC	73
REF	-	A 458109-1 WASHER, FLAT (SPECIAL)	72
REF	-	A 690517-1 SPACER	71

REF	QTY	DESCRIPTION	ITEM NO
REF	-	A 22594-8 NUT, HEX	70
REF	-	B 240628-1 PLATE, ADJ	69
REF	-	B 240626-1 SHAFT, PIVOT	68
REF	-	B 240633-1 BUSHING	67
REF	-	A 455680-1 LEVER, INTERMEDIATE	66
REF	-	B 240629-1 BLOCK, PIVOT	65
REF	-	A 1804311-1 SCR, ADJ	64
REF	-	B 240659-3 PIN, CAM ROLLER	63
REF	-	B 240658-1 CAM, ROLLER	62
REF	-	B 454398-1 ROD, FEED	61
			60
REF	-	C 454220-1 CAP, RAM	59
REF	-	D 453736-1 HOUSING	58
			57
REF	-	A3 1804299-1 SPACER, MAGNET	56
REF	-	B 240624-1 PIN, FEED FINGER	55
REF	-	B 691499-1 SPRING, FEED FINGER	54
REF	-	B 240635-1 FINGER, FEED	53
REF	-	B 240634-1 LEVER, TERMINAL	52
REF	-	A 1804310-1 MAGNET, RING	51
			50
			49
			48
1	-	B 690501-4 CAM, POST-FEED 1 5/8 ST	47
			46
1	-	A 690191-1 PLUG, NYLON	45
1	-	C 455674-1 RAM	44
1	-	A 690125-1 WASHER, LAMINATED	43
1	-	A 690124-1 WASHER, RAM	42
1	-	A 7-21002-9 BOLT, CRIMPER(5/16-24x1.00)	41
1	-	A 23241-6 BALL, STEEL	40
1	-	A 690170-1 SPRING, COMPRESSION	39
1	-	C 690142-1 DISC, INSULATION	38
1	-	D 8-690692-6 DISC, WIRE	37
1	-	A 22480-5 WASHER, SPRING	36
1	-	B 690212-1 POST, RAM	35
			34
			33
1	-	D 458980-1 APPLICATOR, BASIC (SUB ASSY)	32
			31
			30
			29
1	-	B 3-690451-2 SPACER, STRIPPER	28
1	-	A 240639-1 STRIPPER	27
REF	-	C 455676-1 PLATE, BASE	26
2	-	A 22354-8 DRAG, STUD	25
1	-	B 455678-1 PLATE, STRIP GUIDE	24
1	-	C 240825-9 PLATE, STRIP HOLD DOWN	23
2	-	A 4-22281-1 SPRING, DRAG	22
			21
1	-	A 454177-1 DRAG, STOCK	20
			19
2	-	C 454204-6 GUIDE, STRIP (FRONT)	18
REF	-	A 1804305-2 GUIDE, FEED ROD	17
REF	-	A 6-22284-4 SPRING, FEED RETURN	16
			15
			14
1	-	C 690481-2 SPACER, HOLD DOWN	13
1	-	A 23846-1 SPRING, HOLD DOWN	12
1	-	B 240644-1 PLATE, REAR SHEAR	11
			10
1	-	B 690495-3 PLATE, FRONT SHEAR	9
1	-	D 6-240693-4 ANVIL	8
1	-	B 690474-5 BLADE, SLUG	7
1	-	D 3-455892-0 HOLD DOWN, TERMINAL	6
1	-	C 3-240641-7 SPACER, SLUG BLADE	5
1	-	B 238009-1 SPACER, BLOCK CRIMPER	4
1	-	C 1-456134-6 CRIMPER, INSULATION	3
1	-	B 455888-7 SPACER, CRIMPER	2
1	-	C 1-456402-6 CRIMPER, WIRE	1

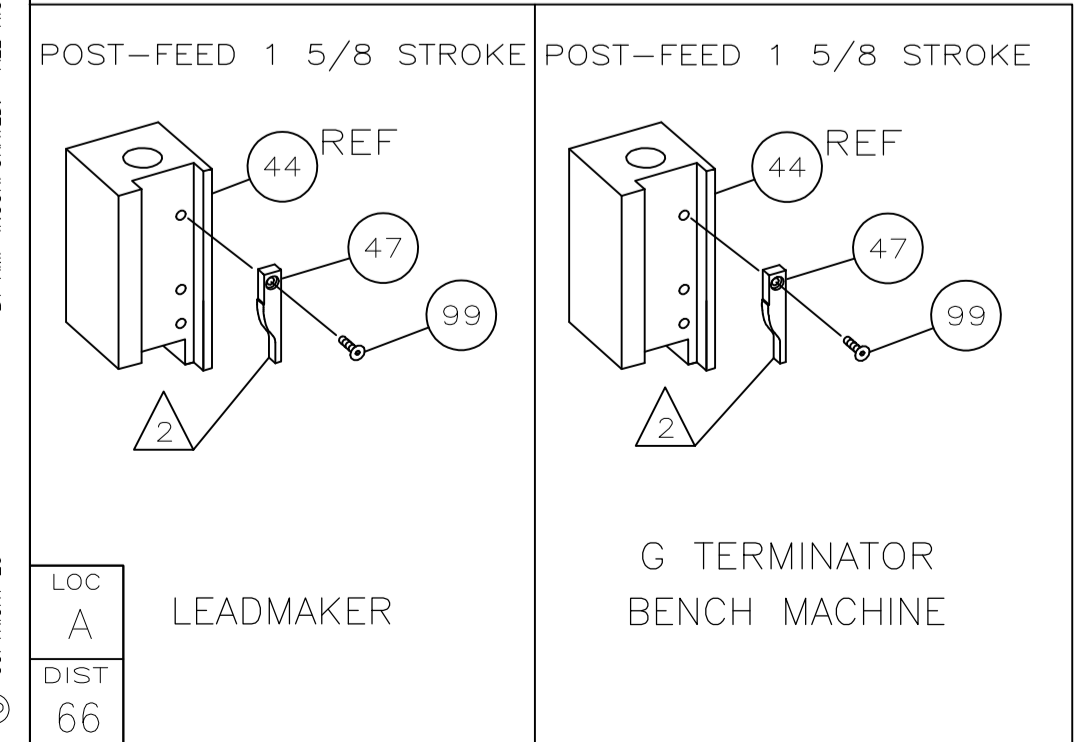

- 1 RECOMMENDED SPARE PARTS.
- 2 GREASE LIGHTLY.
- 3 GUARD MUST BE IN PLACE WHEN OPERATING APPLICATOR IN A BENCH MACHINE.
- 4 LUBRICATE DAILY USING NO. 20 MACHINE OIL.
- 5. ITEMS WITH QTY OF REF SPECIFIED (EXCEPT ITEMS 78 AND 79) ARE USED ON ITEM 32.
- 6 ITEM 78 USED WITH G TERMINATOR ONLY.

QTY REQD PER ASSY	U/M	DWG SIZE	PART NO	DESCRIPTION	ITEM NO

QTY REQD PER ASSY	U/M	DWG SIZE	PART NO	DESCRIPTION	ITEM NO

DIMENSIONS IN INCHES. DO NOT SCALE PRINT. TOLERANCES UNLESS OTHERWISE SPECIFIED:

DR C.ERISMAN 04APR06 APP T.ELBIN 04APR06
CHK 04APR06 C.ERISMAN REL -
NAME END FEED HDM APPLICATOR MACHINE REF MINI APPL
SCALE - DWG NO 466091-1 SHEET 1 OF 1 REV C

REMOVE BURRS, BREAK SHARP EDGES R.015 MAX

CAGE CODE 00779 CUSTOMER AND ASSEMBLY DRAWING

THIS DRAWING IS A CONTROLLED DOCUMENT.

THIS DRAWING IS UNPUBLISHED. RELEASE FOR PUBLICATION BY AMP INCORPORATED. ALL RIGHTS RESERVED. COPYRIGHT 2002