

PART NUMBER	REVISION	DESCRIPTION	FEED TYPE
2266127-1	C	FINE CRIMP HEIGHT ADJUST	MECHANICAL
2266127-2	C	FINE CRIMP HEIGHT ADJUST	PNEUMATIC
7-2266127-1	C	MECHANICAL AND CRIMP TOOLING KIT	MECHANICAL
7-2266127-2	C	PNEUMATIC AND CRIMP TOOLING KIT	PNEUMATIC
7-2266127-7	B	CRIMP TOOLING KIT	-
7-2266127-8	B	APPLICATOR CONVERSION KIT	-

ATLANTIC VERSION TERMINATOR INTERFACE ADAPTER

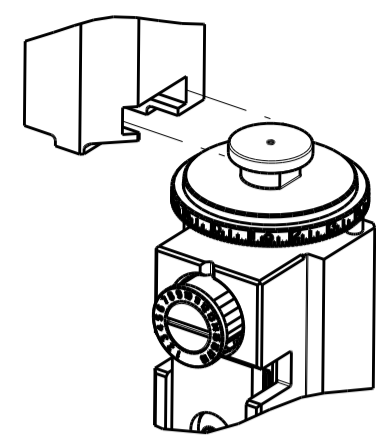

APPLICATOR DATA		
CRIMP	SIZE	TYPE
WIRE	3.28 mm [.129]	F
INSUL	4.83 mm [.190]	O

APPLICATOR INSTRUCTIONS
408-35042

APPLICATOR CONVERSION KITS	
PART NUMBER	INSULATION DIAMETER RANGE
7-2266127-8	Ø 4.65-5.18mm [.183-.204]
7-2266128-8	Ø 3.96-4.62mm [.156-.182]
7-2266129-8	Ø 3.56-3.94mm [.140-.155]

TERMINAL DATA: DEUTSCH TERMINAL		TE CRIMP SPECIFICATION	
TERMINAL NAME: STAMPED CONTACT PIN SIZE 12			
WIRE STRIP LENGTH	INSULATION DIAMETER RANGE		
5.71-6.99 mm [.225-.275 IN]	Ø 4.65-5.18 mm [.183-.204 IN]		
TERMINAL APPLICATION SPECIFICATION	114-151006		
TERMINALS APPLIED			
TE TERMINAL	DEUTSCH TERMINAL	TE TERMINAL	DEUTSCH TERMINAL
286989-1	1060-12-0222	286989-2	1060-12-0244

TERMINAL DATA: DEUTSCH TERMINAL		TE CRIMP SPECIFICATION	
TERMINAL NAME: STAMPED CONTACT SOCKET SIZE 12			
WIRE STRIP LENGTH	INSULATION DIAMETER RANGE		
5.71-6.99 mm [.225-.275 IN]	Ø 4.65-5.18 mm [.183-.204 IN]		
TERMINAL APPLICATION SPECIFICATION	114-151006		
TERMINALS APPLIED			
TE TERMINAL	DEUTSCH TERMINAL	TE TERMINAL	DEUTSCH TERMINAL
286988-1	1062-12-0222	286988-2	1062-12-0244

WIRE SIZE	CRIMP HEIGHT mm [INCH]	CRIMP HEIGHT REFERENCE SETTING
6.00mm2	2.72+0.03/-0.05 [.107+.001/- .002]	5.4
10 AWG	2.51+0.03/-0.05 [.099+.001/- .002]	7.6
5.00mm2	2.51+0.03/-0.05 [.099+.001/- .002]	7.5
4.00mm2	2.16+0.03/-0.05 [.085+.001/- .002]	11.0



- 1 RECOMMENDED SPARE PARTS
- 2 REFER TO SUPPLIED INSTRUCTION SHEET FOR CLEANING, LUBRICATION AND STORAGE OF APPLICATOR.
- 3 APPLY PART NUMBER 2-23419-6 LOCTITE TO THREADS OF ITEM 242.
- 4 CRIMP HEIGHT REFERENCE SETTING WAS THE SETTING USED WHEN THE APPLICATOR WAS QUALIFIED AT THE FACTORY. ADJUSTMENT MAY BE NECESSARY WHEN RUNNING APPLICATOR IN THE FIELD.
- 5. UNLESS SPECIFIED OTHERWISE TORQUE VALUES SHALL BE USED PER DOCUMENT, 101-35000.
- 6 WHEN ASSEMBLING A NON CRIMP HEIGHT ADJUST APPLICATOR (-6) USE SHIMS FROM ITEM 260 TO ACHIEVE A NOMINAL SHIM HEIGHT OF 3.08.
- 7 DIMENSION 2.0±0.5 APPLIES TO PIN TERMINALS 1060-12-02XX.
- 8 DIMENSION 7.9±0.5 APPLIES TO SOCKET TERMINALS 1062-12-02XX.
- 9 CUT TO LENGTH AT ASSEMBLY.
- 10 SEE APPROPRIATE APPLICATOR LOG SHEETS FOR APPLIED TERMINALS, WIRE RANGE AND MEMORY CHIP.
- 11 TERMINAL LUBRICANT IS RECOMMENDED.

***WARNING**
ON INSTALLATION, SET WIRE DISC TO CRIMP HEIGHT REFERENCE SETTING FOR LARGEST WIRE SIZE. CRIMP HEIGHT REFERENCE SETTINGS GREATER THAN THE VALUE SHOWN MAY CAUSE DAMAGE TO THE CRIMP TOOLING, REFER TO THE INSTRUCTION SHEET FOR PROPER SETUP AND ADJUSTMENTS.

LOC	DIST	REV	DATE	BY	CHK
A	66	B	13JAN2016	JH	GB
		B1	12DEC2016	RS	LZ
		B2	09JAN2018	KH	GB
		C	10JUL2019	FJ	TE

REV	DATE	BY	CHK	DESCRIPTION	ITEM NO		
-	-	1	1	1	2119791-9	DEPRESSOR, WIRE	265
-	-	1	-	1	2119641-1	FEED CAM, AIR FEED	248
-	-	1	1	1	2119082-9	CAM, SNAIL, INSULATION ADJUSTMENT	244
-	-	1	1	1	2079764-1	WASHER, WAVE SPRING, CREST-TO-CREST	243
-	-	1	1	1	2119083-1	RETAINER, INSULATION DIAL	242
-	-	1	1	1	7-18023-7	SCR, SKT HD CAP M3 X 4.0	241
-	-	-	1	-	2119580-1	MECHANICAL FEED ASSEMBLY	239
-	-	1	-	1	2844940-1	AIR FEED MODULE	238
-	-	REF	REF	REF	994970-2	COUNTER, MAGNETIC	164
-	-	1	1	1	1-18028-2	WASHER, FLAT, REG M4	119
-	-	1	1	1	2119955-1	ASSY, LUBRICATOR, SIDE FEED	113
-	-	1	1	1	2844908-1	SCREW, LOCKING	99
-	-	1	1	1	2844907-1	POST, LOCKING	98
-	-	1	1	1	455888-5	SPACER, CRIMPER	82
1	-	-	-	-	2266127	PRINT, APPLICATOR LOG SHEET	72
-	-	1	1	1	1803607-3	DOCUMENTATION PACKAGE	71
-	-	1	1	1	2119791-9	DEPRESSOR, WIRE	70
-	-	1	1	1	2119740-1	TAG, IDENTIFICATION	67
-	-	2	2	2	2168078-1	SCREW, DRIVE, RH, RoHS, 2 x .188	66
-	-	1	1	1	2168083-2	SCR, SKT HD CAP, RoHS, M4 X 8.0	60
-	-	1	1	1	5-18022-5	SCR, HEX HD CAP, M4 X 6.0	59
-	-	1	1	1	1338685-1	PAWL, FEED	56
-	-	4	4	4	2168083-3	SCR, SKT HD CAP, RoHS, M4 X 12.0	54
-	-	2	2	2	2168083-3	SCR, SKT HD CAP, RoHS, M4 X 12.0	53
-	-	1	1	1	5018030-1	NUT, HEX, REG, RoHS, M3	52
-	-	1	1	1	811242-5	BUMPER, HOLD DOWN	51
-	-	1	1	1	690753-2	SPACER, TONKER	50
-	-	1	2	1	18023-9	SCR, SKT HD CAP M4 X 6.0	49
-	-	-	1	-	2119652-1	FEED CAM, PRE FEED	48
-	-	-	1	-	2119653-1	FEED CAM, POST FEED	47
-	-	1	1	1	1803583-9	APPLICATOR BASIC ASSEMBLY, SF	46
-	-	1	1	1	1803515-1	RAM ASSEMBLY, SF ATLANTIC	44
-	-	1	1	1	1803602-1	SCR, BHSC, RoHS (M8 X 25)	41
-	-	1	1	1	1752356-6	SUPPORT, TERMINAL	34
-	-	2	2	2	2079383-5	SCR, BHSC, RoHS (M4 X 20)	33
-	-	2	2	2	2-2844962-8	SPACER, CYLINDRICAL, STRIP GUIDE	30
-	-	1	1	1	2844992-1	ASSEMBLY, STRIP GUIDE	29
-	-	1	1	1	1320928-6	STRIP GUIDE	24
-	-	1	1	1	2168083-2	SCR, SKT HD CAP, RoHS, M4 X 8.0	21
-	-	1	1	1	1-18028-2	WASHER, FLAT, REG M4	20
-	-	1	1	1	2119533-1	STRIPPER, SIDE FEED	19
-	-	1	1	1	2119806-1	INSERT, SHEAR	13
-	-	1	1	1	3-22280-3	SPRING, COMPRESSION	12
-	-	1	1	1	1-356885-4	STOP, SHEAR	11
-	-	1	1	1	2119805-1	SHEAR HOLDER, FRONT	10
-	-	1	1	1	1803095-1	FLOATING SHEAR, FRONT	9
1	1	2	2	1	2-1803293-3	ANVIL, COMBINATION DEUTSCH STYLE	8
-	-	1	1	1	3-240641-7	SPACER	7
-	-	-	-	-	-	-	6
-	-	1	1	1	1-2119757-3	DEPRESSOR, SHEAR	5
-	-	1	1	1	238011-2	BLOCK, CRIMPER SPACER	4
1	1	2	2	1	2-1803019-9	CRIMPER, INSULATION O	3
-	-	1	1	1	455888-4	SPACER, CRIMPER	2
-	-	2	2	1	4-1633713-7	CRIMPER, WIRE PREMIUM	1

ATLANTIC VERSION
Shown on sheets 1 of 4 & 2 of 4
(Pacific version shown on sheets 3 of 4 & 4 of 4)

DIMENSIONS: mm 	TOLERANCES UNLESS OTHERWISE SPECIFIED: 0 PLC ± 1 PLC ± 2 PLC ± 3 PLC ± 4 PLC ± ANGLES ±	DWG: R. KNEPPER 22-Jan-14 CHK: G. BAILEY 22-Jan-14 APVD: M. CLIFFORD 22-Jan-14 PRODUCT SPEC: APPLICATION SPEC: MATERIAL: FINISH:	NAME: Ocean Side Feed Applicator SIZE: A1 CAGE CODE: 00779 DRAWING NO: C=2266127 RESTRICTED TO: Customer Accessible Production Drawing SCALE: 1:2 SHEET: 1 of 4 REV: C
-----------------------	---	--	---

LOC		DIST		REVISIONS			
A	66	P	LTM	DESCRIPTION	DATE	OWN	APVD
		-		SEE SHEET 1			

FEED TYPE MECHANICAL

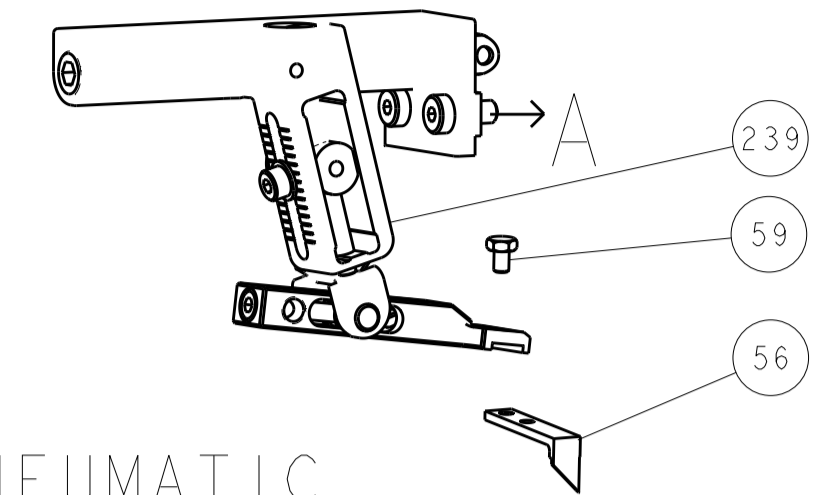

PNEUMATIC

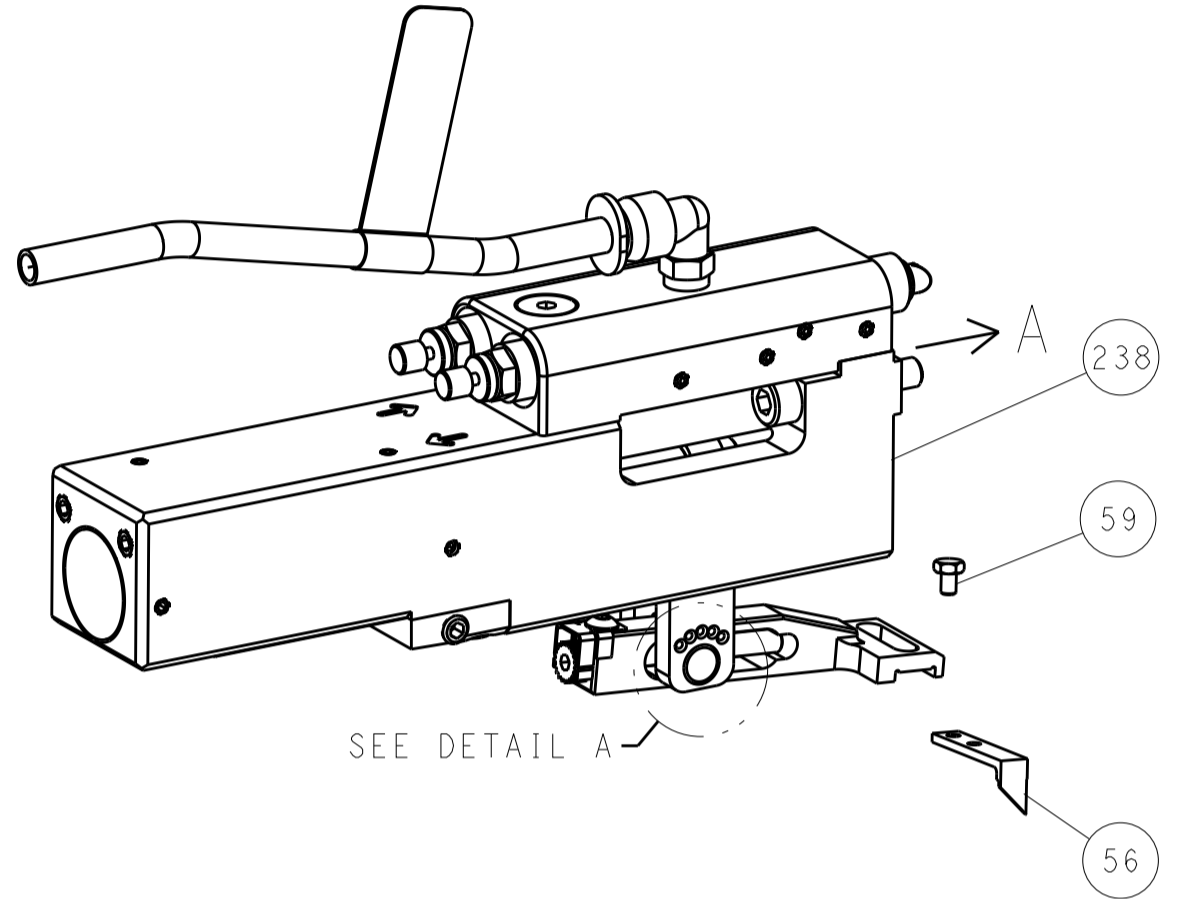

FEED SPRING SETTING POSITION (SHOWN FROM REAR SIDE)

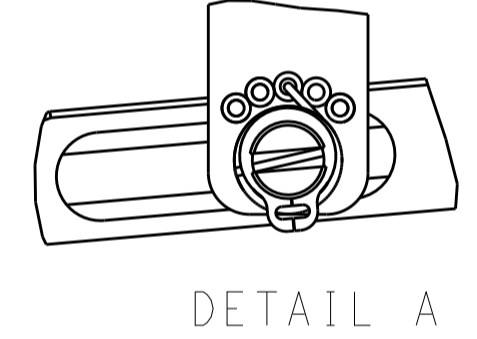

DETAIL A

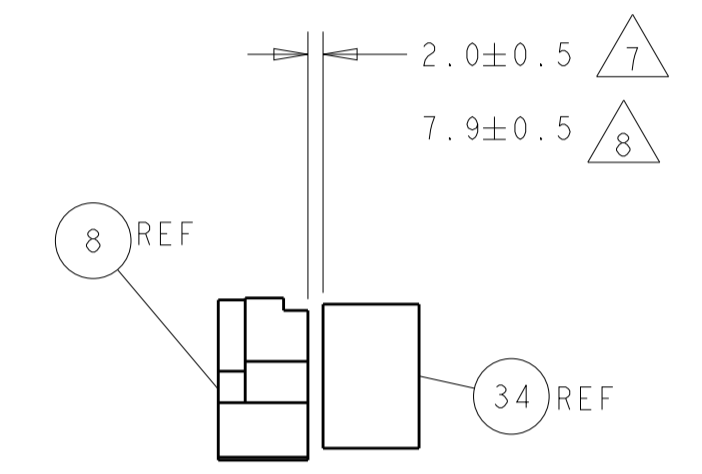
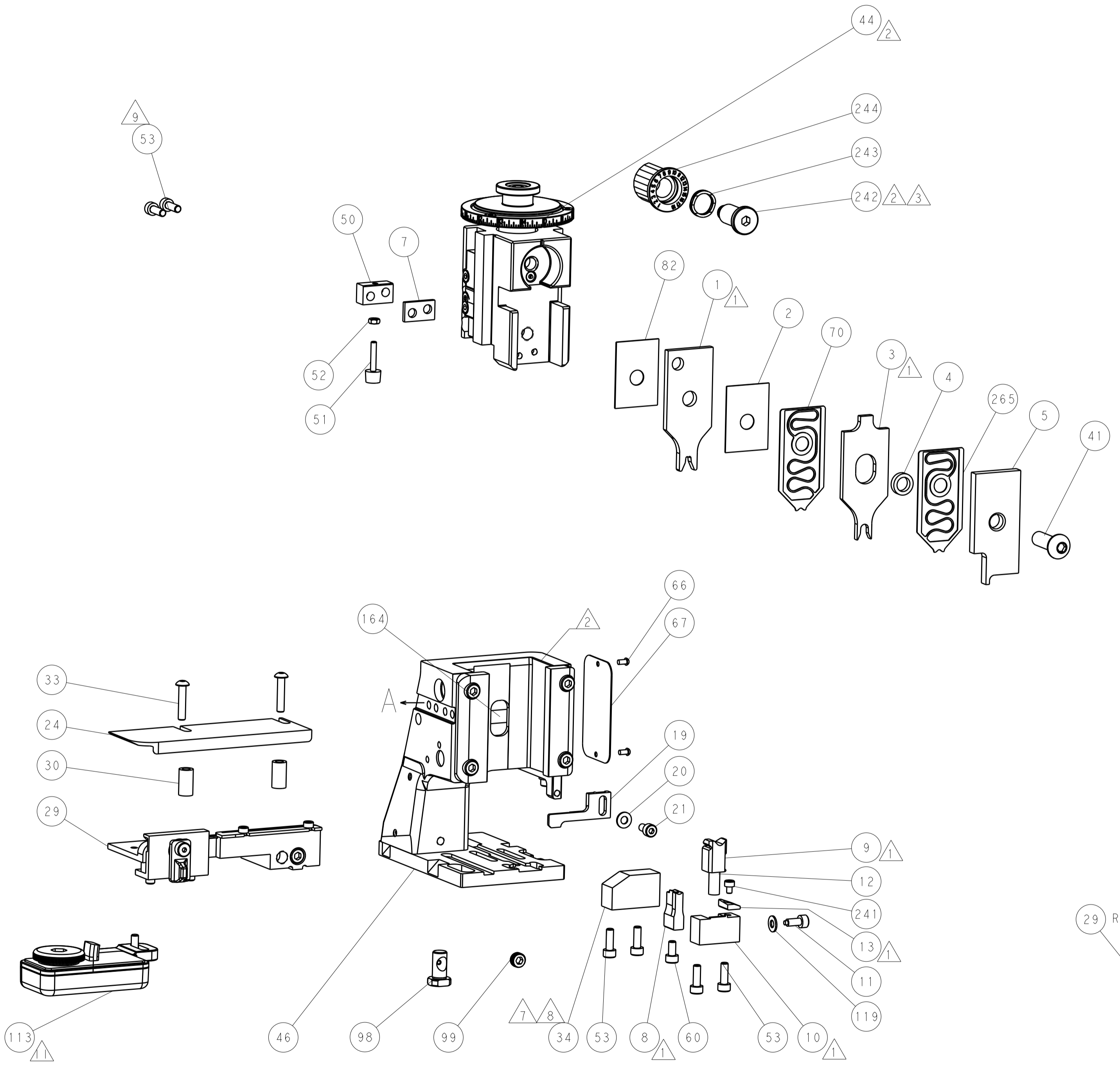

TERMINAL SUPPORT LOCATION

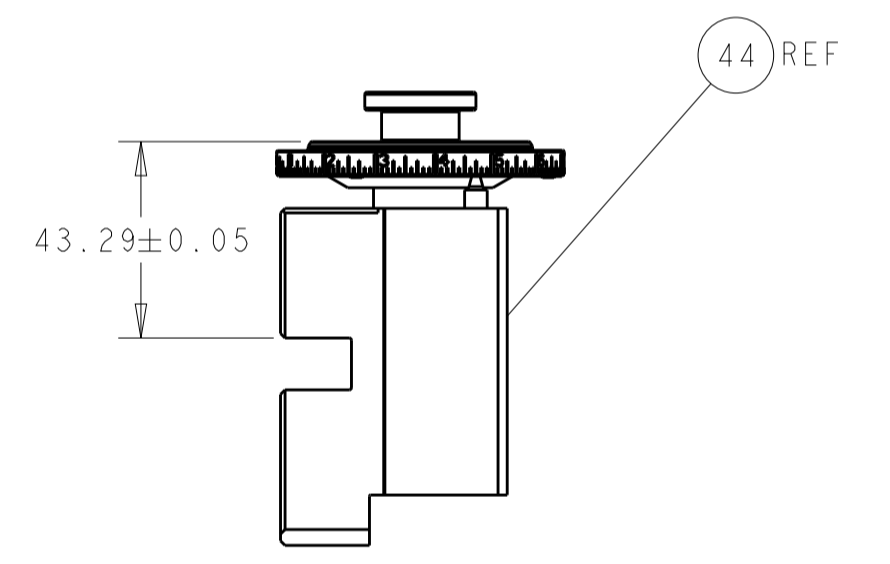

HOLDDOWN SET-UP

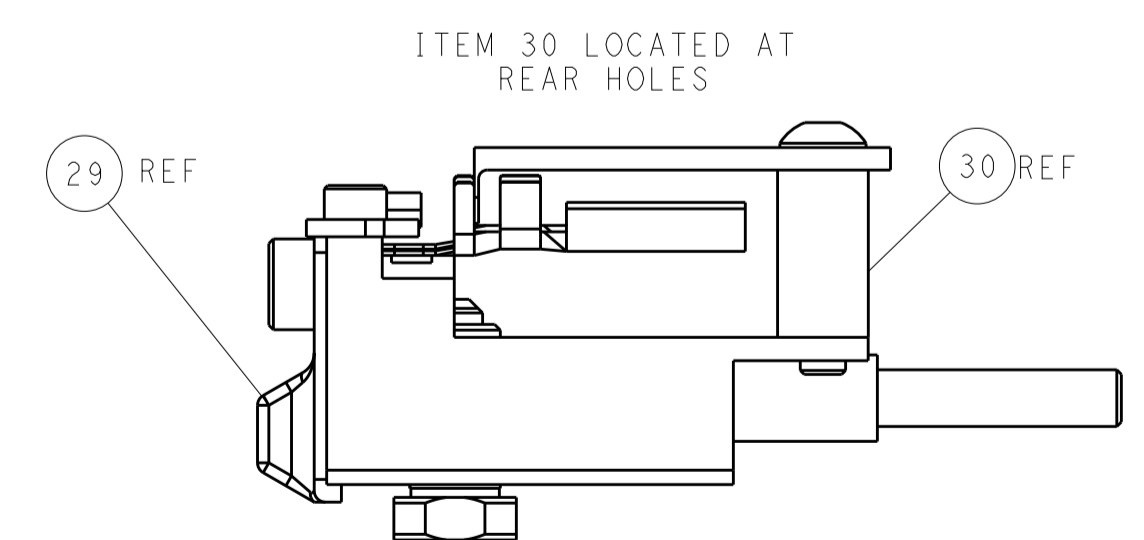

ITEM 30 LOCATED AT REAR HOLES

CAM POSITIONS

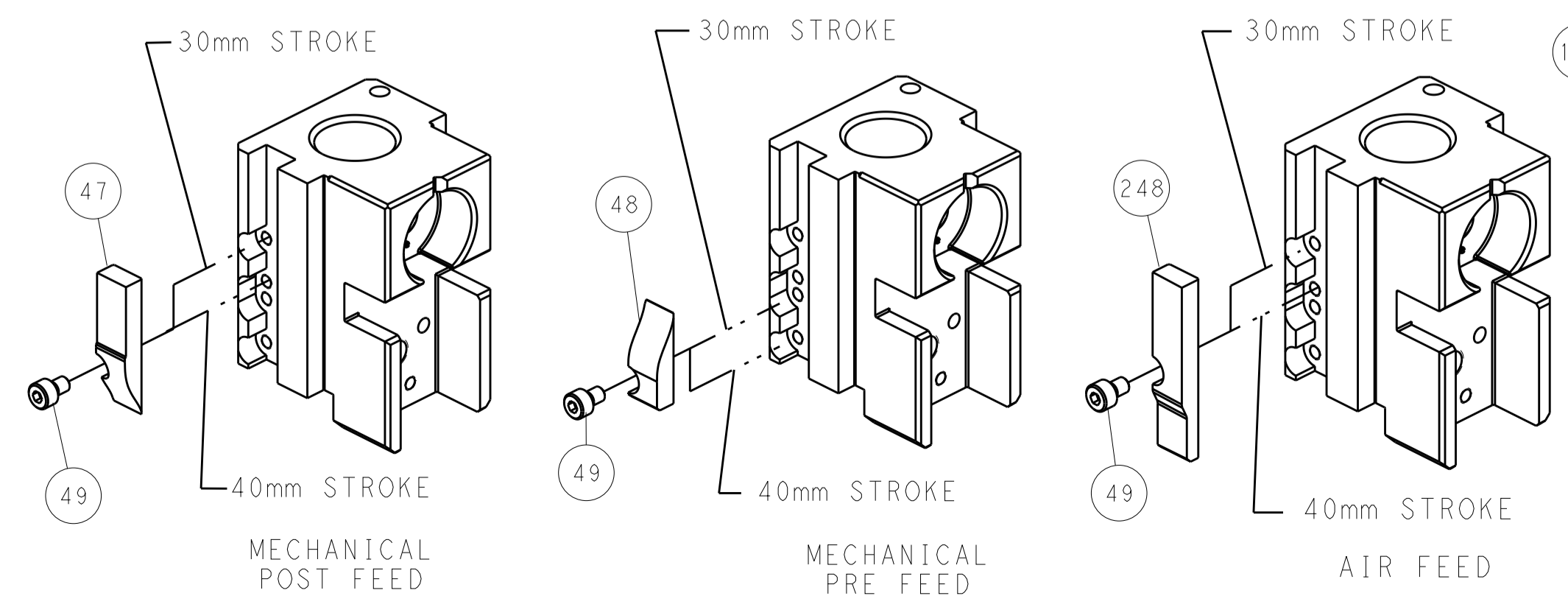

ATLANTIC VERSION
 Shown on sheets 1 of 4 & 2 of 4
 (Pacific version shown on sheets 3 of 4 & 4 of 4)

DIMENSIONS:		TOLERANCES UNLESS OTHERWISE SPECIFIED:		DWN R. KNEPPER 22-Jan-14 CHK G. BAILEY 22-Jan-14 APVD M. CLIFFORD 22-Jan-14 NAME: Ocean Side Feed Applicator	
mm	0 PLC ±	1 PLC ±	2 PLC ±	3 PLC ±	4 PLC ±
ANGLES	FINISH	WEIGHT	SCALE	SHEET	REV
			1:2	2 of 4	C

PART NUMBER	REVISION	DESCRIPTION	FEED TYPE
2-2266127-1	C	FINE CRIMP HEIGHT ADJUST	MECHANICAL
2-2266127-2	C	FINE CRIMP HEIGHT ADJUST	PNEUMATIC
7-2266127-7	B	CRIMP TOOLING KIT	-
7-2266127-8	B	APPLICATOR CONVERSION KIT	-

PACIFIC VERSION TERMINATOR
INTERFACE ADAPTER

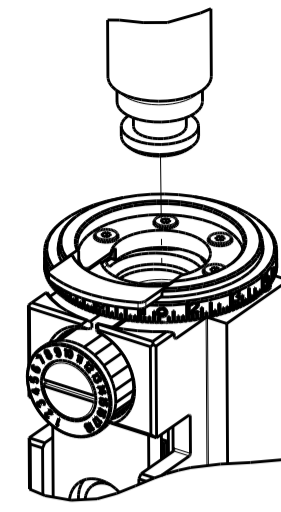

APPLICATOR DATA		
CRIMP	SIZE	TYPE
WIRE	3.28 mm [.129]	F
INSUL	4.83 mm [.190]	O
APPLICATOR INSTRUCTIONS 408-35042		

APPLICATOR CONVERSION KITS	
PART NUMBER	INSULATION DIAMETER RANGE
7-2266127-8	Ø 4.65-5.18 mm [.183-.204]
7-2266128-8	Ø 3.96-4.62 mm [.156-.182]
7-2266129-8	Ø 3.56-3.94 mm [.140-.155]

TERMINAL DATA: DEUTSCH TERMINAL TE CRIMP SPECIFICATION			
TERMINAL NAME: STAMPED CONTACT PIN SIZE 12			
WIRE STRIP LENGTH		INSULATION DIAMETER RANGE	
5.71-6.99 mm [.225-.275 IN]		Ø 4.65-5.18 mm [.183-.204 IN]	
TERMINAL APPLICATION SPECIFICATION	114-151006	-	-
TERMINALS APPLIED			
TE TERMINAL	DEUTSCH TERMINAL	TE TERMINAL	DEUTSCH TERMINAL
286989-1	1060-12-0222	286989-2	1060-12-0244

TERMINAL DATA: DEUTSCH TERMINAL TE CRIMP SPECIFICATION			
TERMINAL NAME: STAMPED CONTACT SOCKET SIZE 12			
WIRE STRIP LENGTH		INSULATION DIAMETER RANGE	
5.71-6.99 mm [.225-.275 IN]		Ø 4.65-5.18 mm [.183-.204 IN]	
TERMINAL APPLICATION SPECIFICATION	114-151006	-	-
TERMINALS APPLIED			
TE TERMINAL	DEUTSCH TERMINAL	TE TERMINAL	DEUTSCH TERMINAL
286988-1	1062-12-0222	286988-2	1062-12-0244

WIRE SIZE	CRIMP HEIGHT mm [INCH]	CRIMP HEIGHT REFERENCE SETTING
6.00mm2	2.72+0.03/-0.05 [.107+.001/- .002]	5.4
10 AWG	2.51+0.03/-0.05 [.099+.001/- .002]	7.6
5.00mm2	2.51+0.03/-0.05 [.099+.001/- .002]	7.5
4.00mm2	2.16+0.03/-0.05 [.085+.001/- .002]	11.0

- RECOMMENDED SPARE PARTS
- REFER TO SUPPLIED INSTRUCTION SHEET FOR CLEANING, LUBRICATION AND STORAGE OF APPLICATOR.
- APPLY PART NUMBER 2-23419-6 LOCTITE TO THREADS OF ITEM 242.
- CRIMP HEIGHT REFERENCE SETTING WAS THE SETTING USED WHEN THE APPLICATOR WAS QUALIFIED AT THE FACTORY. ADJUSTMENT MAY BE NECESSARY WHEN RUNNING APPLICATOR IN THE FIELD.
- 5. UNLESS SPECIFIED OTHERWISE TORQUE VALUES SHALL BE USED PER DOCUMENT, 101-35000.
- WHEN ASSEMBLING A NON CRIMP HEIGHT ADJUST APPLICATOR (-6) USE SHIMS FROM ITEM 260 TO ACHIEVE A NOMINAL SHIM HEIGHT OF 3.08.
- DIMENSION 2.0±0.5 APPLIES TO PIN TERMINALS 1060-12-02XX.
- DIMENSION 7.9±0.5 APPLIES TO SOCKET TERMINALS 1062-12-02XX.
- CUT TO LENGTH AT ASSEMBLY.
- SEE APPROPRIATE APPLICATOR LOG SHEETS FOR APPLIED TERMINALS, WIRE RANGE AND MEMORY CHIP.
- TERMINAL LUBRICANT IS RECOMMENDED.

***WARNING**
ON INSTALLATION, SET WIRE DISC TO CRIMP HEIGHT REFERENCE SETTING FOR LARGEST WIRE SIZE. CRIMP HEIGHT REFERENCE SETTINGS GREATER THAN THE VALUE SHOWN MAY CAUSE DAMAGE TO THE CRIMP TOOLING, REFER TO THE INSTRUCTION SHEET FOR PROPER SETUP AND ADJUSTMENTS.

PACIFIC VERSION
Shown on sheets 3 of 4 & 4 of 4
(Atlantic version shown on sheets 1 of 4 & 2 of 4)

LOC	DIST	REV	DATE	BY	APPV
A	66				

REVISIONS						
REV	DATE	DESCRIPTION	DATE	BY	APPV	
-	-	SEE SHEET 1	-	-	-	
-	-	1	1	2119791-9	DEPRESSOR, WIRE	265
-	-	1	1	2119082-9	CAM, SNAIL, INSULATION ADJUSTMENT	244
-	-	1	1	2079764-1	WASHER, WAVE SPRING, CREST-TO-CREST	243
-	-	1	1	2119083-1	RETAINER, INSULATION DIAL	242
-	-	1	1	7-18023-7	SCR, SKT HD CAP M3 X 4.0	241
-	-	-	1	2119580-1	MECHANICAL FEED ASSEMBLY	239
-	-	1	-	2844940-1	AIR FEED MODULE	238
-	-	REF	REF	994970-2	COUNTER, MAGNETIC	164
-	-	1	-	2119641-2	FEED CAM, AIR FEED	151
-	-	1	1	2168083-8	SCR, SKT HD CAP, RoHS, M4 X 16	144
-	-	4	4	2168083-9	SCR, SKT HD CAP, RoHS, M4 X 20	143
-	-	-	1	2119653-2	FEED CAM, POST FEED	142
-	-	1	1	1-1803583-0	APPLICATOR BASIC ASSEMBLY, SF	141
-	-	1	1	1803516-1	RAM ASSEMBLY, SF PACIFIC	140
-	-	1	1	1-18028-2	WASHER, FLAT, REG M4	119
-	-	1	1	2119955-1	ASSY, LUBRICATOR, SIDE FEED	113
-	-	1	1	2844908-1	SCREW, LOCKING	99
-	-	1	1	2844907-1	POST, LOCKING	98
-	-	1	1	455888-5	SPACER, CRIMPER	82
1	-	-	-	2266127	PRINT, APPLICATOR LOG SHEET	72
-	-	1	1	1803607-3	DOCUMENTATION PACKAGE	71
-	-	1	1	2119791-9	DEPRESSOR, WIRE	70
-	-	1	1	2119740-1	TAG, IDENTIFICATION	67
-	-	2	2	2168078-1	SCREW, DRIVE, RH, RoHS, 2 x .188	66
-	-	1	1	5-18022-5	SCR, HEX HD CAP, M4 X 6.0	59
-	-	1	1	1338685-1	PAWL, FEED	56
-	-	2	2	2168083-3	SCR, SKT HD CAP, RoHS, M4 X 12.0	53
-	-	1	1	5018030-1	NUT, HEX, REG, RoHS, M3	52
-	-	1	1	811242-5	BUMPER, HOLD DOWN	51
-	-	1	1	690753-2	SPACER, TONKER	50
-	-	1	2	18023-9	SCR, SKT HD CAP M4 X 6.0	49
-	-	-	1	2119652-1	FEED CAM, PRE FEED	48
-	-	1	1	1803602-1	SCR, BHSC, RoHS (M8 X 25)	41
-	-	1	1	1752356-6	SUPPORT, TERMINAL	34
-	-	2	2	2079383-5	SCR, BHSC, RoHS (M4 X 20)	33
-	-	2	2	2-2844962-8	SPACER, CYLINDRICAL, STRIP GUIDE	30
-	-	1	1	2844992-1	ASSEMBLY, STRIP GUIDE	29
-	-	1	1	1320928-6	STRIP GUIDE	24
-	-	1	1	2168083-2	SCR, SKT HD CAP, RoHS, M4 X 8.0	21
-	-	1	1	1-18028-2	WASHER, FLAT, REG M4	20
-	-	1	1	2119533-1	STRIPPER, SIDE FEED	19
-	-	1	1	2119806-1	INSERT, SHEAR	13
-	-	1	1	3-22280-3	SPRING, COMPRESSION	12
-	-	1	1	1-356885-4	STOP, SHEAR	11
-	-	1	1	2119805-1	SHEAR HOLDER, FRONT	10
-	-	1	1	1803095-1	FLOATING SHEAR, FRONT	9
1	1	1	1	2-1803293-3	ANVIL, COMBINATION DEUTSCH STYLE	8
-	-	1	1	3-240641-7	SPACER	7
-	-	-	-	-	-	6
-	-	1	1	1-2119757-3	DEPRESSOR, SHEAR	5
-	-	1	1	238011-2	BLOCK, CRIMPER SPACER	4
1	1	1	1	2-1803019-9	CRIMPER, INSULATION O	3
-	-	1	1	455888-4	SPACER, CRIMPER	2
-	-	1	1	4-1633713-7	CRIMPER, WIRE PREMIUM	1
-78	-77	-22	-21	PART NO	DESCRIPTION	ITEM NO

DIMENSIONS:		TOLERANCES UNLESS OTHERWISE SPECIFIED:		OWN	22-Jan-14	TE Connectivity Harrisburg, PA 17105-3608
mm	0 PLC ±	1 PLC ±	2 PLC ±	CHK	22-Jan-14	
MATERIAL:		FINISH:		APV	22-Jan-14	NAME
				WGT		Ocean Side Feed Applicator
				SCALE	1:2	RESTRICTED TO
				SHEET	3 OF 4	REV
				CAGE CODE	00779	
				DRAWING NO	C=2266127	
				Customer Accessible Production Drawing		

LOC		DIST		REVISIONS				
P	LTN	DATE	DMN	APVD	DESCRIPTION	DATE	DMN	APVD
-	-	SEE SHEET 1	-	-				

FEED TYPE MECHANICAL

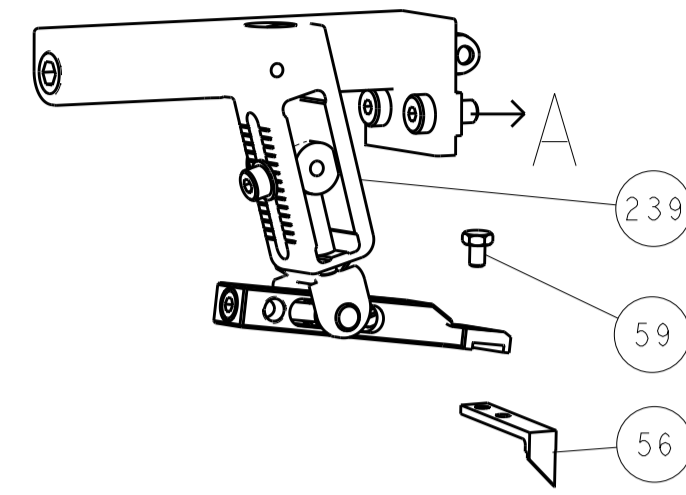

PNEUMATIC

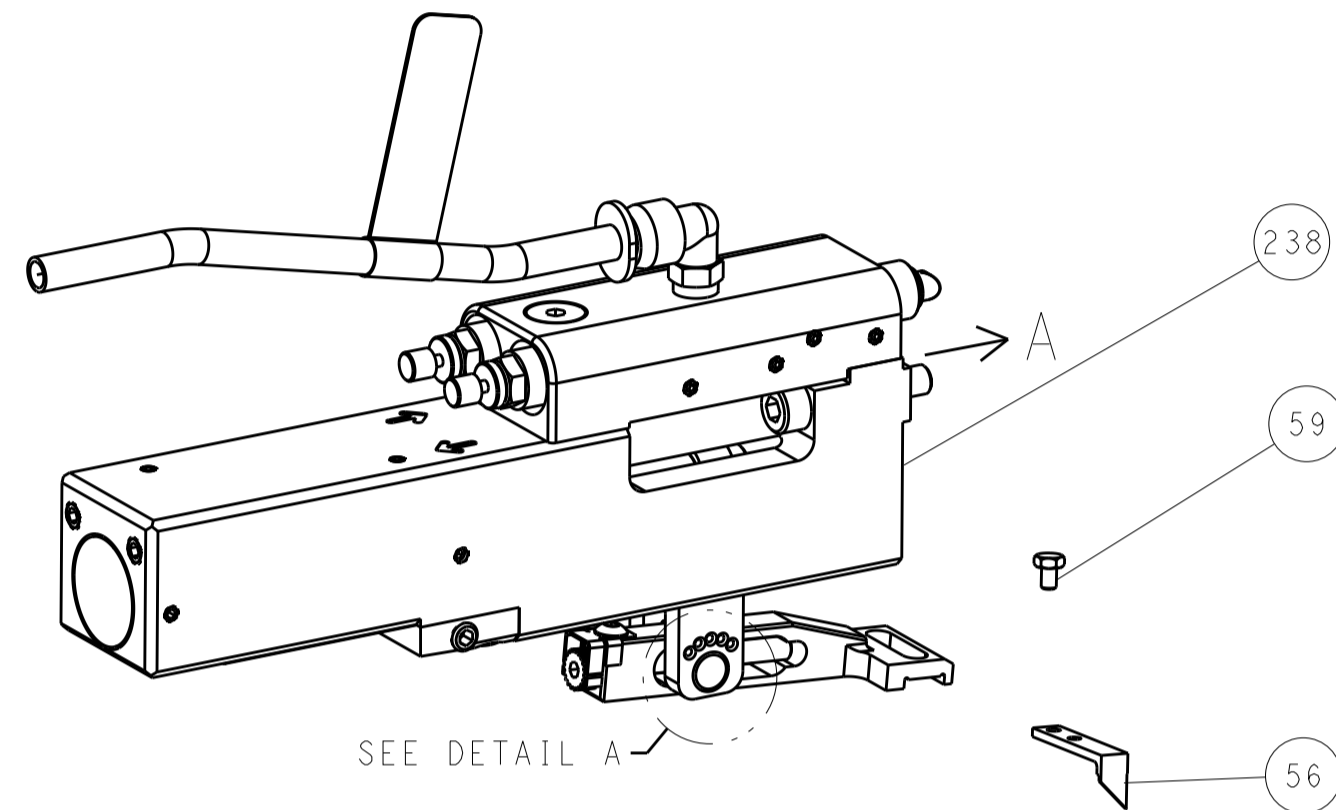

FEED SPRING SETTING POSITION (SHOWN FROM REAR SIDE)

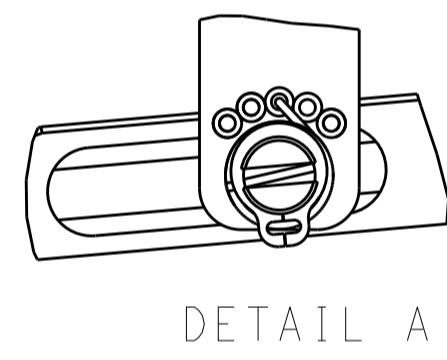

CAM POSITIONS

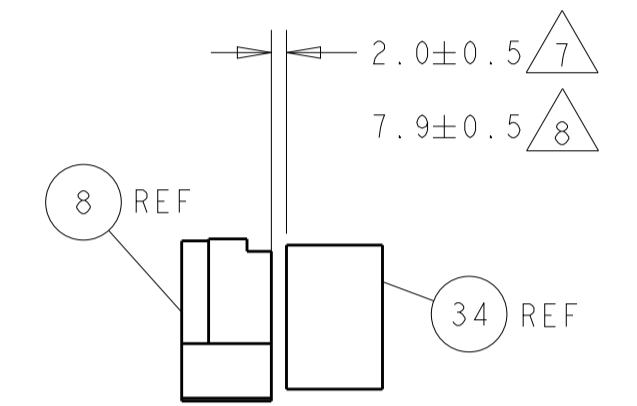
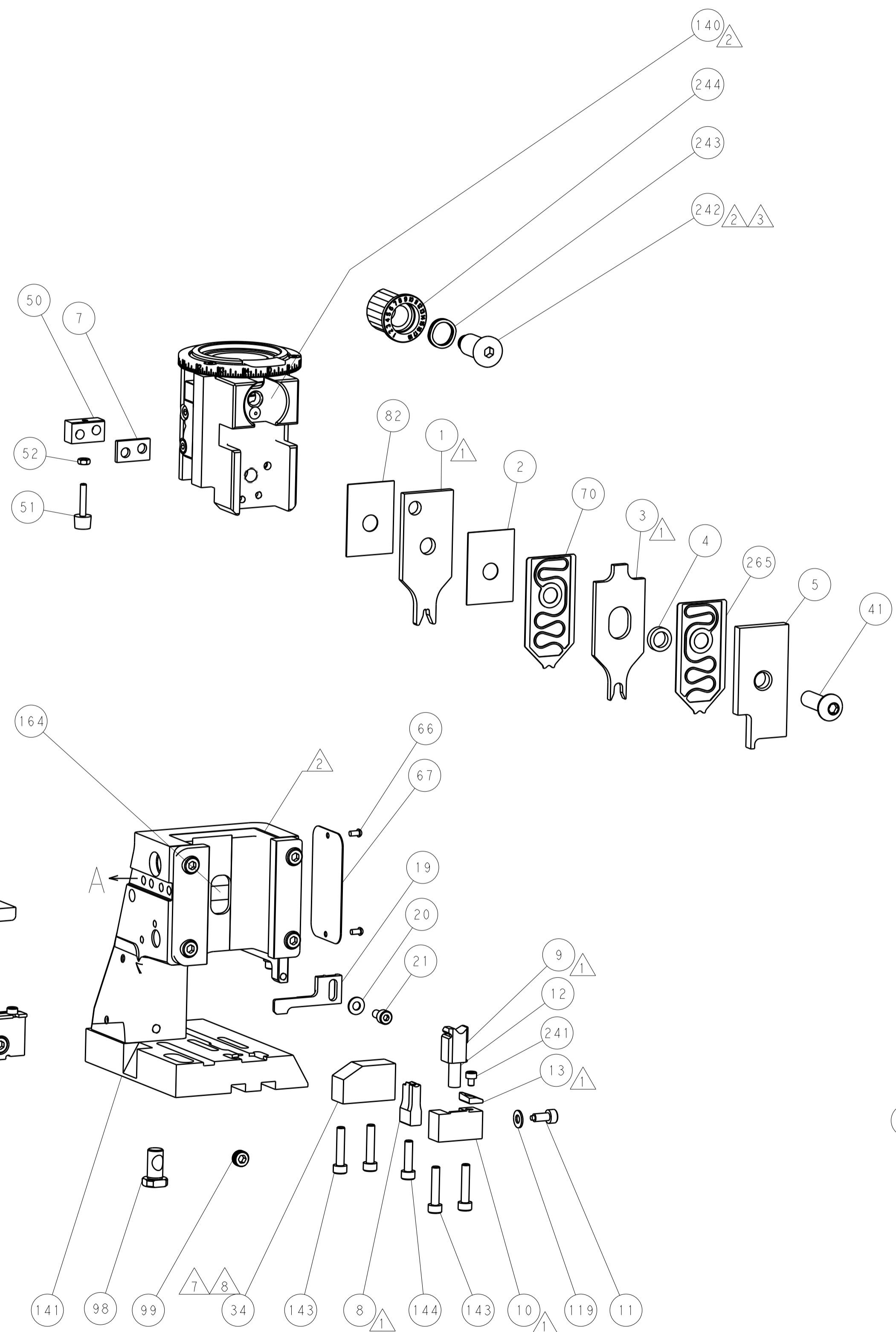
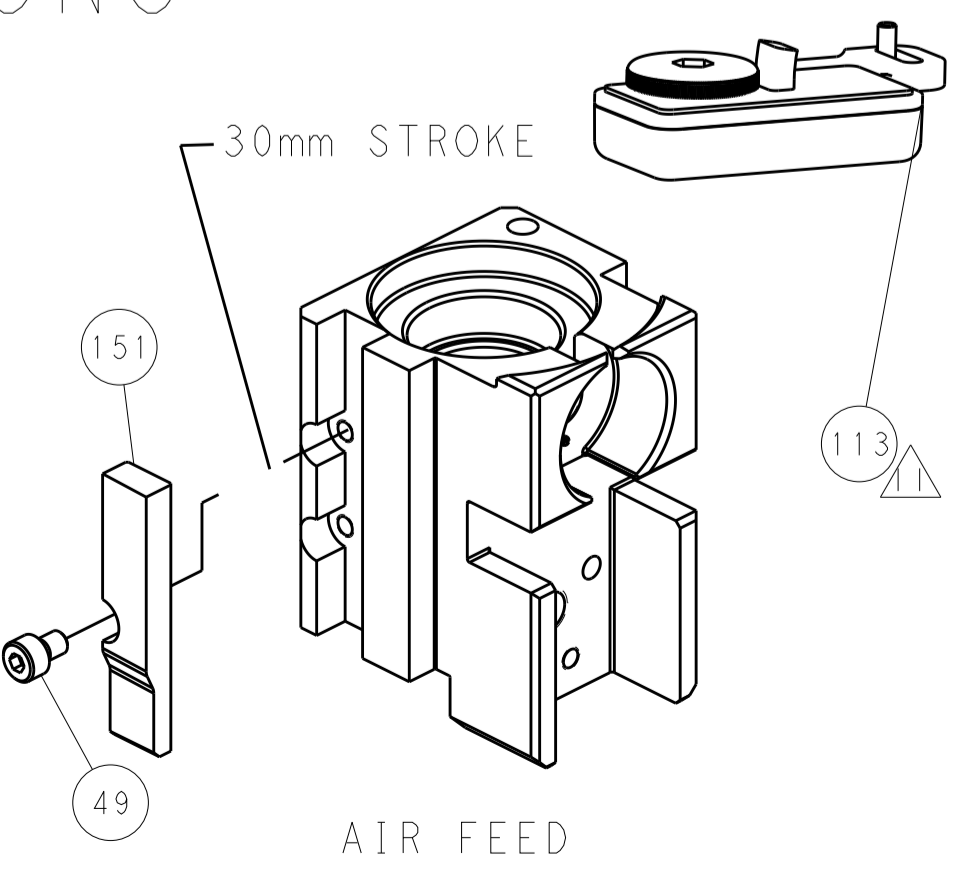
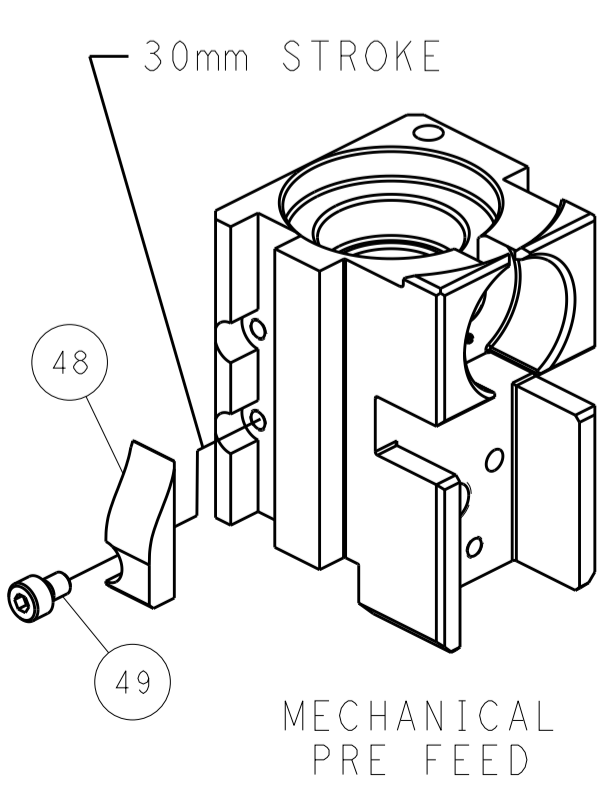
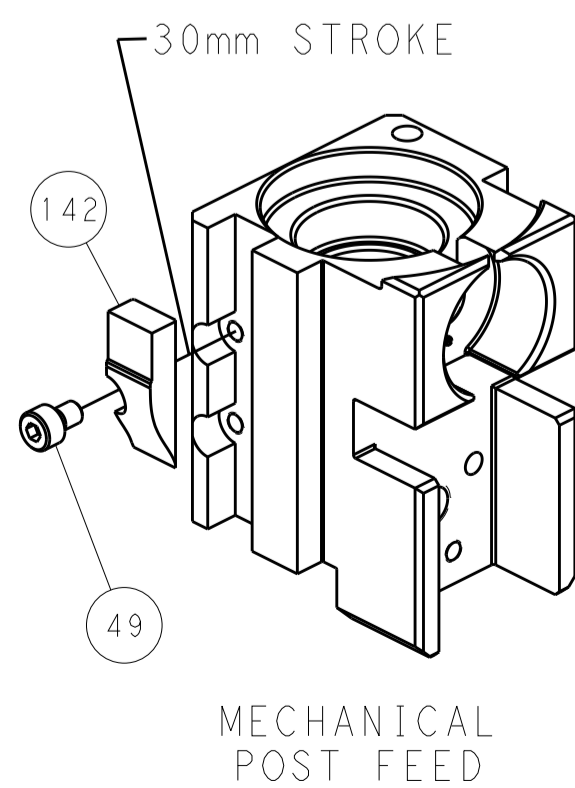

TERMINAL SUPPORT LOCATION

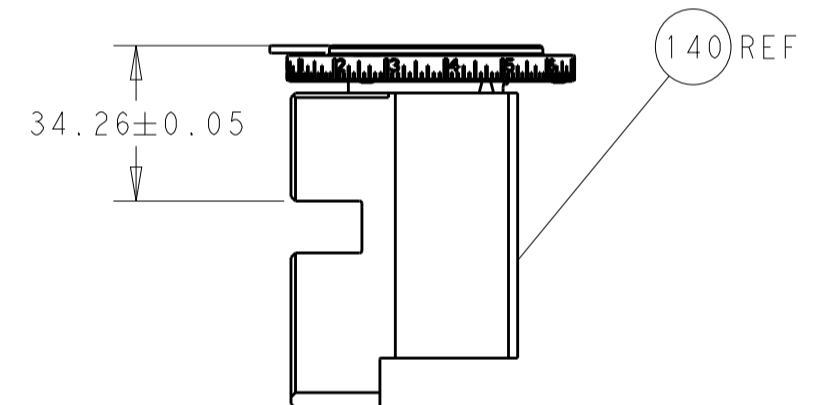

HOLDDOWN SET-UP

ITEM 30 LOCATED AT REAR HOLES

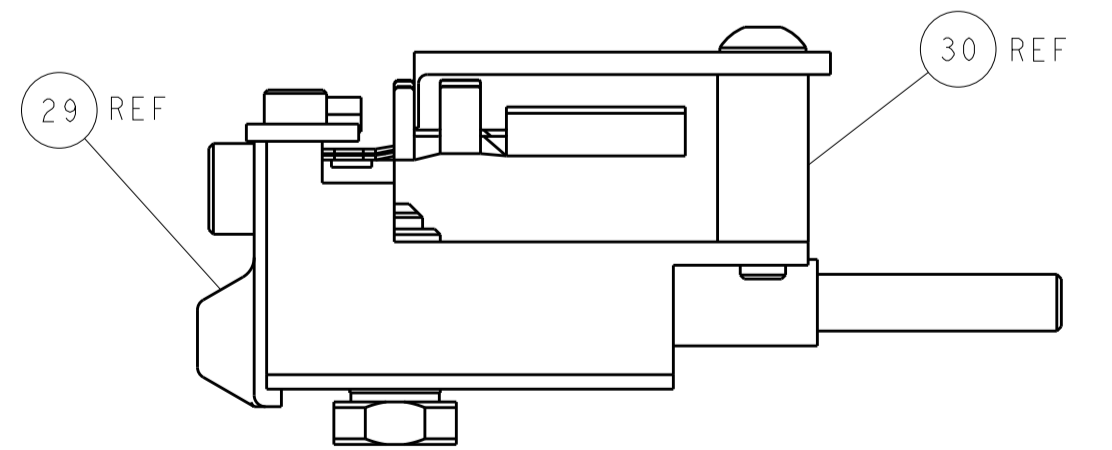

FEED TRACK POSITION GUIDE BY INSULATION BARREL

PACIFIC VERSION
 Shown on sheets 3 of 4 & 4 of 4
 (Atlantic version shown on sheets 1 of 4 & 2 of 4)

DIMENSIONS:		TOLERANCES UNLESS OTHERWISE SPECIFIED:		DWG: R. KNEPPER 22-Jan-14		TE Connectivity	
mm	0 PLC ±	1 PLC ±	2 PLC ±	3 PLC ±	4 PLC ±	5 PLC ±	Harrisburg, PA 17105-3608
	ANGLES	FINISH		CHK: G. BAILEY 22-Jan-14	NAME: Ocean Side Feed Applicator	SIZE: A1	RESTRICTED TO
MATERIAL:				APVD: M. CLIFFORD 22-Jan-14	PRODUCT SPEC:	CAGE CODE: 00779	DRAWING NO: 2266127
				WEIGHT:	APPLICATION SPEC:	SCALE: 1:2	SHEET 4 OF 4
				Customer Accessible Production Drawing		REV C	