

| LOC | DIST | REVISIONS |     |                           |         |     |      |
|-----|------|-----------|-----|---------------------------|---------|-----|------|
| AF  | 50   | P         | LTR | DESCRIPTION               | DATE    | DWN | APVD |
|     |      | J         |     | REVISED PER ECR-06-010423 | 21SEP06 | HMR | KR   |

- 1 CONTINUOUS STRIP ON REELS WITH TERMINALS LOCATED ON  $8.38 \pm 0.08$  [ $.330 \pm .003$ ] CENTERS
- 2 SLOT ACCEPTS 0.57-0.81mm [#23-#20] AWG COPPER MAGNET WIRE. TWO WIRES OF THE SAME SIZE MAX PER SLOT FOR #23 GAGE. ONE WIRE MAX PER SLOT FOR #22-#20 AWG
- 3 IDENTIFICATION NUMBER 15 FOR THE MAGNET WIRE SLOT SIZE
- 4 0.25[.010] MAX CARRIER CUT-OFF TABS

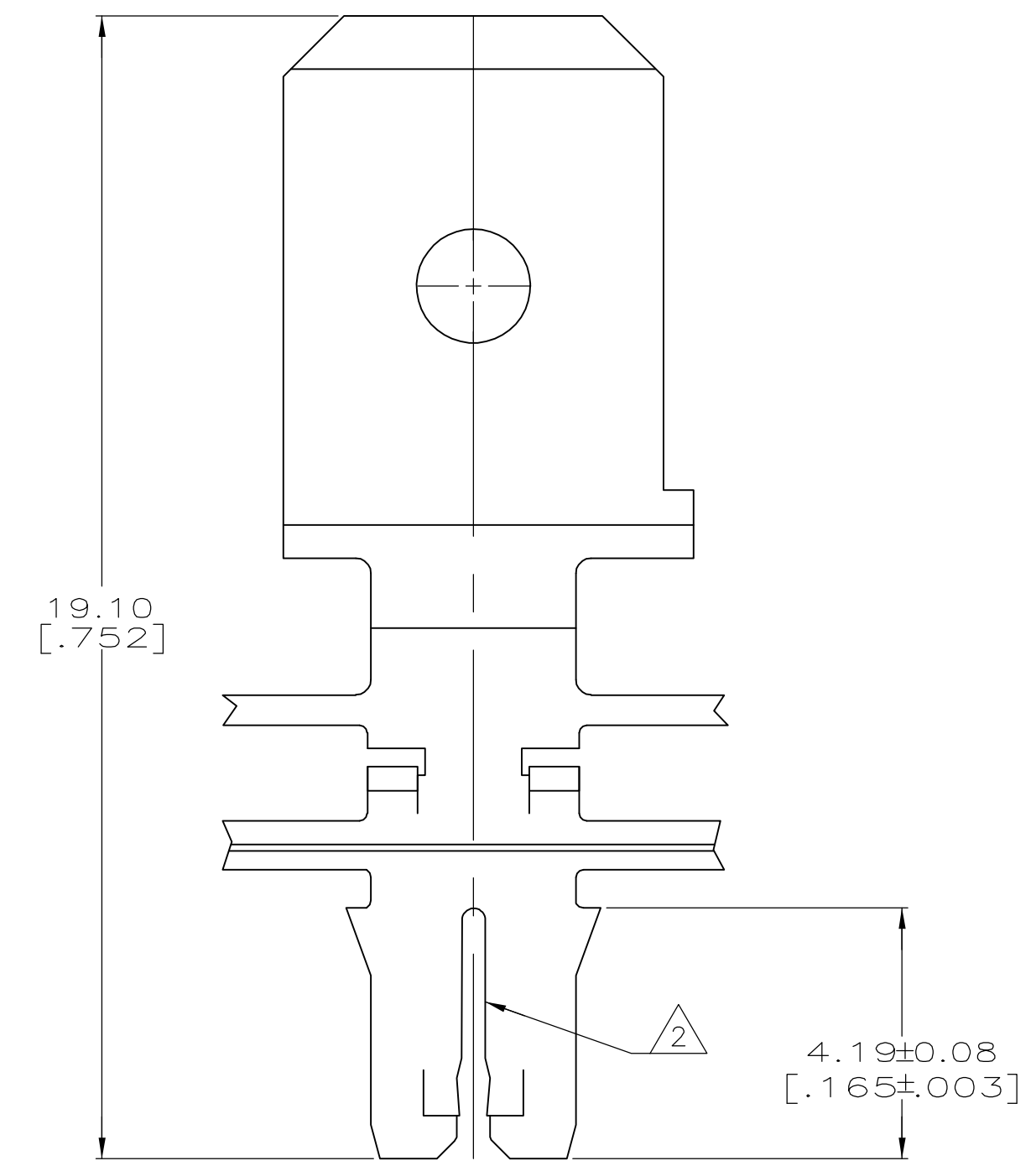
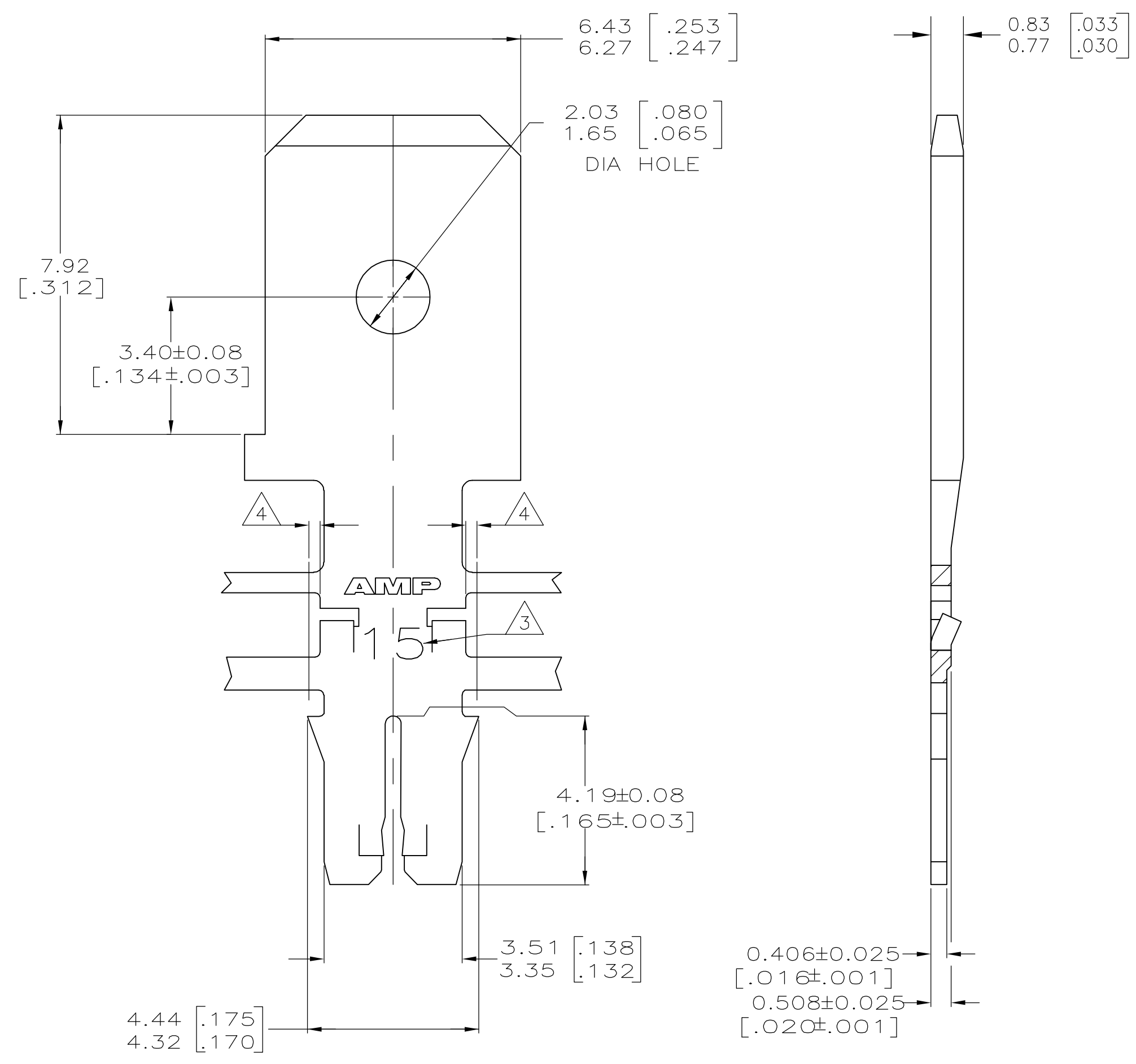

|          |                      |         |
|----------|----------------------|---------|
| OBSOLETE | 082 PRE-MILLED BRASS | 63719-2 |
|          | 4M PRE-MILLED BRASS  | 63719-1 |
|          | MATERIAL             | PART NO |

|  |   |                         |   |
|--|---|-------------------------|---|
| THIS DRAWING IS A CONTROLLED DOCUMENT. |   | DWN L.A.MAYER 9-27-93   | Tyco Electronics Corporation<br>Harrisburg, PA 17105-3608 |
| DIMENSIONS: mm [INCHES]                |   | CHK M.S. FEHER 9-27-93  |   |
| TOLERANCES UNLESS OTHERWISE SPECIFIED: |   | APVD A.HUNT III 9-27-93 | NAME  |
| 0 PLC ± -                              | 1 PLC ± -                               | PRODUCT SPEC            | TAB, 6.35 [.250] FASTON™                                  |
| 2 PLC ± 0.13 [.005]                    | 3 PLC ± -                               | APPLICATION SPEC        | MAG-MATE™ Slim Line                                       |
| 4 PLC ± -                              | ANGLES ± 1°                             | 114-2140                | SIZE CAGE CODE DRAWING NO                                 |
| MATERIAL SEE TABLE                     | FINISH 0.002032 [.000080] MIN TIN PLATE | WEIGHT -                | A2 00779 G-63719  |
|  |   | CUSTOMER DRAWING        | RESTRICTED TO -   |
|  |   | SCALE 10:1              | SHEET 1 of 1  |
|  |   |                         | REV J   |