

General Description

The ICS844004I-104 is a 4 output LVDS Synthesizer optimized to generate Fibre Channel reference clock frequencies. Using a 26.5625MHz 18pF parallel resonant crystal, the following frequencies can be generated based on the two frequency select pins (F_SEL[1:0]): 212.5MHz, 187.5MHz, 159.375MHz, 106.25MHz and 53.125MHz. The ICS844004I-104 uses IDT's 3RD generation low phase noise VCO technology and can achieve <1ps typical rms phase jitter, easily meeting Fibre Channel jitter requirements. The ICS844004I-104 is packaged in a 32-pin VFQFN package.

Features

- Four differential LVDS outputs
- Selectable crystal oscillator interface or LVCMOS/LVTTL single-ended input
- Supports the following output frequencies: 212.5MHz, 187.5MHz, 159.375MHz, 106.25MHz and 53.125MHz
- VCO range: 560MHz - 680MHz
- RMS phase jitter at 212.5MHz (637kHz – 10MHz), using a 26.5625MHz crystal: <1ps (typical)
- Full 3.3V or 2.5V output supply modes
- -40°C to 85°C ambient operating temperature
- Available in both standard (RoHS 5) and lead-free (RoHS 6) packages

Frequency Table

Input Frequency (MHz)	Inputs					Output Frequency (MHz)
	F_SEL1	F_SEL0	M Divider Value	N Divider Value	M/N Divider Value	
26.5625	0	0	24	3	8	212.5 (default)
26.5625	0	1	24	4	6	159.375
26.5625	1	0	24	6	4	106.25
26.5625	1	1	24	12	2	53.125
23.4375	0	0	24	3	8	187.5 (default)

Pin Assignment

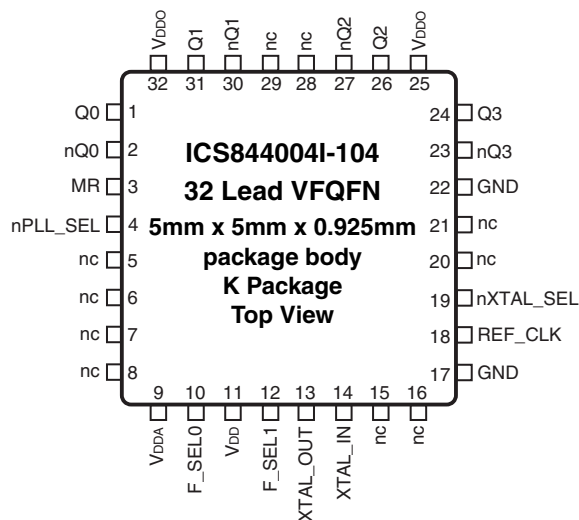

Block Diagram

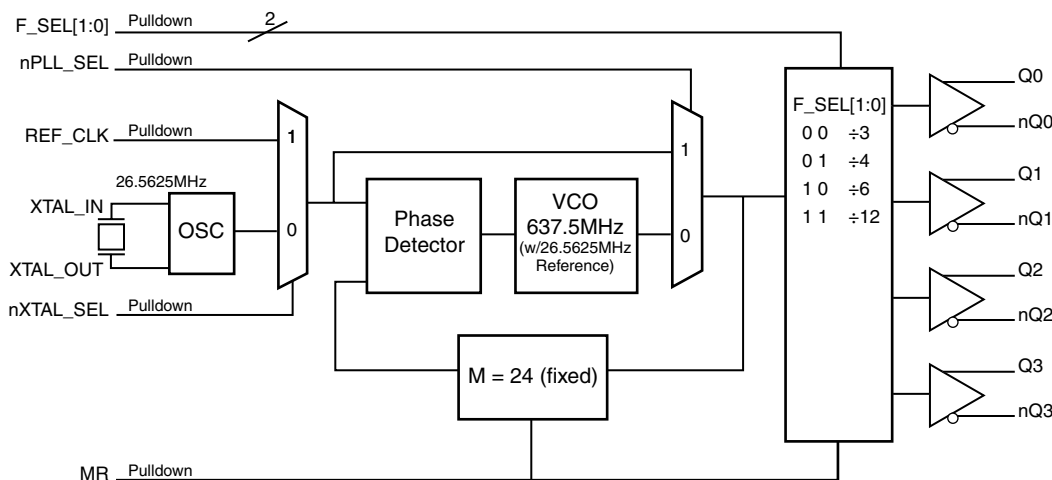

Table 1. Pin Descriptions

Number	Name	Type		Description
1, 2	Q0, nQ0	Output		Differential output pair. LVDS interface levels.
3	MR	Input	Pulldown	Active HIGH Master Reset. When logic HIGH, the internal dividers are reset causing the true outputs Qx to go low and the inverted outputs nQx to go high. When logic LOW, the internal dividers and the outputs are enabled. LVCMOS/LVTTL interface levels.
4	nPLL_SEL	Input	Pulldown	Selects between the PLL and REF_CLK as input to the dividers. When LOW, selects PLL (PLL Enable). When HIGH, deselects the reference clock (PLL Bypass). LVCMOS/LVTTL interface levels.
5, 6, 7, 8, 15, 16, 20, 21, 28, 29	nc	Unused		No connect.
9	V _{DDA}	Power		Analog supply pin.
10, 12	F_SEL0, F_SEL1	Input	Pulldown	Frequency select pin. LVCMOS/LVTTL interface levels.
11	V _{DD}	Power		Core supply pin.
13, 14	XTAL_OUT XTAL_IN	Input		Crystal oscillator interface. XTAL_IN is the input, XTAL_OUT is the output.
17, 22	GND	Power		Power supply ground.
18	REF_CLK	Input	Pulldown	Single-ended reference clock input. LVCMOS/LVTTL interface levels.
19	nXTAL_SEL	Input	Pulldown	Selects between crystal or REF_CLK inputs as the PLL Reference source. Selects XTAL inputs when LOW. Selects REF_CLK when HIGH. LVCMOS/LVTTL interface levels.
23, 24	nQ3, Q3	Output		Differential output pair. LVDS interface levels.
25, 32	V _{DDO}	Power		Output supply pins.
26, 27	Q2, nQ2	Output		Differential output pair. LVDS interface levels.
30, 31	nQ1, Q1	Output		Differential output pair. LVDS interface levels.

NOTE: *Pulldown* refers to internal input resistors. See Table 2, *Pin Characteristics*, for typical values.

Table 2. Pin Characteristics

Symbol	Parameter	Test Conditions	Minimum	Typical	Maximum	Units
C _{IN}	Input Capacitance			4		pF
R _{PULLDOWN}	Input Pulldown Resistor			51		kΩ

Absolute Maximum Ratings

NOTE: Stresses beyond those listed under *Absolute Maximum Ratings* may cause permanent damage to the device. These ratings are stress specifications only. Functional operation of product at these conditions or any conditions beyond those listed in the *DC Characteristics* or *AC Characteristics* is not implied. Exposure to absolute maximum rating conditions for extended periods may affect product reliability.

Item	Rating
Supply Voltage, V_{DD}	4.6V
Inputs, V_I	-0.5V to $V_{DD} + 0.5V$
Outputs, I_O Continuous Current Surge Current	10mA 15mA
Package Thermal Impedance, θ_{JA}	42.4°C/W (0 mps)
Storage Temperature, T_{STG}	-65°C to 150°C

DC Electrical Characteristics

Table 3A. Power Supply DC Characteristics, $V_{DD} = V_{DDO} = 3.3V \pm 5\%$, $T_A = -40^\circ C$ to $85^\circ C$

Symbol	Parameter	Test Conditions	Minimum	Typical	Maximum	Units
V_{DD}	Core Supply Voltage		3.135	3.3	3.465	V
V_{DDA}	Analog Supply Voltage		$V_{DD} - 0.12$	3.3	V_{DD}	V
V_{DDO}	Output Supply Voltage		3.135	3.3	3.465	V
I_{DD}	Power Supply Current				105	mA
I_{DDA}	Analog Supply Current				12	mA
I_{DDO}	Output Supply Current				120	mA

Table 3B. Power Supply DC Characteristics, $V_{DD} = V_{DDO} = 2.5V \pm 5\%$, $T_A = -40^\circ C$ to $85^\circ C$

Symbol	Parameter	Test Conditions	Minimum	Typical	Maximum	Units
V_{DD}	Core Supply Voltage		2.375	2.5	2.625	V
V_{DDA}	Analog Supply Voltage		$V_{DD} - 0.10$	2.5	V_{DD}	V
V_{DDO}	Output Supply Voltage		2.375	2.5	2.625	V
I_{DD}	Power Supply Current				100	mA
I_{DDA}	Analog Supply Current				10	mA
I_{DDO}	Output Supply Current				100	mA

Table 3C. LVCMOS/LVTTL DC Characteristics, $V_{DD} = V_{DDO} = 3.3V \pm 5\%$ or $2.5V \pm 5\%$, $T_A = -40^\circ\text{C}$ to 85°C

Symbol	Parameter	Test Conditions	Minimum	Typical	Maximum	Units
V_{IH}	Input High Voltage	$V_{DD} = 3.3V$	2		$V_{DD} + 0.3$	V
		$V_{DD} = 2.5V$	1.7		$V_{DD} + 0.3$	V
V_{IL}	Input Low Voltage	$V_{DD} = 3.3V$	-0.3		0.8	V
		$V_{DD} = 2.5V$	-0.3		0.7	
I_{IH}	Input High Current	REF_CLK, MR, F_SEL[0:1], nPLL_SEL, nXTAL_SEL	$V_{DD} = V_{IN} = 3.465V$ or $2.625V$		150	μA
I_{IL}	Input Low Current	REF_CLK, MR, F_SEL[0:1], nPLL_SEL, nXTAL_SEL	$V_{DD} = 3.465V$ or $2.625V$, $V_{IN} = 0V$			μA

Table 3D. LVDS DC Characteristics, $V_{DD} = V_{DDO} = 3.3V \pm 5\%$, $T_A = -40^\circ\text{C}$ to 85°C

Symbol	Parameter	Test Conditions	Minimum	Typical	Maximum	Units
V_{OD}	Differential Output Voltage		300	450	600	mV
ΔV_{OD}	V_{OD} Magnitude Change				50	mV
V_{OS}	Offset Voltage		1.2	1.425	1.65	V
ΔV_{OS}	V_{OS} Magnitude Change				50	mV

Table 3E. LVDS DC Characteristics, $V_{DD} = V_{DDO} = 2.5V \pm 5\%$, $T_A = -40^\circ\text{C}$ to 85°C

Symbol	Parameter	Test Conditions	Minimum	Typical	Maximum	Units
V_{OD}	Differential Output Voltage		250	400	550	mV
ΔV_{OD}	V_{OD} Magnitude Change				50	mV
V_{OS}	Offset Voltage		1.0	1.2	1.4	V
ΔV_{OS}	V_{OS} Magnitude Change				50	mV

Table 4. Crystal Characteristics

Parameter	Test Conditions	Minimum	Typical	Maximum	Units
Mode of Oscillation		Fundamental			
Frequency		23.33	26.5625	28.33	MHz
Equivalent Series Resistance (ESR)				50	Ω
Shunt Capacitance				7	pF

NOTE: Characterized using an 18pF parallel resonant crystal.

AC Electrical Characteristics

Table 5A. AC Characteristics, $V_{DD} = V_{DDO} = 3.3V \pm 5\%$, $T_A = -40^\circ\text{C}$ to 85°C

Symbol	Parameter	Test Conditions	Minimum	Typical	Maximum	Units
f_{OUT}	Output Frequency	$F_SEL[1:0] = 00$	186.67		226.66	MHz
		$F_SEL[1:0] = 01$	140		170	MHz
		$F_SEL[1:0] = 10$	93.33		113.33	MHz
		$F_SEL[1:0] = 11$	46.67		56.66	MHz
$t_{sk(o)}$	Output Skew; NOTE 1, 2			35	ps	
$f_{jit}(\emptyset)$	RMS Phase Jitter, Random; NOTE 3	212.5MHz, (637kHz - 10MHz)		0.73		ps
		159.375MHz, (637kHz - 10MHz)		0.78		ps
		106.25MHz, (637kHz - 10MHz)		0.92		ps
		53.125MHz, (637kHz - 10MHz)		0.95		ps
		187.5MHz, (637kHz - 10MHz)		0.75		ps
t_R / t_F	Output Rise/Fall Time	20% to 80%	250		500	ps
odc	Output Duty Cycle	$F_SEL[1:0] \neq \div 3$	48		52	%
		$F_SEL[1:0] = \div 3$	40		60	%

NOTE: Electrical parameters are guaranteed over the specified ambient operating temperature range, which is established when the device is mounted in a test socket with maintained transverse airflow greater than 500 lpm. The device will meet specifications after thermal equilibrium has been reached under these conditions.

NOTE 1: Defined as skew between outputs at the same supply voltages and with equal load conditions. Measured at the differential cross points.

NOTE 2: This parameter is defined in accordance with JEDEC Standard 65.

NOTE 3: Please refer to the Phase Noise Plots.

Table 5B. AC Characteristics, $V_{DD} = V_{DDO} = 2.5V \pm 5\%$, $T_A = -40^\circ\text{C}$ to 85°C

Symbol	Parameter	Test Conditions	Minimum	Typical	Maximum	Units
f_{OUT}	Output Frequency	$F_SEL[1:0] = 00$	186.67		226.66	MHz
		$F_SEL[1:0] = 01$	140		170	MHz
		$F_SEL[1:0] = 10$	93.33		113.33	MHz
		$F_SEL[1:0] = 11$	46.67		56.66	MHz
$t_{sk(o)}$	Output Skew; NOTE 1, 2			35	ps	
$f_{jit}(\emptyset)$	RMS Phase Jitter, Random; NOTE 3	212.5MHz, (637kHz - 10MHz)		0.72		ps
		159.375MHz, (637kHz - 10MHz)		0.88		ps
		106.25MHz, (637kHz - 10MHz)		0.89		ps
		53.125MHz, (637kHz - 10MHz)		0.96		ps
		187.5MHz, (637kHz - 10MHz)		0.74		ps
t_R / t_F	Output Rise/Fall Time	20% to 80%	250		550	ps
odc	Output Duty Cycle	$F_SEL[1:0] \neq \div 3$	48		52	%
		$F_SEL[1:0] = \div 3$	40		60	%

NOTE: Electrical parameters are guaranteed over the specified ambient operating temperature range, which is established when the device is mounted in a test socket with maintained transverse airflow greater than 500 lpm. The device will meet specifications after thermal equilibrium has been reached under these conditions.

NOTE 1: Defined as skew between outputs at the same supply voltages and with equal load conditions. Measured at the differential cross points.

NOTE 2: This parameter is defined in accordance with JEDEC Standard 65.

NOTE 3: Please refer to the Phase Noise Plots.

Typical Phase Noise at 106.25MHz (3.3V)

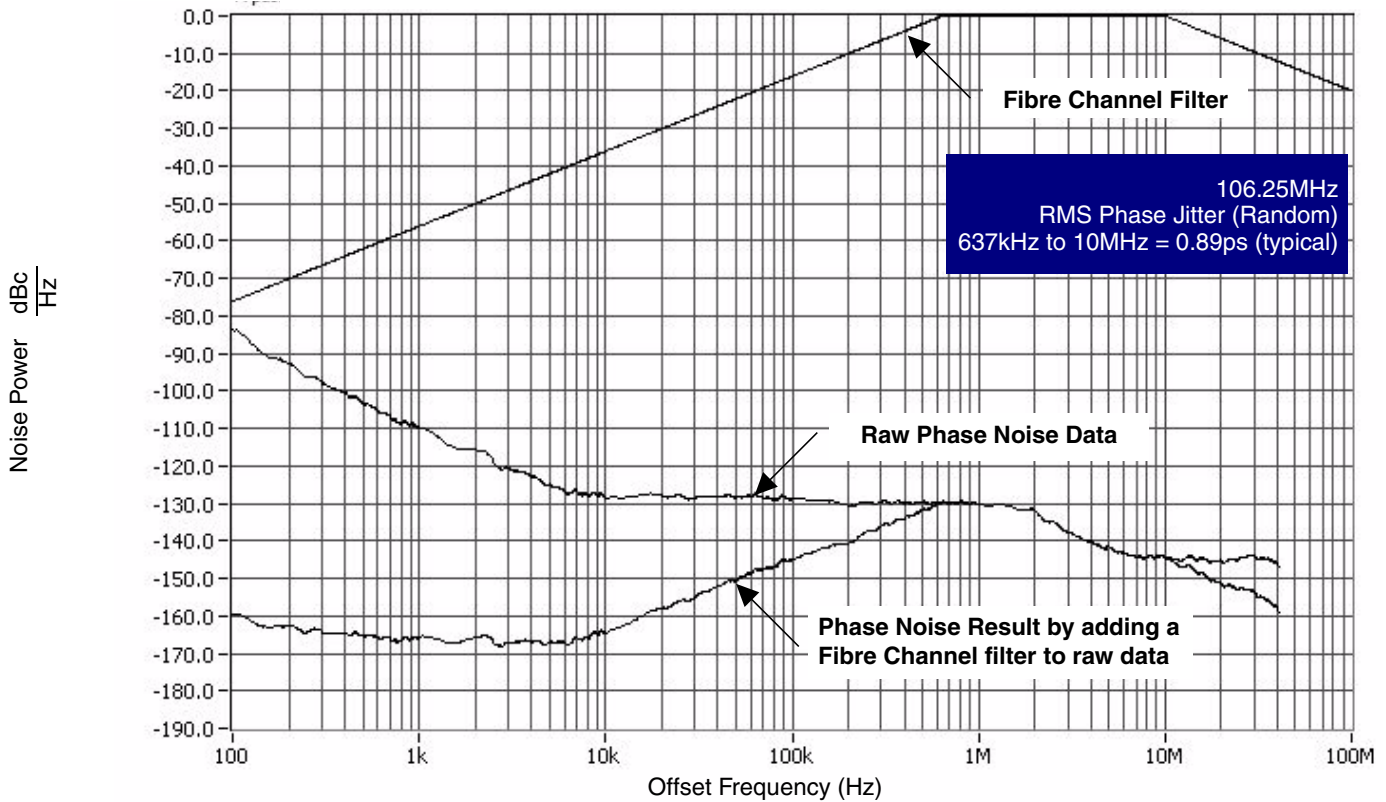

Typical Phase Noise at 212.5MHz (3.3V)

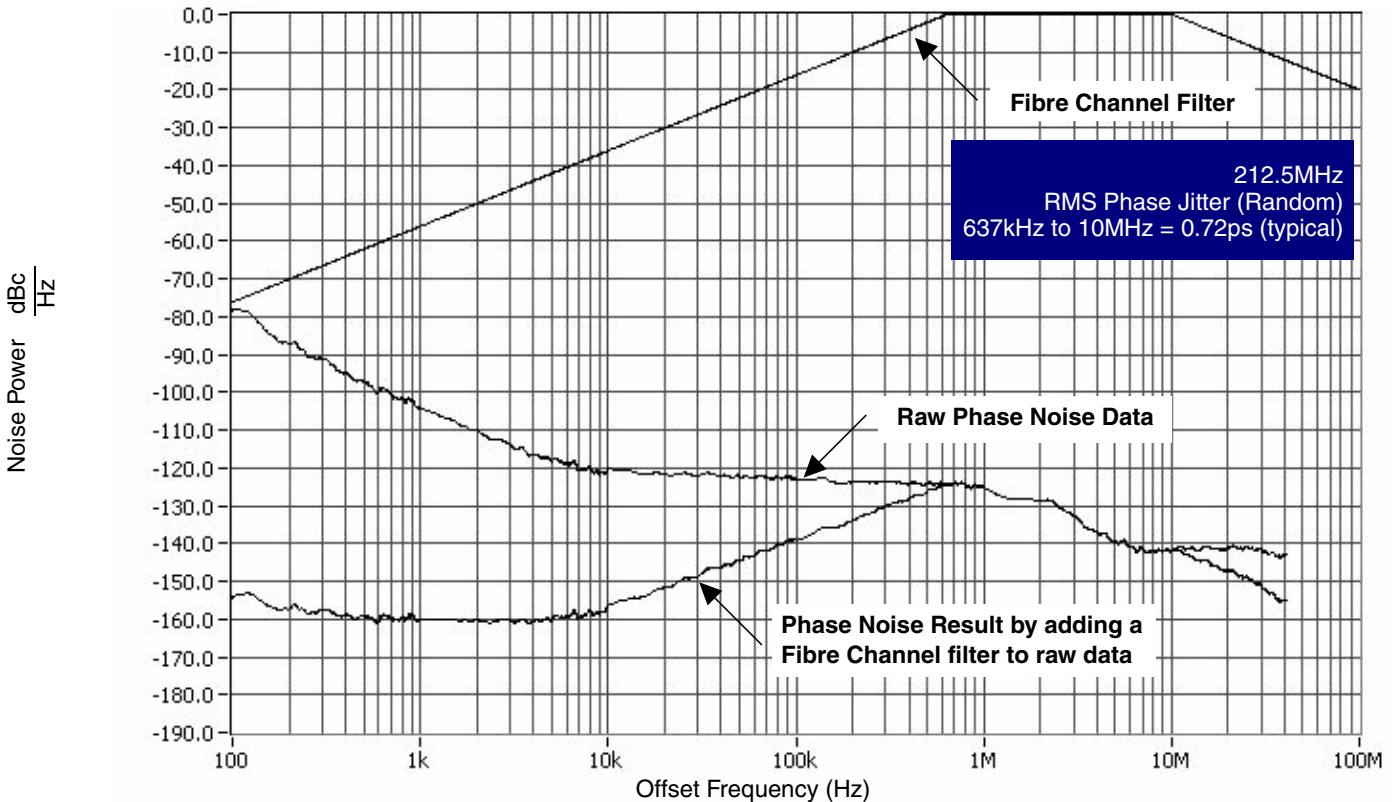

Parameter Measurement Information

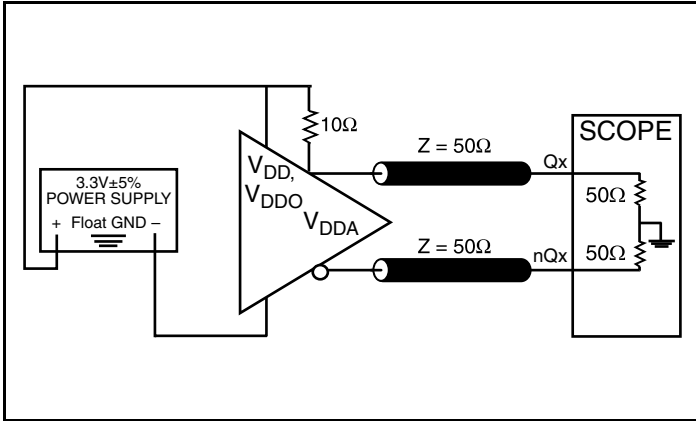

3.3V LVDS Output Load AC Test Circuit

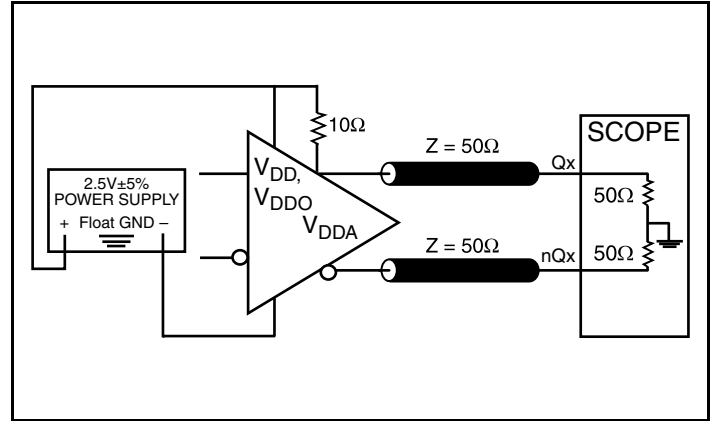

2.5V LVDS Output Load AC Test Circuit

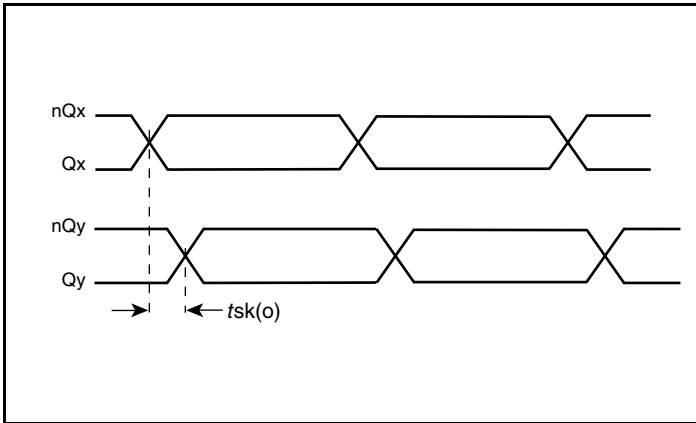

Output Skew

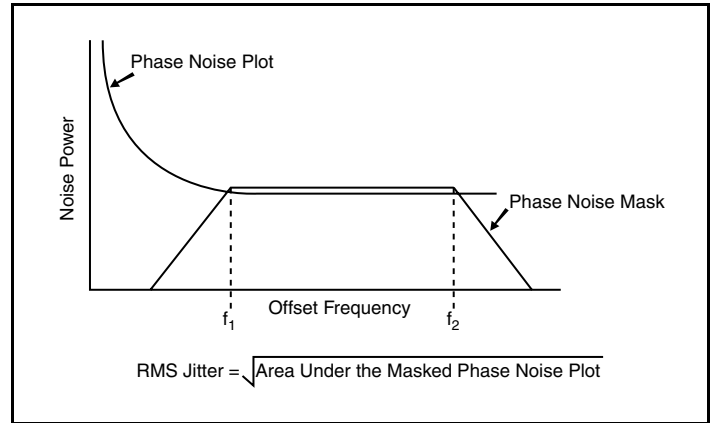

RMS Phase Jitter

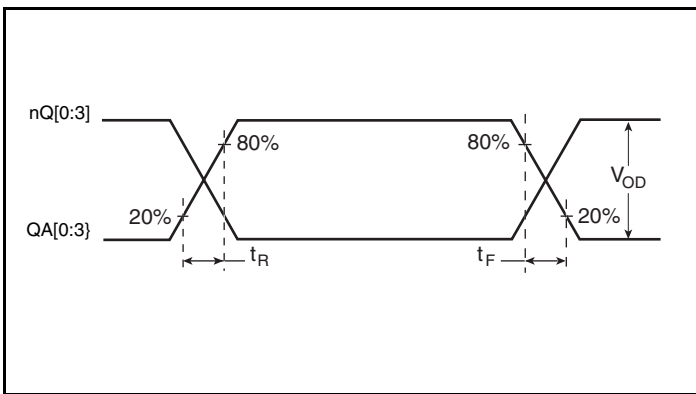

Output Rise/Fall Time

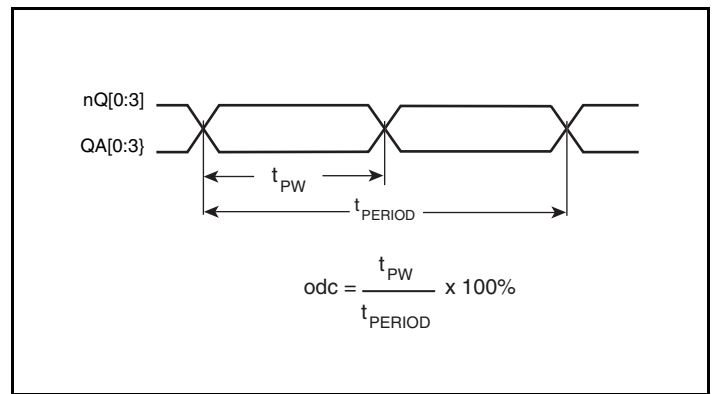

Output Duty Cycle/Pulse Width/Period

Parameter Measurement Information, continued

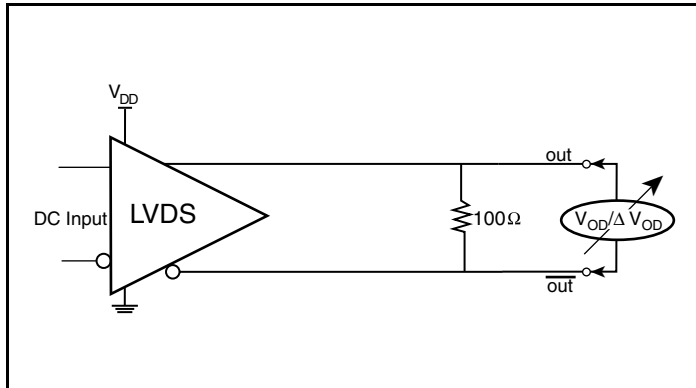

Differential Output Voltage Setup

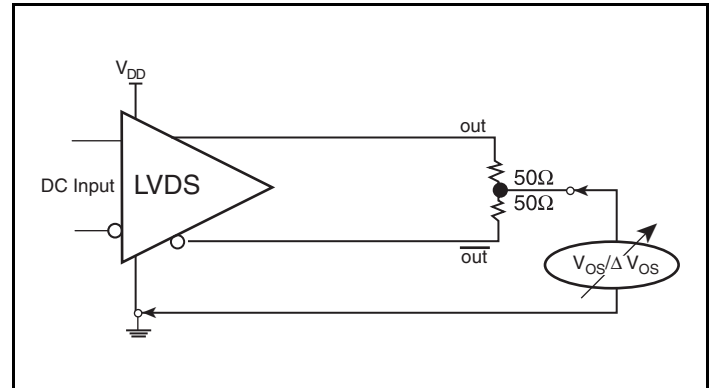

Offset Voltage Setup

Applications Information

Power Supply Filtering Technique

As in any high speed analog circuitry, the power supply pins are vulnerable to random noise. To achieve optimum jitter performance, power supply isolation is required. The ICS844004I-104 provides separate power supplies to isolate any high switching noise from the outputs to the internal PLL. V_{DD} , V_{DDA} and V_{DDO} should be individually connected to the power supply plane through vias, and 0.01μF bypass capacitors should be used for each pin. *Figure 1* illustrates this for a generic V_{DD} pin and also shows that V_{DDA} requires that an additional 10Ω resistor along with a 10μF bypass capacitor be connected to the V_{DDA} pin.

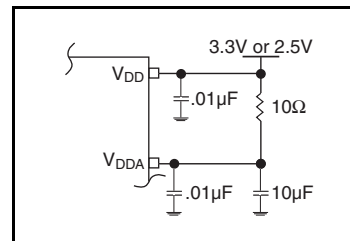

Figure 1. Power Supply Filtering

Crystal Input Interface

The ICS844004I-104 has been characterized with 18pF parallel resonant crystals. The capacitor values shown in *Figure 2* below were determined using a 26.5625MHz, 18pF parallel resonant crystal and were chosen to minimize the ppm error.

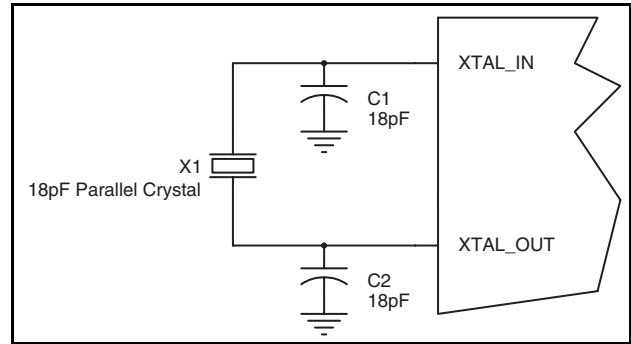

Figure 2. Crystal Input Interface

Overdriving the XTAL Interface

The XTAL_IN input can accept a single-ended LVCMOS signal through an AC coupling capacitor. A general interface diagram is shown in *Figure 3A*. The XTAL_OUT pin can be left floating. The maximum amplitude of the input signal should not exceed 2V and the input edge rate can be as slow as 10ns. This configuration requires that the output impedance of the driver (R_o) plus the series resistance (R_s) equals the transmission line impedance. In addition,

matched termination at the crystal input will attenuate the signal in half. This can be done in one of two ways. First, R_1 and R_2 in parallel should equal the transmission line impedance. For most 50Ω applications, R_1 and R_2 can be 100Ω . This can also be accomplished by removing R_1 and making R_2 50Ω . By overdriving the crystal oscillator, the device will be functional, but note, the device performance is guaranteed by using a quartz crystal.

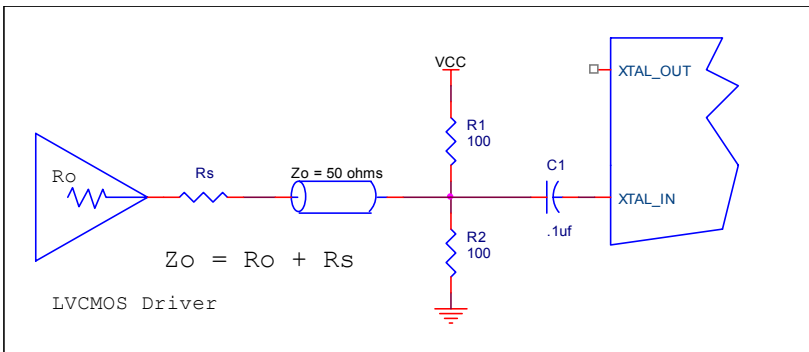

Figure 3A. General Diagram for LVCMOS Driver to XTAL Input Interface

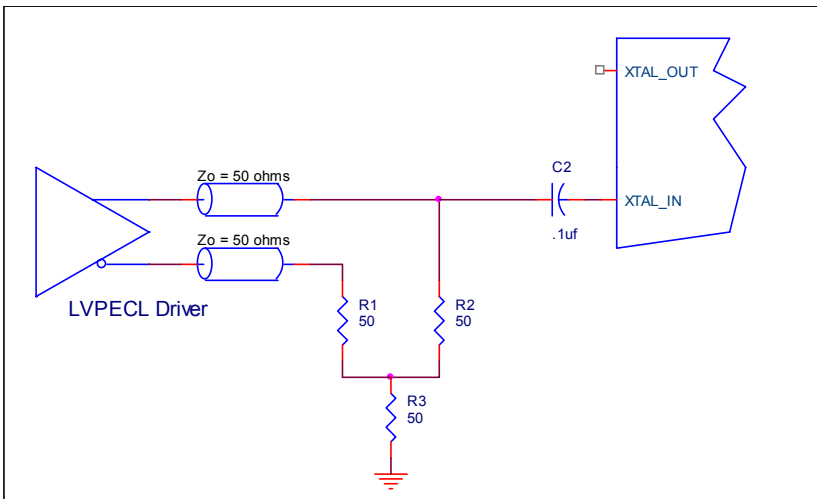

Figure 3B. General Diagram for LVPECL Driver to XTAL Input Interface

Recommendations for Unused Input and Output Pins

Inputs:

LVC MOS Control Pins

All control pins have internal pulldowns; additional resistance is not required but can be added for additional protection. A 1k Ω resistor can be used.

REF_CLK Input

For applications not requiring the use of the reference clock, it can be left floating. Though not required, but for additional protection, a 1k Ω resistor can be tied from the REF_CLK to ground.

Outputs:

LVDS Outputs

All unused LVDS output pairs can be either left floating or terminated with 100 Ω across. If they are left floating, we recommend that there is no trace attached.

LVDS Driver Termination

A general LVDS interface is shown in *Figure 4*. Standard termination for LVDS type output structure requires both a 100 Ω parallel resistor at the receiver and a 100 Ω differential transmission line environment. In order to avoid any transmission line reflection issues, the 100 Ω resistor must be placed as close to the receiver as possible. IDT offers a full line of LVDS compliant devices with two types of output structures: current source and voltage source. The standard

termination schematic as shown in *Figure 4* can be used with either type of output structure. If using a non-standard termination, it is recommended to contact IDT and confirm if the output is a current source or a voltage source type structure. In addition, since these outputs are LVDS compatible, the amplitude and common mode input range of the input receivers should be verified for compatibility with the output.

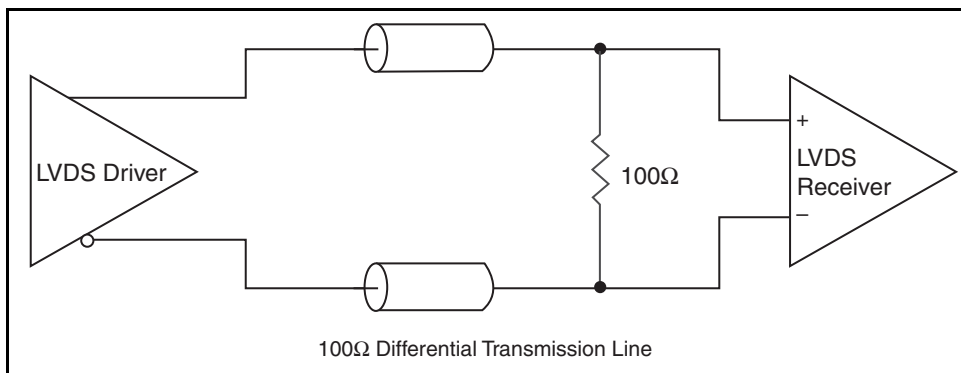

Figure 4. Typical LVDS Driver Termination

VFQFN EPAD Thermal Release Path

In order to maximize both the removal of heat from the package and the electrical performance, a land pattern must be incorporated on the Printed Circuit Board (PCB) within the footprint of the package corresponding to the exposed metal pad or exposed heat slug on the package, as shown in *Figure 5*. The solderable area on the PCB, as defined by the solder mask, should be at least the same size/shape as the exposed pad/slug area on the package to maximize the thermal/electrical performance. Sufficient clearance should be designed on the PCB between the outer edges of the land pattern and the inner edges of pad pattern for the leads to avoid any shorts.

While the land pattern on the PCB provides a means of heat transfer and electrical grounding from the package to the board through a solder joint, thermal vias are necessary to effectively conduct from the surface of the PCB to the ground plane(s). The land pattern must be connected to ground through these vias. The vias act as “heat pipes”. The number of vias (i.e. “heat pipes”) are application specific

and dependent upon the package power dissipation as well as electrical conductivity requirements. Thus, thermal and electrical analysis and/or testing are recommended to determine the minimum number needed. Maximum thermal and electrical performance is achieved when an array of vias is incorporated in the land pattern. It is recommended to use as many vias connected to ground as possible. It is also recommended that the via diameter should be 12 to 13mils (0.30 to 0.33mm) with 1oz copper via barrel plating. This is desirable to avoid any solder wicking inside the via during the soldering process which may result in voids in solder between the exposed pad/slug and the thermal land. Precautions should be taken to eliminate any solder voids between the exposed heat slug and the land pattern. Note: These recommendations are to be used as a guideline only. For further information, please refer to the Application Note on the Surface Mount Assembly of Amkor’s Thermally/Electrically Enhance Leadframe Base Package, Amkor Technology.

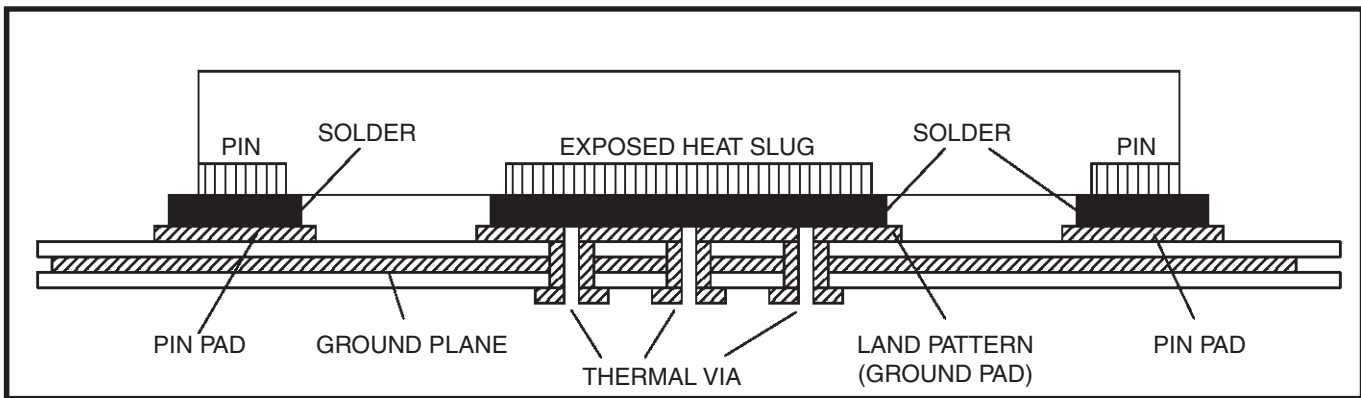

Figure 5. P.C. Assembly for Exposed Pad Thermal Release Path – Side View (drawing not to scale)

Schematic Example

Figure 6 shows an example of ICS844004I-104 application schematic. In this example, the device is operated at $V_{DD} = V_{DDO} = 3.3V$. The 18pF parallel resonant 25MHz crystal is used. The $C1 = 33pF$ and $C2 = 27pF$ are recommended for frequency accuracy. For

different board layouts, the C1 and C2 may be slightly adjusted for optimizing frequency accuracy. Two examples of LVDS for receiver without built-in termination are shown in this schematic.

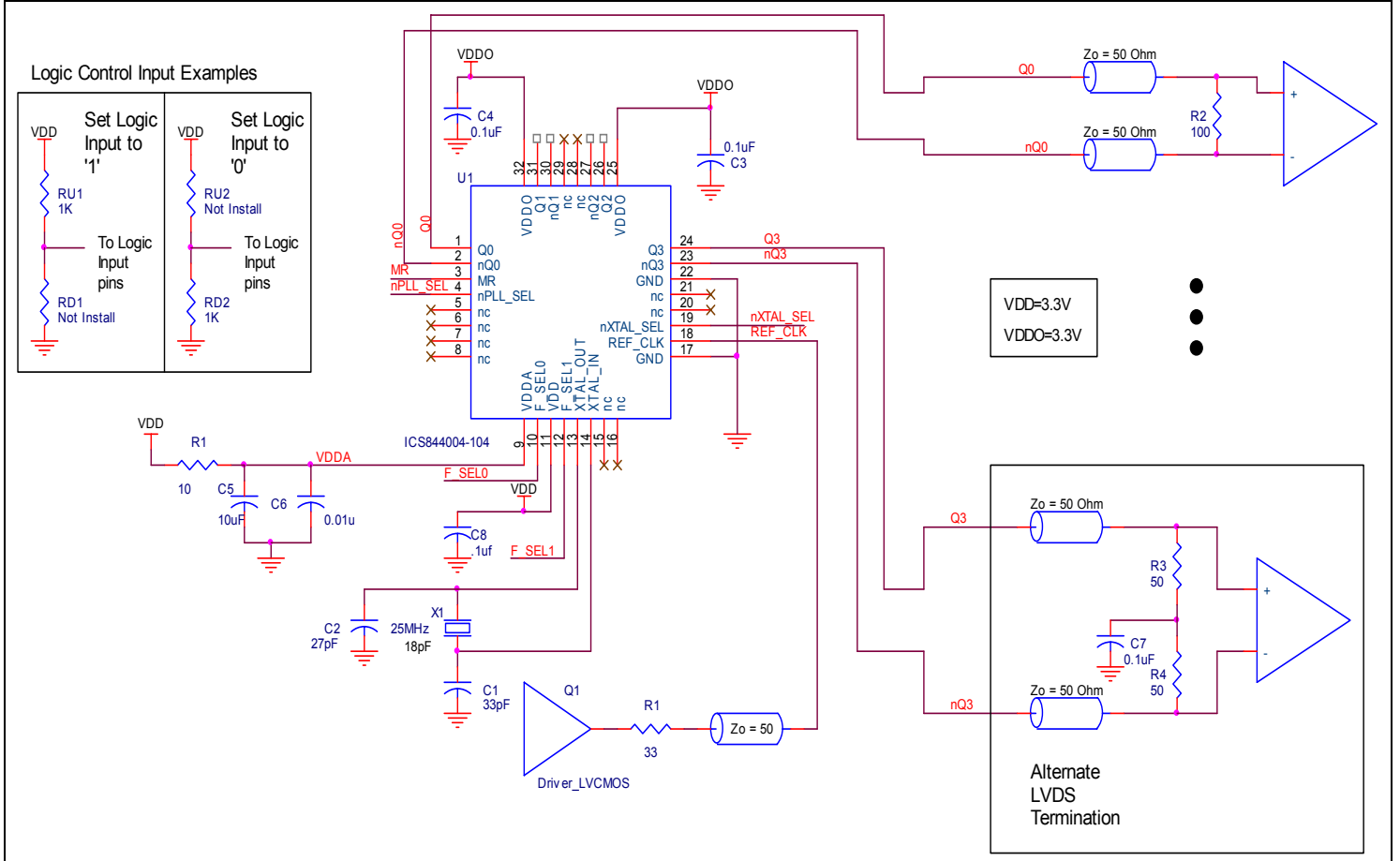

Figure 6. ICS844004I-104 Schematic Layout

Power Considerations

This section provides information on power dissipation and junction temperature for the ICS844004I-104. Equations and example calculations are also provided.

1. Power Dissipation.

The total power dissipation for the ICS844004I-104 is the sum of the core power plus the analog power plus the power dissipated in the load(s). The following is the power dissipation for $V_{DD} = 3.3V + 5\% = 3.465V$, which gives worst case results.

- Power (core)_{MAX} = $V_{DD_MAX} * (I_{DD_MAX} + I_{DDA_MAX}) = 3.465V * (105mA + 12mA) = \mathbf{405.4mW}$
- Power (outputs)_{MAX} = $V_{DDO_MAX} * I_{DDO_MAX} = 3.465V * 120mA = \mathbf{415.8mW}$

Total Power_{MAX} = 405.4mW + 415.8mW = **821.2mW**

2. Junction Temperature.

Junction temperature, T_j , is the temperature at the junction of the bond wire and bond pad, and directly affects the reliability of the device. The maximum recommended junction temperature is 125°C. Limiting the internal transistor junction temperature, T_j , to 125°C ensures that the bond wire and bond pad temperature remains below 125°C.

The equation for T_j is as follows: $T_j = \theta_{JA} * Pd_total + T_A$

T_j = Junction Temperature

θ_{JA} = Junction-to-Ambient Thermal Resistance

Pd_total = Total Device Power Dissipation (example calculation is in section 1 above)

T_A = Ambient Temperature

In order to calculate junction temperature, the appropriate junction-to-ambient thermal resistance θ_{JA} must be used. Assuming no air flow and a multi-layer board, the appropriate value is 42.4°C/W per Table 7 below.

Therefore, T_j for an ambient temperature of 85°C with all outputs switching is:

$$85^\circ\text{C} + 0.821\text{W} * 42.4^\circ\text{C/W} = 119.8^\circ\text{C}. \text{ This is below the limit of } 125^\circ\text{C}.$$

This calculation is only an example. T_j will obviously vary depending on the number of loaded outputs, supply voltage, air flow and the type of board (multi-layer).

Table 7. Thermal Resistance θ_{JA} for 32 Lead VFQFN, Forced Convection

θ_{JA} vs. Air Flow			
Meters per Second	0	1	2.5
Multi-Layer PCB, JEDEC Standard Test Boards	42.4°C/W	37.0°C/W	33.2°C/W

Reliability Information

Table 8. θ_{JA} vs. Air Flow Table for a 32 Lead VFQFN

θ_{JA} vs. Air Flow			
Meter per Second	0	1	2.5
Multi-Layer PCB, JEDEC Standard Test Boards	42.4°C/W	37.0°C/W	33.2°C/W

Transistor Count

The transistor count for ICS844004I-104 is: 2914

Package Outline and Package Dimensions

Package Outline - K Suffix for 32-Lead VFQFN

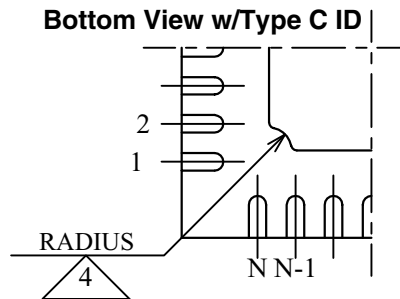
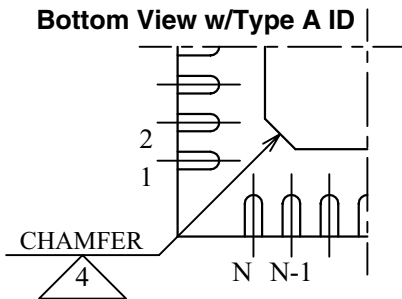
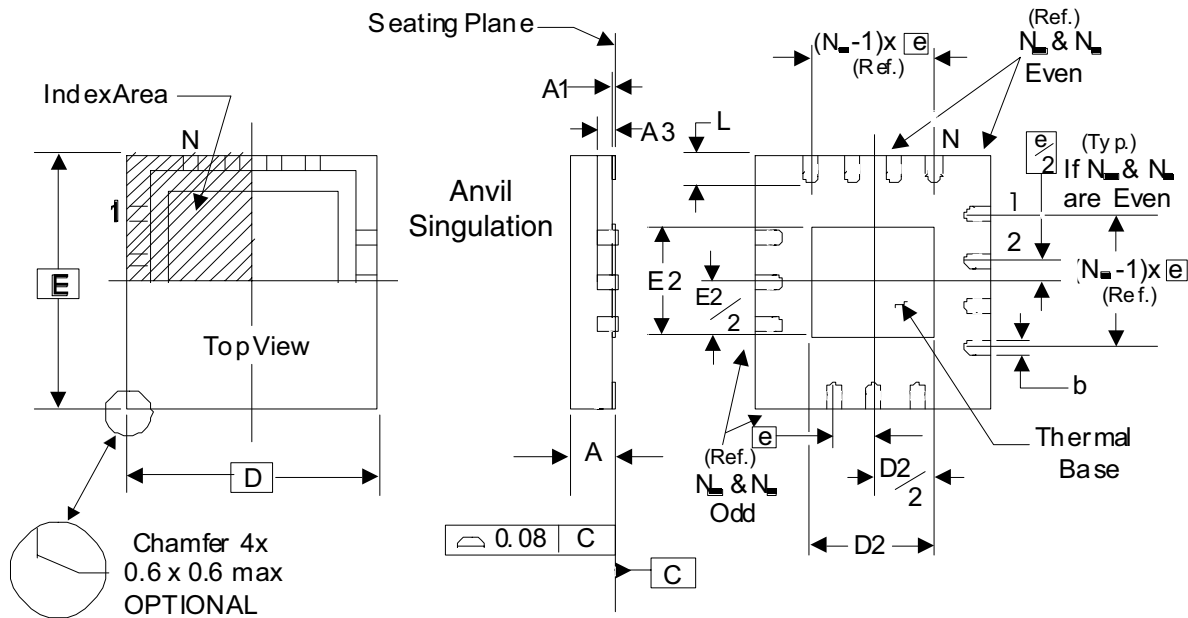

There are 2 methods of indicating pin 1 corner at the back of the VFQFN package are:

1. Type A: Chamfer on the paddle (near pin 1)
2. Type C: Mouse bite on the paddle (near pin 1)

Table 9. Package Dimensions for 32-Lead VFQFN

JEDEC Variation: VHHD-2/-4		
All Dimensions in Millimeters		
Symbol	Minimum	Maximum
N	32	
A	0.80	1.00
$A1$	0	0.05
$A3$	0.25 Ref.	
b	0.18	0.30
N_D & N_E	8	
D & E	5.00 Basic	
$D2$ & $E2$	3.0	3.3
e	0.50 Basic	
L	0.30	0.50

NOTE: The following package mechanical drawing is a generic drawing that applies to any pin count VFQFN package. This drawing is not intended to convey the actual pin count or pin layout of this device. The pin count and pinout are shown on the front page. The package dimensions are in Table 9.

Reference Document: JEDEC Publication 95, MO-220

Ordering Information

Table 10. Ordering Information

Part/Order Number	Marking	Package	Shipping Packaging	Temperature
844004AKI-104	ICS004AI104	32 Lead VFQFN	Tray	-40°C to 85°C
844004AKI-104T	ICS004AI104	32 Lead VFQFN	2500 Tape & Reel	-40°C to 85°C
844004AKI-104LF	ICS04AI104L	"Lead-Free" 32 Lead VFQFN	Tray	-40°C to 85°C
844004AKI-104LFT	ICS04AI104L	"Lead-Free" 32 Lead VFQFN	2500 Tape & Reel	-40°C to 85°C

NOTE: Parts that are ordered with an "LF" suffix to the part number are the Pb-Free configuration and are RoHS compliant.

While the information presented herein has been checked for both accuracy and reliability, Integrated Device Technology (IDT) assumes no responsibility for either its use or for the infringement of any patents or other rights of third parties, which would result from its use. No other circuits, patents, or licenses are implied. This product is intended for use in normal commercial and industrial applications. Any other applications, such as those requiring high reliability or other extraordinary environmental requirements are not recommended without additional processing by IDT. IDT reserves the right to change any circuitry or specifications without notice. IDT does not authorize or warrant any IDT product for use in life support devices or critical medical instruments.

Revision History Sheet

Rev	Table	Page	Description of Change	Date
A	T5A - T5B	5	AC Characteristics Tables - added Thermal Note.	12/15/10
		9	Updated <i>Overdriving the Crystal Interface</i> section.	
		10	Updated <i>LVDS Driver Termination</i> section.	
		15	Updated <i>Package Outline</i> section.	
	T10	16	Ordering Information Table - corrected marking. Updated header/footer of datasheet.	

We've Got Your Timing Solution



6024 Silver Creek Valley Road
San Jose, California 95138

Sales

800-345-7015 (inside USA)
+408-284-8200 (outside USA)
Fax: 408-284-2775
www.IDT.com/go/contactIDT

Technical Support

netcom@idt.com
+480-763-2056

DISCLAIMER Integrated Device Technology, Inc. (IDT) and its subsidiaries reserve the right to modify the products and/or specifications described herein at any time and at IDT's sole discretion. All information in this document, including descriptions of product features and performance, is subject to change without notice. Performance specifications and the operating parameters of the described products are determined in the independent state and are not guaranteed to perform the same way when installed in customer products. The information contained herein is provided without representation or warranty of any kind, whether express or implied, including, but not limited to, the suitability of IDT's products for any particular purpose, an implied warranty of merchantability, or non-infringement of the intellectual property rights of others. This document is presented only as a guide and does not convey any license under intellectual property rights of IDT or any third parties.

IDT's products are not intended for use in life support systems or similar devices where the failure or malfunction of an IDT product can be reasonably expected to significantly affect the health or safety of users. Anyone using an IDT product in such a manner does so at their own risk, absent an express, written agreement by IDT.

Integrated Device Technology, IDT and the IDT logo are registered trademarks of IDT. Other trademarks and service marks used herein, including protected names, logos and designs, are the property of IDT or their respective third party owners.

Copyright 2010. All rights reserved.