

# PLC-ASC-UI-IN - Analog module



2906916

<https://www.phoenixcontact.com/us/products/2906916>

Please be informed that the data shown in this PDF document is generated from our online catalog. Please find the complete data in the user documentation. Our general terms of use for downloads are valid.



Analog input module for PLC logic modules (Generation 2 only), single-channel, signal type (4 mA ... 20 mA, 0 mA ... 20 mA, 0 V ... 10 V, 2 V ... 10 V) can be configured via DIP switch, screw connection

## Commercial data

Item number	2906916
Packing unit	1 pc
Minimum order quantity	1 pc
Sales key	C424
Product key	CK2622
Catalog page	Page 430 (C-5-2017)
GTIN	4055626153773
Weight per piece (including packing)	79.9 g
Weight per piece (excluding packing)	53.3 g
Customs tariff number	85389099
Country of origin	DE

## Technical data

### Notes

General	For proper use, the specifications of the installation directive (see Downloads) must be observed.
---------	--

### Product properties

Product type	Extension module
Product family	PLC logic
Operating mode	100% operating factor

### Insulation characteristics

Insulation	Basic insulation
------------	------------------

### Insulation characteristics: Air clearances and creepage distances

Insulation	Basic insulation
Overvoltage category	III
Pollution degree	2

### Electrical properties

#### Air clearances and creepage distances

Rated insulation voltage	50 V
Rated surge voltage	0.5 kV

#### Supply

Rated control circuit supply voltage $U_S$	24 V DC
Rated control supply voltage range with reference to $U_S$	0.8 ... 1.1
Rated control supply current $I_S$	13 mA
Protective circuit	Reverse polarity protection
	Surge protection

### Input data

#### Analog current input

Number of inputs	1
Current input signal	0 mA ... 20 mA
	4 mA ... 20 mA
Input resistance current input	40 $\Omega$
Maximum temperature coefficient	0.01 %/K
Maximum transmission error	1 %
Surge voltage protection	> 33 V
Resolution	10 bit (scaled to 0 to 1000)

#### Analog voltage input

Number of inputs	1
Voltage input signal	0 V ... 10 V

# PLC-ASC-UI-IN - Analog module



2906916

<https://www.phoenixcontact.com/us/products/2906916>

	2 V ... 10 V
Input resistance of voltage input	> 120 kΩ
Maximum temperature coefficient	0.01 %/K
Maximum transmission error	1 %
Surge voltage protection	> 33 V
Resolution	10 bit (scaled to 0 to 1000)

## Output data

### Digital

Output name	Digital output
Switching voltage range	5 V DC ... 30 V DC
Switching current	≤ 3 mA

## Connection data

Connection method	Screw connection
Stripping length	8 mm
Screw thread	M3
Conductor cross section rigid	0.14 mm <sup>2</sup> ... 2.5 mm <sup>2</sup>
Conductor cross section flexible	0.14 mm <sup>2</sup> ... 2.5 mm <sup>2</sup>
	0.2 mm <sup>2</sup> ... 2.5 mm <sup>2</sup> (Single ferrule)
	2x 0.5 mm <sup>2</sup> ... 1.5 mm <sup>2</sup> (TWIN ferrule)
Conductor cross section AWG	26 ... 14
Tightening torque	0.6 Nm ... 0.8 Nm

## Signaling

Operating voltage display	Green LED
Error indication	Red LED

## Dimensions

Width	6.2 mm
Height	80 mm
Depth	86 mm

## Environmental and real-life conditions

### Ambient conditions

Degree of protection	IP20
Ambient temperature (operation)	-20 °C ... 50 °C
Ambient temperature (storage/transport)	-20 °C ... 70 °C

## Approvals

### CE

Certificate	CE-compliant
-------------	--------------

### UL, USA/Canada

# PLC-ASC-UI-IN - Analog module



2906916

<https://www.phoenixcontact.com/us/products/2906916>

Identification	UL 508 Listed
----------------	---------------

## Standards and regulations

### Air clearances and creepage distances

Standards/regulations	DIN EN 50178
-----------------------	--------------

## Mounting

Mounting type	DIN rail mounting
Assembly instructions	in rows with zero spacing
Mounting position	any

# PLC-ASC-UI-IN - Analog module

2906916

<https://www.phoenixcontact.com/us/products/2906916>

## Drawings

Block diagram

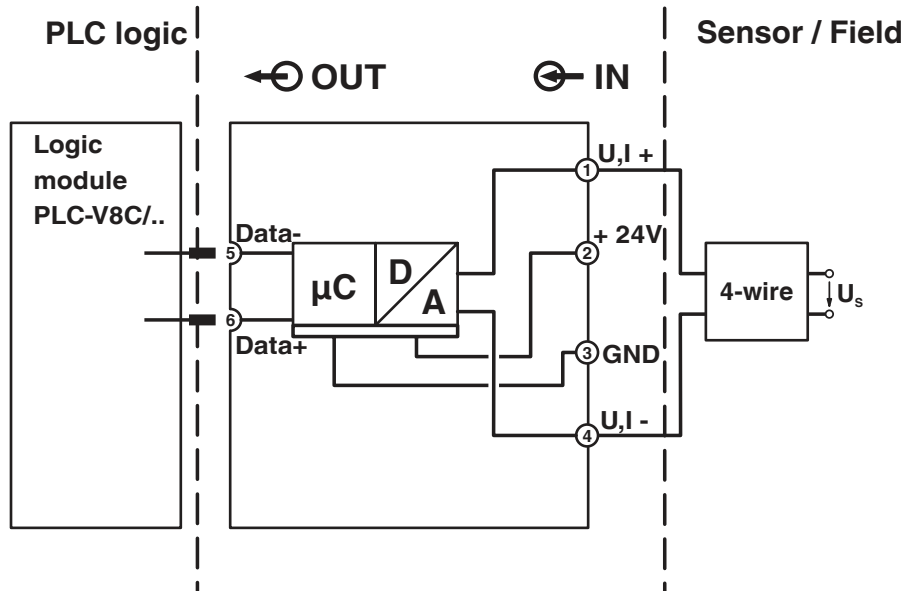

# PLC-ASC-UI-IN - Analog module



2906916

<https://www.phoenixcontact.com/us/products/2906916>

## Approvals

To download certificates, visit the product detail page: <https://www.phoenixcontact.com/us/products/2906916>



**EAC**

Approval ID: RU\*DE.\*08.B.01517/19



**UL Listed**

Approval ID: FILE E 238705



**cUL Listed**

Approval ID: FILE E 238705

**cULus Listed**

# PLC-ASC-UI-IN - Analog module



2906916

<https://www.phoenixcontact.com/us/products/2906916>

## Classifications

### ECLASS

ECLASS-11.0	27242201
ECLASS-12.0	27242201
ECLASS-13.0	27242201

### ETIM

ETIM 8.0	EC001420
----------	----------

### UNSPSC

UNSPSC 21.0	32151600
-------------	----------

# PLC-ASC-UI-IN - Analog module



2906916

<https://www.phoenixcontact.com/us/products/2906916>

## Environmental product compliance

REACH SVHC	Lead 7439-92-1
China RoHS	Environmentally Friendly Use Period = 50 years
	For information on hazardous substances, refer to the manufacturer's declaration available under "Downloads"

Phoenix Contact 2023 © - all rights reserved

<https://www.phoenixcontact.com>

Phoenix Contact USA  
586 Fulling Mill Road  
Middletown, PA 17057, United States  
(+717) 944-1300  
[info@phoenixcon.com](mailto:info@phoenixcon.com)