

DO NOT SCALE FROM THIS PRINT

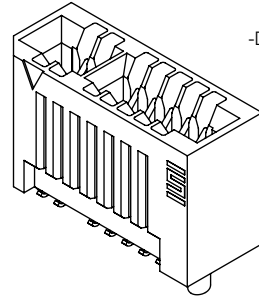
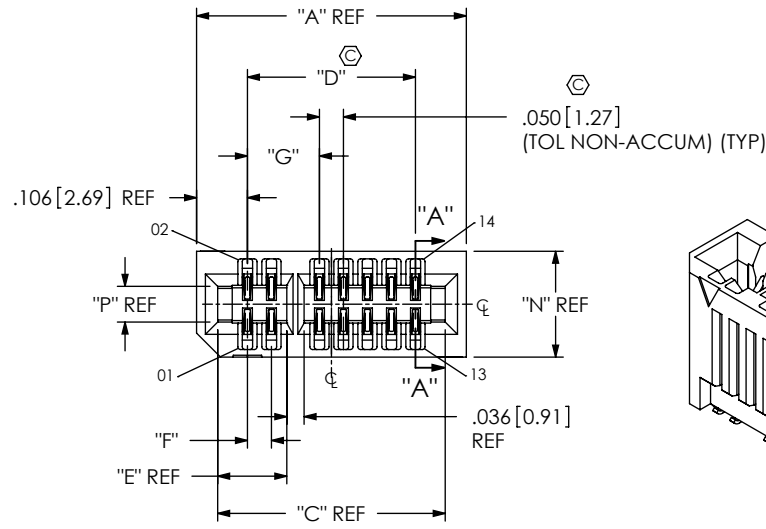

No OF POSITIONS (PER ROW)
 -05, -08, -20, -30, -40, -50, *-60, *-70
 (SEE TABLE 2 FOR POSITION REMOVED TO POLARIZE)

CARD THICKNESS
 -01: .062" [1.57mm] THICK
 -02: .093" [2.36mm] THICK

PLATING SPECIFICATION
 -L: SELECTIVE LIGHT GOLD/TIN TAIL (USE C-308-01-L)

ROW SPECIFICATION
 -DV: DOUBLE ROW VERTICAL

PACKAGING
 BLANK: TUBES (SEE NOTE 7)
 -TR: TAPE & REEL (-05 THRU -50 POS ONLY) (SEE NOTE 8 & 9)
 -FR: FULL REEL QTY TAPE & REEL (-05 THRU -50 POS ONLY) (SEE NOTE 8 & 9)

PICK & PLACE OPTION
 -K: POLYIMIDE FILM PAD (SEE TABLE 6, SHT 2) AVAILABLE WITH -TR ONLY. (-05 THRU -50 POS ONLY)

OPTION
 -NP: NON-POLARIZED (-05, -08, -20 & -30 POSITIONS ONLY) (USE MECF-XX-XX-DV-NP)
 -WT: WELD TABS (STANDARD ON -02 CARD THICKNESS) (OPTIONAL ON -01 CARD THICKNESS)

(* = NOT TOOLED)

TABLE 1

No OF POS	COPLANARITY
-05 THRU -30	.0040 [0.102]
-40 THRU -70	.0060 [0.157]

TABLE 2

No OF POS	POLARIZED POSITIONS	"Y"
** -05	3, 4	2
** -08	5, 6	2
** -20	15, 16	2
** -30	21, 22	2
** -40	31, 32	2
** -50	41, 42	2
*** -60	31, 32 & 63, 64	4
*** -70	53, 54 & 115, 116	4

(* = NOT TOOLED)
 (** = TOTAL NUMBER OF POSITIONS WILL BE REDUCED BY "Y" FOR POLARIZATION)

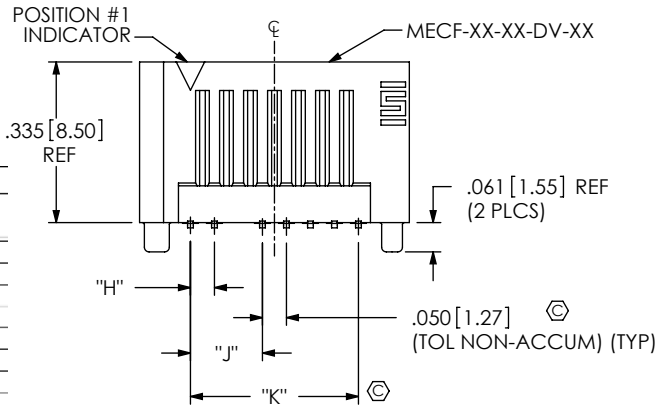

TABLE 3

No. OF POS. PER ROW	"A"	"B"	"C"	"D"	"E"
-05	0.412 [10.46]	0.340 [8.64]	0.3240 [8.230]	0.200 [5.08]	0.094 [2.39]
-08	0.562 [14.27]	0.490 [12.45]	0.4740 [12.040]	0.350 [8.89]	0.144 [3.66]
-20	1.162 [29.51]	1.090 [27.69]	1.0740 [27.280]	0.950 [24.13]	0.394 [10.01]
-30	1.662 [42.21]	1.590 [40.39]	1.5740 [39.980]	1.450 [36.83]	0.544 [13.82]
-40	2.162 [54.91]	2.090 [53.09]	2.0740 [52.680]	1.950 [49.53]	0.794 [20.17]
-50	2.662 [67.61]	2.590 [65.79]	2.5740 [65.380]	2.450 [62.23]	1.044 [26.52]
*-60	3.162 [80.31]	3.090 [78.49]	3.0740 [78.080]	2.950 [74.93]	0.794 [20.17]
*-70	3.662 [93.01]	3.590 [91.19]	3.5740 [90.780]	3.450 [87.63]	1.344 [34.14]

No. OF POS. PER ROW	"F"	"G"	"H"	"J"	"K"
-05	N/A N/A	0.1000 [2.540]	N/A N/A	0.100 [2.54]	0.200 [5.08]
-08	0.0500 [1.270]	0.1500 [3.810]	0.050 [1.27]	0.150 [3.81]	0.350 [8.89]
-20	0.3000 [7.620]	0.4000 [10.160]	0.300 [7.62]	0.400 [10.16]	0.950 [24.13]
-30	0.4500 [11.430]	0.5500 [13.970]	0.450 [11.43]	0.550 [13.97]	1.450 [36.83]
-40	0.7000 [17.780]	0.8000 [20.320]	0.700 [17.78]	0.800 [20.32]	1.950 [49.53]
-50	0.9500 [24.130]	1.0500 [26.670]	0.950 [24.13]	1.050 [26.67]	2.450 [62.23]
*-60	0.7000 [17.780]	0.8000 [20.320]	0.700 [17.78]	0.800 [20.32]	2.950 [74.93]
*-70	1.2500 [31.750]	1.3500 [34.290]	1.250 [31.75]	1.350 [34.29]	3.450 [87.63]

(* = NOT TOOLED)

TABLE 4

CARD THICKNESS	"N"	"P"	"R"	"S"
-01 (.062 in)	0.220 [5.60]	0.074 [1.89]	0.022 [0.55]	0.183 [4.66]
-02 (.093 in)	0.248 [6.30]	0.106 [2.68]	0.053 [1.34]	0.215 [5.45]

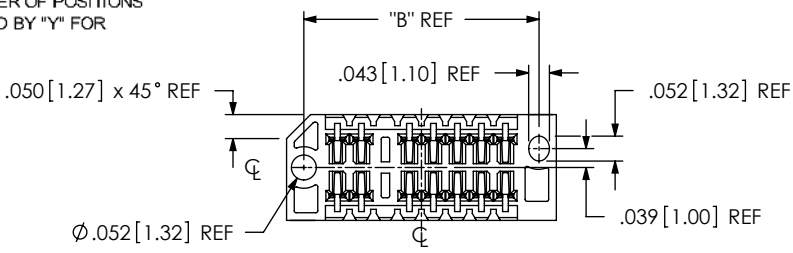

FIG 1 (MECF-08-01-XX-DV-XX SHOWN)

- NOTES:
1. (C) REPRESENTS A CRITICAL DIMENSION.
 2. BURR ALLOWANCE: .0015 [0.04] MAX.
 3. MINIMUM PUSHOUT FORCE: 0.50 LBS.
 4. ALL TAIL TO TAIL DIMENSIONS MEASURED TIP TO TIP.
 5. NOTE DELETED
 6. MATING EDGE CARD THICKNESS TOLERANCE NOT TO EXCEED ±10%
 7. TUBES ARE STANDARD PACKAGING.
 8. ORDERS WILL BE PACKAGED ACCORDING TO THE SAMTEC PACKAGING EFFICIENCY STANDARDS (SPES) FOUND ON WWW.SAMTEC.COM
 9. ATTACH LABEL TO EACH REEL

UNLESS OTHERWISE SPECIFIED, DIMENSIONS ARE IN INCHES [MILLIMETERS] TOLERANCES ARE: DECIMALS ANGLES .XX: ± .01 [0.3] 2° .XXX: ± .005 [0.13] .XXXX: ± .0020 [0.051]	* PROPRIETARY NOTE * THIS DOCUMENT CONTAINS CONFIDENTIAL AND PROPRIETARY INFORMATION AND ALL DESIGN, MANUFACTURING, REPRODUCTION, USE, PATENT RIGHTS AND SALES RIGHTS ARE EXPRESSLY RESERVED BY SAMTEC, INC. THIS DOCUMENT SHALL NOT BE DISCLOSED, IN WHOLE OR PART, TO ANY UNAUTHORIZED PERSON OR ENTITY NOR REPRODUCED, TRANSFERRED OR INCORPORATED IN ANY OTHER PROJECT IN ANY MANNER WITHOUT THE EXPRESS WRITTEN CONSENT OF SAMTEC, INC.	520 PARK EAST BLVD, NEW ALBANY, IN 47150 PHONE: 812-944-6733 FAX: 812-948-5047 e-Mail: info@SAMTEC.com code: 55322

F:\DVG\MISC\MKTG\MECF-XX-XX-XX-DV-XX-X-XX-MKT.SLDDRW

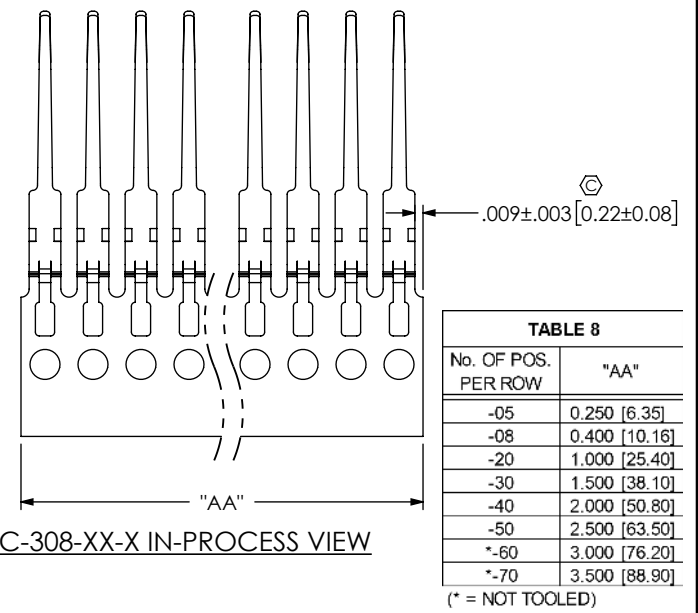
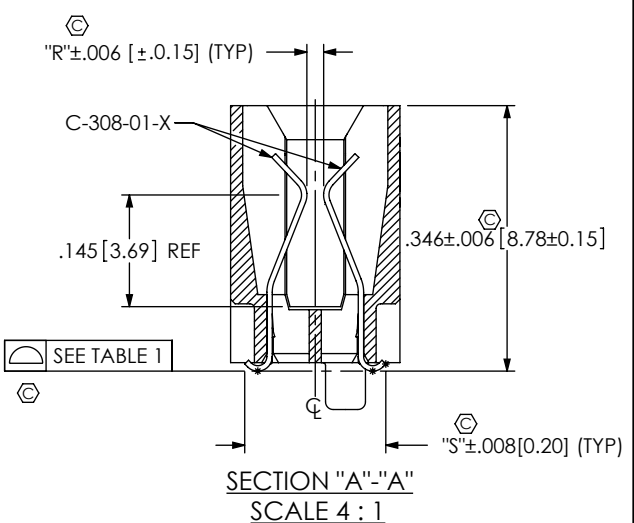
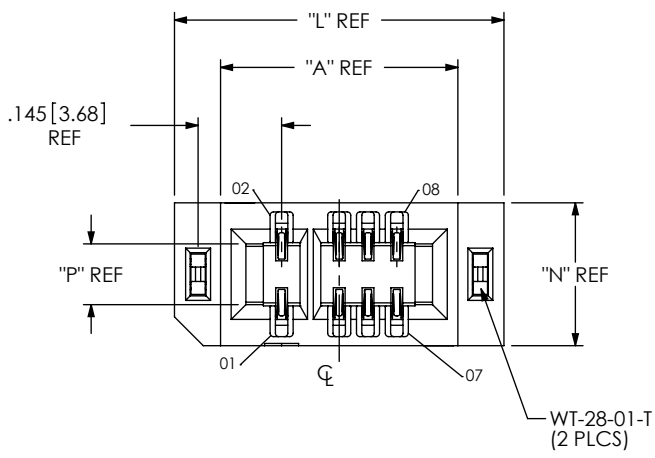

TABLE 8

No. OF POS. PER ROW	"AA"
-05	0.250 [6.35]
-08	0.400 [10.16]
-20	1.000 [25.40]
-30	1.500 [38.10]
-40	2.000 [50.80]
-50	2.500 [63.50]
*-60	3.000 [76.20]
*-70	3.500 [88.90]

(* = NOT TOOLED)

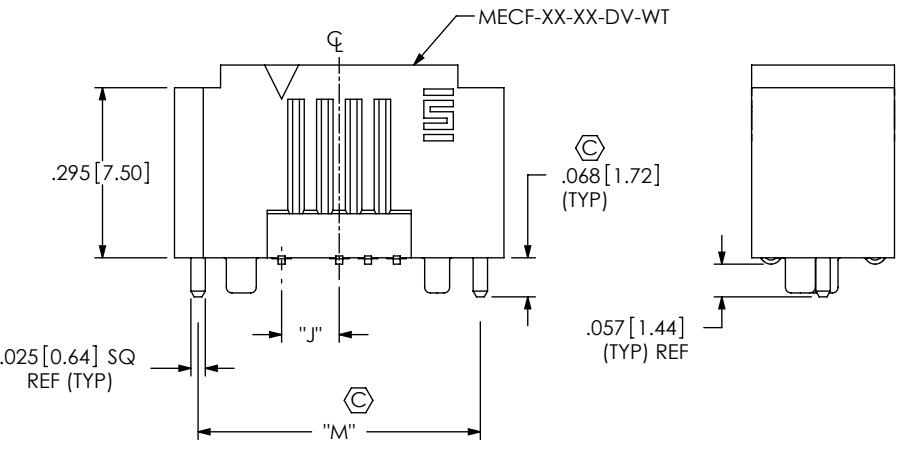

FIG 2
 (MECF-05-02-XX-DV-WT SHOWN)
 (SAME AS FIG 1, EXCEPT AS SHOWN)

TABLE 6

No. OF POS. PER ROW	"L"	"M"
-05	0.572 [14.53]	0.490 [12.45]
-08	0.722 [18.34]	0.640 [16.26]
-20	1.322 [33.58]	1.240 [31.50]
-30	1.822 [46.28]	1.740 [44.20]
-40	2.322 [58.98]	2.240 [56.90]
-50	2.822 [71.68]	2.740 [69.60]
*-60	3.322 [84.38]	3.240 [82.30]
*-70	3.822 [97.08]	3.740 [95.00]

(* = NOT TOOLED)

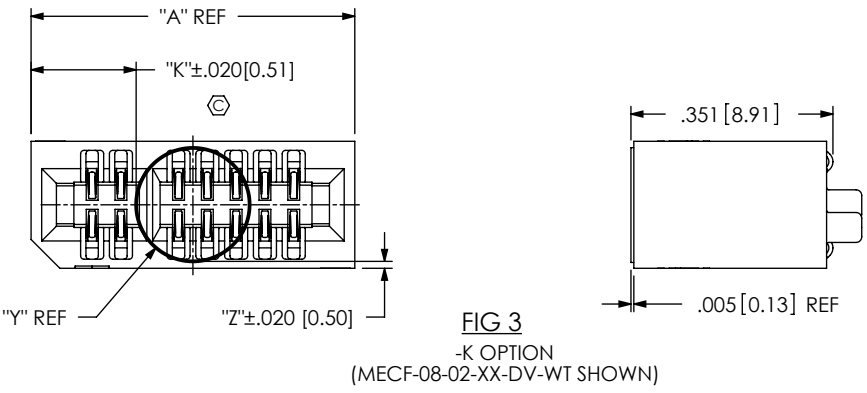

TABLE 6

BOARD THICKNESS	"Y"	"Z"	"K"					KAPTON CALL-OUT	
			No OF POSITIONS PER ROW						
			-05	-08	-20	-30	-40	-50	
-01	.197 [5.00]	.012 [.30]	.108 [2.74]	.183 [4.65]	.483 [12.27]	.733 [18.62]	.983 [24.97]	1.233 [31.32]	K-DOT-.197-.344-.005
-02	.236 [5.70]	.006 [.15]	.088 [2.24]	.163 [4.14]	.463 [11.78]	.713 [18.11]	.963 [24.48]	1.213 [30.81]	K-DOT-.236-.343-.005
-01 WITH -WT	.197 [5.00]	.012 [.30]	.188 [4.78]	.263 [6.68]	.563 [14.30]	.813 [20.65]	1.063 [27.00]	1.313 [33.35]	K-DOT-.197-.344-.005
-02 WITH -WT	.236 [5.72]	.006 [.15]	.168 [4.42]	.243 [6.32]	.543 [13.94]	.793 [20.29]	1.043 [26.64]	1.293 [32.99]	K-DOT-.236-.343-.005

PROPRIETARY NOTE
 THIS DOCUMENT CONTAINS CONFIDENTIAL AND PROPRIETARY INFORMATION AND ALL DESIGN, MANUFACTURING, REPRODUCTION, USE, PATENT RIGHTS AND SALES RIGHTS ARE EXPRESSLY RESERVED BY SAMTEC, INC. THIS DOCUMENT SHALL NOT BE DISCLOSED, IN WHOLE OR PART, TO ANY UNAUTHORIZED PERSON OR ENTITY NOR REPRODUCED, TRANSFERRED OR INCORPORATED IN ANY OTHER PROJECT IN ANY MANNER WITHOUT THE EXPRESS WRITTEN CONSENT OF SAMTEC, INC.

DO NOT SCALE DRAWING
 SHEET SCALE: 1:0.444444

samtec
 520 PARK EAST BLVD, NEW ALBANY, IN 47150
 PHONE: 812-944-6733 FAX: 812-948-5047
 e-Mail: info@SAMTEC.com code: 53322

DESCRIPTION:
 MECF .050" EDGE CARD ASSEMBLY

DWG. NO.
MECF-XX-XX-XX-DV-XX-X-XX

BY: KNOWLDEN 3/12/10 SHEET 2 OF 3

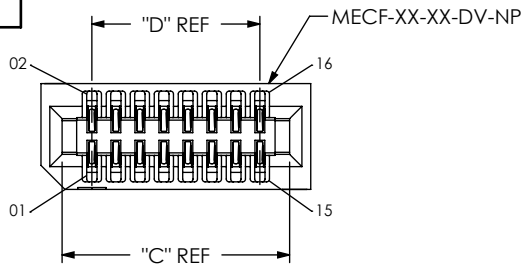

FIG 4
(MECF-08-01-XX-DV-NP SHOWN)
(SAME AS FIG 1, EXCEPT AS SHOWN)

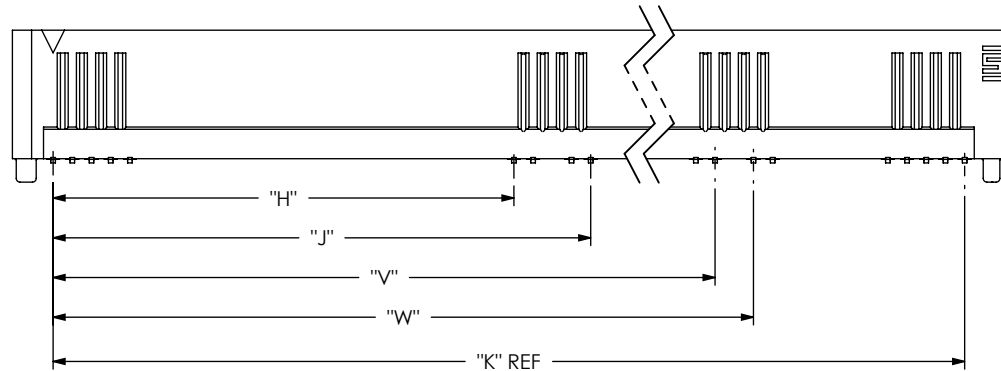
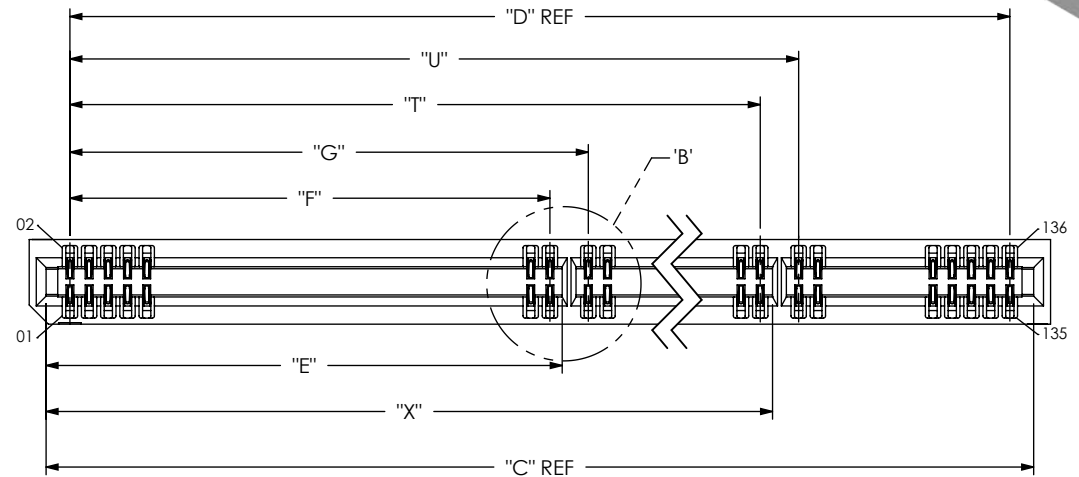

TABLE 7

No. OF POS. PER ROW	"T"	"U"	"V"	"W"	"X"
*-60	1.5000 [38.100]	1.600 [40.640]	1.500 [38.10]	1.600 [40.64]	1.594 [40.49]
*-70	2.8000 [71.120]	2.900 [73.660]	2.800 [71.12]	2.900 [73.66]	2.894 [73.51]

(* = NOT TOOLED)
FIG 5
(MECF-70-01-XX-DV-XX SHOWN)
(SAME AS FIG 1, EXCEPT AS SHOWN)
(SOME CENTER FEATURES REMOVED FOR CLARITY)
(NOT TOOLED)

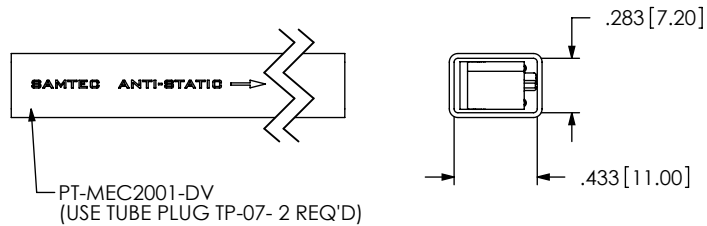
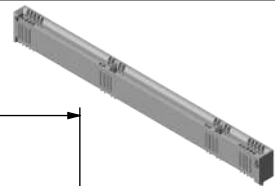
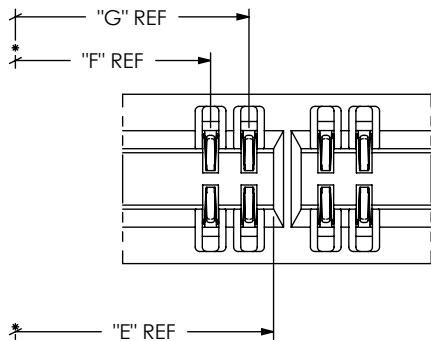

FIG 6
(MECF-XX-02-XX-DV-WT)
(SHOWN IN PACKAGING TUBE)



DETAIL 'B'
SCALE 4 : 1

F:\DWG\MISC\MKTG\MECF-XX-XX-XX-DV-XX-X-XX-MKT.SLDDRW

PROPRIETARY NOTE
THIS DOCUMENT CONTAINS CONFIDENTIAL AND PROPRIETARY INFORMATION AND ALL DESIGN, MANUFACTURING, REPRODUCTION, USE, PATENT RIGHTS AND SALES RIGHTS ARE EXPRESSLY RESERVED BY SAMTEC, INC. THIS DOCUMENT SHALL NOT BE DISCLOSED, IN WHOLE OR PART, TO ANY UNAUTHORIZED PERSON OR ENTITY NOR REPRODUCED, TRANSFERRED OR INCORPORATED IN ANY OTHER PROJECT IN ANY MANNER WITHOUT THE EXPRESS WRITTEN CONSENT OF SAMTEC, INC.

DO NOT SCALE DRAWING

SHEET SCALE: 1:0.4



520 PARK EAST BLVD, NEW ALBANY, IN 47150
PHONE: 812-944-6733 FAX: 812-948-5047
e-Mail: info@SAMTEC.com code: 55322

DESCRIPTION:
MECF .050" EDGE CARD ASSEMBLY

DWG. NO.
MECF-XX-XX-XX-DV-XX-X-XX

BY: KNOWLDEN 3/12/10 SHEET 3 OF 3