

- 1
- 2
- 3
- 4
- 5
- 6
- 7
- 8
- 9
- 10
- 11
- 12
- 13
- 14
- 15
- 16
- 17
- 18

MATERIAL

Glass-fibre reinforced polyamide based (PA) technopolymer, black colour, matte finish.

STANDARD EXECUTIONS

Black-oxide steel boss, standard reamed hole, fitting to shaft by means of a supplied grub screw with hexagon socket and cup end UNI 5929-85.

- **VC.792-GXX**: for gravity indicators.

- **VC.792-PXX**: for positive drive indicators.

Rear flange with internal crown gear wheel in acetal resin based (POM) technopolymer. Black-oxide steel screw and anchor pin.

FEATURES AND APPLICATIONS

The ergonomic design enables an effective grip. The lobed shape with no cavities prevents unhealthy residues from depositing and guarantees perfect cleaning.

Particularly suitable for applications on machines and equipment whose parts must be frequently cleaned by using water jets or steam.

INDICATOR CHOICE (TO BE ORDERED SEPARATELY)

To choose the indicator see the table below for possible assembly with indicators.

See also "Assembly instructions" for gravity indicators type G (on page 724) or positive drive indicators type P (on page 726).

ACCESSORIES ON REQUEST

- Cover CP-XX (see page 753) for use without the indicator.

SPECIAL EXECUTIONS ON REQUEST

Knob with stainless steel boss.



ELESA Original design

VC.792-GXX

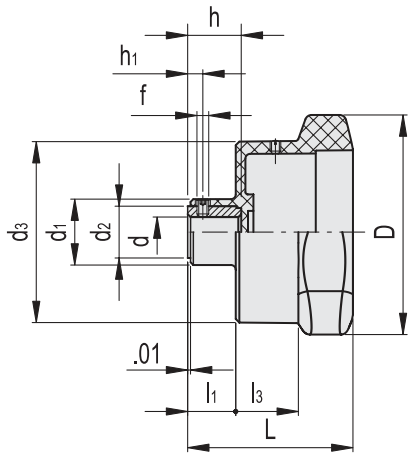

VC.792-PXX

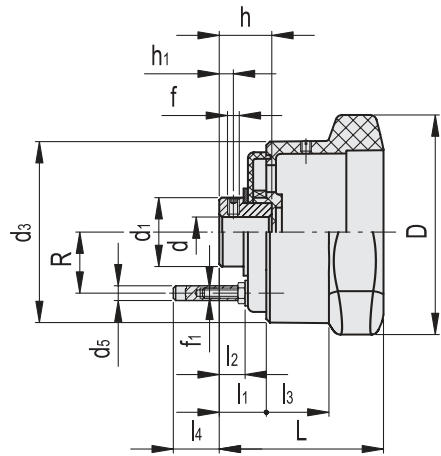

VC.792-GXX

INCH

| Code | Description | D | L | d | h | d1 | d2 | d3 | f | h1 | l1 | l3 | ⚖ | Handwheel indicator combinations |
|----------|-----------------------|------|------|-------|------|------|------|------|----|------|------|------|------|----------------------------------|
| CE930075 | VC.792/72-GXX1 A-5/16 | 2.83 | 2.05 | 0.312 | 0.67 | 0.94 | 0.71 | 2.2 | M5 | 0.24 | 0.63 | 0.75 | 0.17 | GA01 - GA11 |
| CE930081 | VC.792/98-GXX2 A-3/8 | 3.86 | 2.28 | 0.375 | 0.87 | 1.08 | 0.87 | 3.01 | M5 | 0.24 | 0.81 | 0.75 | 0.32 | GA02 - GA12 - GW12 |
| CE930085 | VC.792/98-GXX2 A-1/2 | 3.86 | 2.28 | 0.500 | 0.87 | 1.08 | 0.87 | 3.01 | M5 | 0.24 | 0.81 | 0.75 | 0.31 | GA02 - GA12 - GW12 |

VC.792-PXX

INCH

| Code | Description | D | L | d | h | d1 | d3 | d5 | f | f1 | h1 | l1 | l2 | l3 | l4 | R | ⚖ | Handwheel indicator combinations |
|----------|-----------------------|------|------|-------|------|------|------|------|----|----|------|------|------|------|------|------|------|----------------------------------|
| CE930072 | VC.792/72-PXX1 A-5/16 | 2.83 | 2.17 | 0.312 | 0.81 | 0.71 | 2.2 | 0.24 | M5 | M4 | 0.2 | 0.73 | 0.41 | 0.75 | 0.57 | 0.75 | 0.19 | PA01 - PA11 |
| CE930082 | VC.792/98-PXX2 A-3/8 | 3.86 | 2.28 | 0.375 | 0.87 | 1.18 | 3.01 | 0.24 | M5 | M4 | 0.24 | 0.79 | 0.47 | 0.75 | 0.52 | 1.12 | 0.46 | PA02 - PA12 - PW12 |

Position indicators