

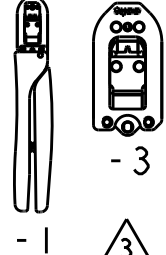



THIS DRAWING IS UNPUBLISHED. RELEASED FOR PUBLICATION 20  
 © COPYRIGHT 20 BY TYCO ELECTRONICS CORPORATION. ALL RIGHTS RESERVED.

LOC	DIST	REVISIONS			
P	LTR	DESCRIPTION	DATE	DWN	APVD
J	-	A	RELEASED	25FEB2013	JK JK

TOOL NUMBER	WIRE SIZE mm <sup>2</sup> [AWG]	INSULATION DIAMETER mm [in.]	INSUL. ADJ.	STRIP LENGTH mm [in.]	CRIMP HEIGHT mm [in.]	CONTACT PART NUMBERS 		CONTACT DESCRIP.	APPLIC. SPECIF.
						LOOSE PIECE	STRIP FORM		
 -1  -3	 0.21 - 0.38 [24-22] 0.51-0.53 [20]	 1.5-2.5 [.059 - .098]	 YES	 1.5-2.5 [.059-.098]	 0.75±0.05 [.0295±.002] 0.90±0.05 [.0354±.002]	 1827395-[ ]		Grace Inertia Conn 3.3 Contact	114-5372

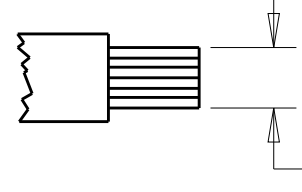
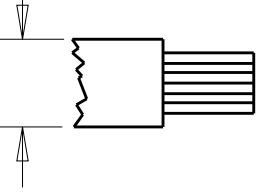
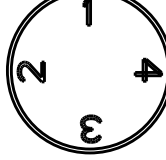
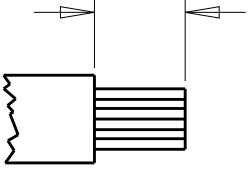
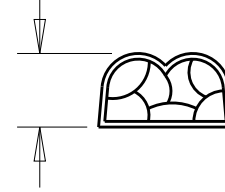
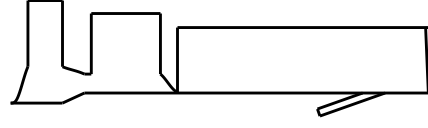
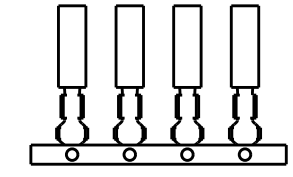
 LIST OF APPLIED CONTACT PART NUMBERS MAY NOT BE COMPLETE AND IS SUBJECT TO CHANGE. FOR CURRENT INFORMATION ON TERMINAL PART NUMBERS, CONTACT THE TOOLING ASSISTANCE CENTER : 1-800-722-1111.

 -1 IS A CERTICRIMP II HAND TOOL ASSEMBLY. -3 IS A CERTICRIMP II HEAD SUB-ASSEMBLY.

2. TE, CERTI-CRIMP are trademarks.

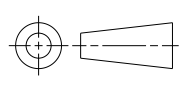
<small>THIS DRAWING IS A CONTROLLED DOCUMENT FOR TYCO ELECTRONICS CORPORATION. IT IS SUBJECT TO CHANGE AND THE CONTROLLING ENGINEERING ORGANIZATION SHOULD BE CONTACTED FOR THE LATEST REVISION.</small>		DWN JK 25OCT2013 CHK JK 25OCT2013 APVD J.KOGA 25OCT2013	 TE Connectivity Kawasaki, Japan
DIMENSIONS: mm 	TOLERANCES UNLESS OTHERWISE SPECIFIED: 0 PLC ± 1 PLC ± 2 PLC ± 3 PLC ± 4 PLC ± ANGLES ± FINISH	PRODUCT SPEC - APPLICATION SPEC - WEIGHT -	NAME CERTI-CRIMP II TOOL DATA SHEET GIC 3.3 CONTACT (24-20) SIZE A2 CAGE CODE 00779 DATA SHEET NO DS-1762390 RESTRICTED TO -
MATERIAL -		DATA SHEET	SCALE - SHEET 1 OF 1 REV A