

THIS DRAWING IS UNPUBLISHED. RELEASED FOR PUBLICATION
 © COPYRIGHT BY TYCO ELECTRONICS CORPORATION. ALL INTERNATIONAL RIGHTS RESERVED.

LOC	DIST	REVISIONS			
P	LTR	DESCRIPTION	DATE	DWN	APVD
AF	50				
	C1	REVISED PER ECR-10-001322	23JAN10	HMR	GP
	D	ECR-13-004361	05AUG13	XJ	DZ

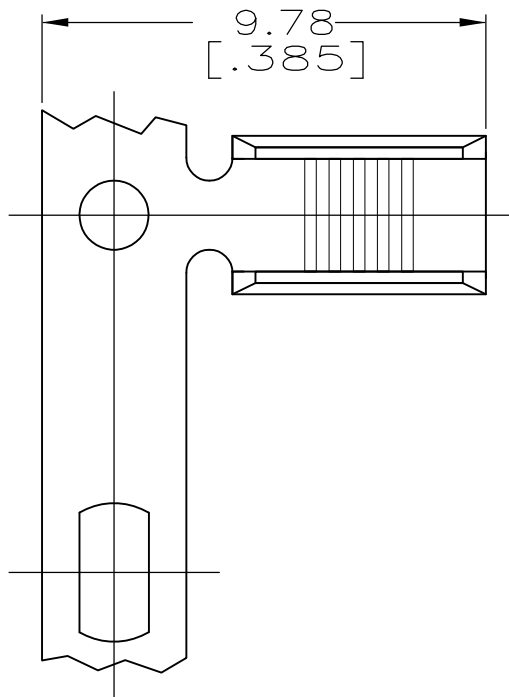

- 1 CONTINUOUS STRIP ON REELS.
- 2 CRIMP WIDTH = .110 F TYPE (AMPLIVAR THRU)
 CRIMP HEIGHT (±.002) = (TOTAL CMA + 11,500) / 194,200
 GENERAL APPLICATION GUIDELINES MUST BE FOLLOWED
 AS SPECIFIED IN CATALOG #82221
 FOR APPLICATOR INFORMATION CALL: 1-800-722-1111
 FOR PRODUCT INFORMATION CALL: 1-800-522-6752
- 3 TIN 112-16-3 0.00203 [.000080] MIN THK

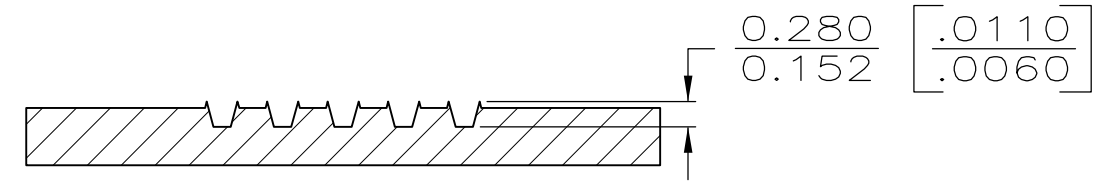
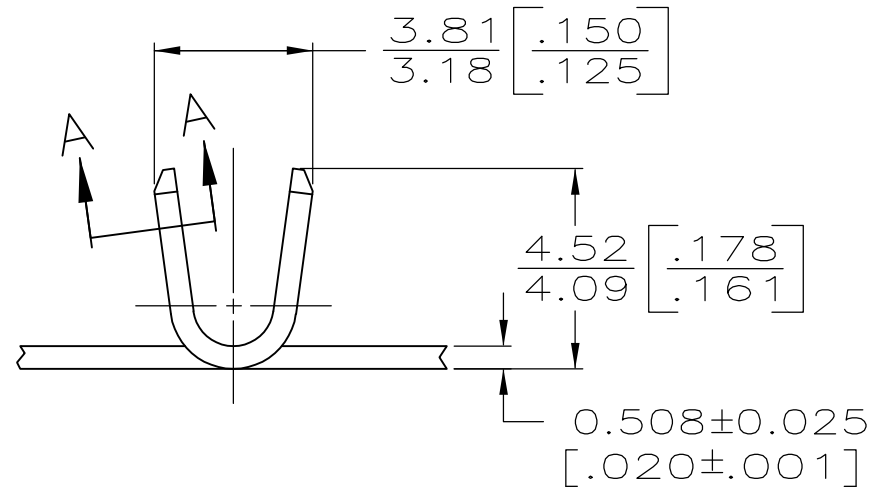
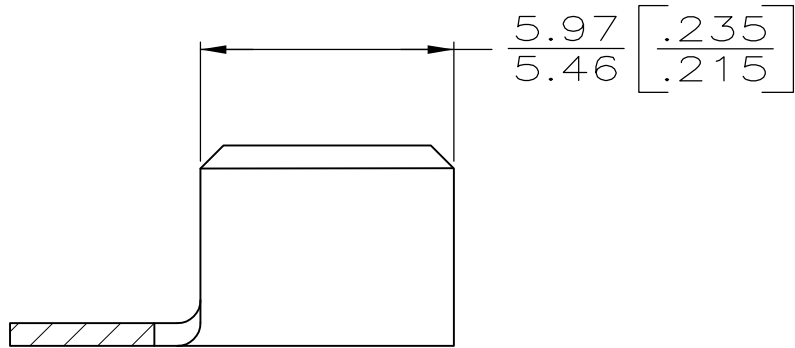

SECTION A-A
 SCALE 15:1
 ROTATED

2 2000-5400 CMA	3 63564-3
	63564-1
WIRE RANGE	PART NO

METRIC

THIS DRAWING IS A CONTROLLED DOCUMENT.		DWN MICHAEL S. FEHER 12/20/89	Tyco Electronics Corporation Harrisburg, PA 17105-3608	
DIMENSIONS: mm [INCHES]	TOLERANCES UNLESS OTHERWISE SPECIFIED:	CHK P. FORTNEY 12/21/89	NAME SPLICE, AMPLIVAR, 5 SERRATIONS	
	0 PLC ± -	APVD T.L. SHUTTER 1/2/90	PRODUCT SPEC	
	1 PLC ± -	APPLICATION SPEC	114-2009	RESTRICTED TO
	2 PLC ± -	WEIGHT	-	
	3 PLC ± 0.25 [.010]	CUSTOMER DRAWING		
	4 PLC ± -	SCALE	6:1	SHEET
	ANGLES ± -	SIZE	A3	CAGE CODE
MATERIAL	FINISH	DRAWING NO	C-63564	REV
BRASS	-	SCALE	6:1	1 OF 1
		RESTRICTED TO		D