

Brushless gearmotor

Data sheet

80 181 001
PWM - ratio 5

Series
801810 TNI20

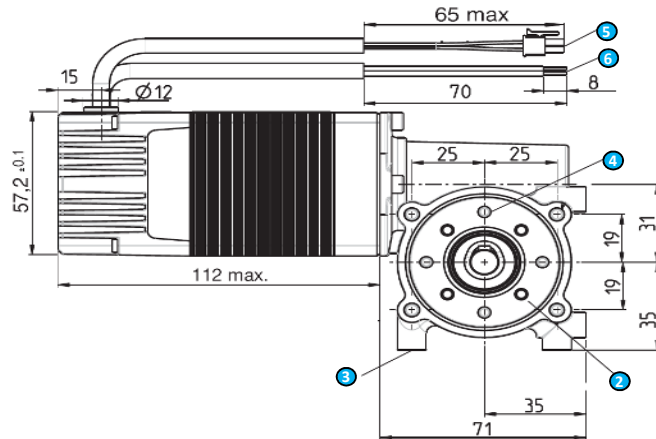
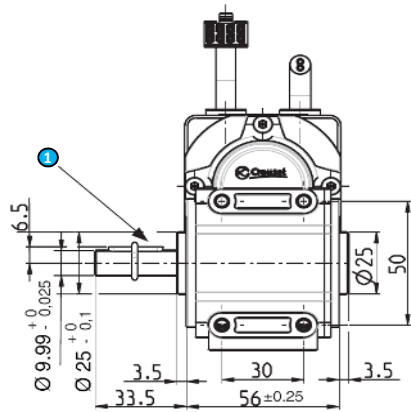

- 1 Parallel key 4 x 4 x 20 DIN6885A
2 4 x M4, depth 8 over diameter 36 mm

- 3 8 x M5, depth 8
4 4 x holes D. 3,8 mm, depth 10 over diameter 40 mm

- 5 Input - Output cable with Molex connector - 500 mm +/- 20
6 Power supply cable - 500 mm +/- 20

General characteristics

Power supply		
Direct current voltage supply		$\frac{V}{A}$
Nominal voltage range	Vdc	18 -> 32
Max. current	A	6

Gearmotor type		801810 TNI20
Motor type		80 180 001
Gearbox type		81 041 0
Ratio		5
Shaft output		Left
Max. permissible continuous torque	Nm	10
Max. backlash	°	0,5

Motor characteristics (1)		24 Vdc	
At no load			
Max. output speed	rpm	840	
Current at the max output speed (6)	A	0,39	
Standby current	A		
At nominal			
Speed	rpm	650	+/-15%
Torque (2)	Nm	0,6	
Output power	W	43	+/-15%
Current	A	4,8	
Efficiency	%	37	
At max. output power			
Speed	rpm	600	
Torque	Nm	0,8	
Output power	W	49	
Current	A	6,0	
Efficiency	%	34	
At peak torque			
Speed	rpm	600	
Torque	Nm	0,8	
Output power	W	49	
Current	A	6,0	
Others			
Weight	kg	2,04	
Noise level	dBA	45	

Connecting	
Input - Output cable	With Molex connector ref: 43025-0800
Output cable, UL style 2464 80°C 300V	- 8 wires AWG24
Input: ON/OFF	1 - Green
Input: Direction	2 - Yellow
Input: Torque limit	3 - Blue
Input: Speed	4 - Orange
0V	5 - Black
Output: Pulse	6 - Brown
Output: Torque limit reached	7 - Purple
Output: Direction	8 - Red
Power supply cable	
Cable UL style 2464 80°C 300V	- 2 wires AWG20 - 500 mm
+ 18Vcc -> + 32 Vdc	Brown
0V	Black

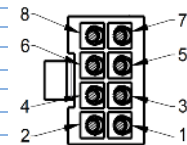

Drive	
Type	TNI20
Built-in drive	$\frac{V}{A}$
Internal encoder	12 pulses per turn
Control	
Speed	PWM
Torque	PWM
4 quadrants - low braking	$\frac{V}{A}$
4 quadrants with regenerative energy	$\frac{V}{A}$
"Trapezoidal" type	$\frac{V}{A}$
Security	
Short-circuit of outputs	$\frac{V}{A}$
Input inverted	$\frac{V}{A}$
Low voltage	Vdc < 14
Short high voltage	Vdc > 36
Stop at max internal drive temperature (2)	°C 110
Drive temperature allowing to restart	°C 90

Generic parameters			
Output shaft with ball bearings		$\frac{V}{A}$	
Max. Radial force (12mm from front face)	N	150	
Max. axial force(4)	N	100	
Temperature range	CEI60068-2-1/2	°C	-30 -> +70
Storage temperature		°C	-40 -> +80
Dielectric	1min 2mA 50Hz	CEI60335	Vac 1 000
Motor insulation	CEI60085	class	E
Salt spray	CEI60068-2-58	severity	48h
Degree of protection (output shaft not included)	CEI60529	IP	54
EMC			
Electrostatic Discharge	CEI61000-4-2	level	3
Radio frequency	CEI61000-4-3	level	3
Electrical fast transient / burst test	CEI61000-4-4	level	3
Surge test	CEI61000-4-5	level	1
Conducted disturbance	CEI61000-4-6	level	3
Radiated emission	EN55022	class	B
Approvals			
ROHS	2011/65/UE	$\frac{V}{A}$	
EC	2014/30/UE	$\frac{V}{A}$	

Notes
Values without tolerance are average production values.
Motor not protected in case of reversed power voltage
(1) Cold motor, 20 °C ambient temperature, full speed
(2) Max torque for continuous operation at 20 °C, decrease this value for higher ambient temperature
(4) Pinion or pulley fitting are done at the Crouzet factory, before final assembly.
(6) Value without gearbox. With gearbox, the value increases and varies depending on grease temperature.

Specifications subject to change without notice. Updated 21/11/2016

Drive electrical datas

Absolute maximum ratings				
Parameters				
Max. voltage supply "Vcc"	Vdc		36	
Max. current "Icc max"	A		6	
Max. voltage on inputs "Vin max"	Vdc		36	
Max. voltage on outputs "Vout max"	Vdc		36	
Max. output current "Iout max"	mA		50	
Running datas				
Parameters				
Voltage supply "Vcc"	Vdc	Min	Typical	Max
		18	24	32
Current "Icc"	A	-	4	6
Standby power "Wo"	W	-	2	-
Speed setting	rpm	0 / 24	-	840
Torque setting	Nm	0,3	-	0,8

Input datas				
Parameters				
Impedance - Input 1, 2 (On/Off - Direction)	kΩ	Min	Typical	Max
		-	59	-
Impedance - Input 3 (torque)	kΩ	-	16,4	-
Impedance - Input 4 (speed)	kΩ	-	19	-
Low level - Input 1, 2	Vdc	0	-	2
High level - Input 1, 2	Vdc	4	-	36
Low level - Input 3, 4	Vdc	0	-	2,5
High level - Input 3, 4	Vdc	11,5	-	36
PWM frequency	Hz	150	-	1000
Output datas				
Parameters				
Low level Outputs	Vdc	Min	Typical	Max
with "pull down resistor" = 4,7KΩ and Vcc = 24 V		0	-	0,2
High level Outputs	Vdc	Vcc - 0,5	-	Vcc
with "pull down resistor" = 4,7KΩ and Vcc = 24 V = voltage supply added from eventual rejective voltage				
Notes				
Outputs are destroyed if they are connected to zero ground or to a capacitive load				

Speed-torque and current-torque curves

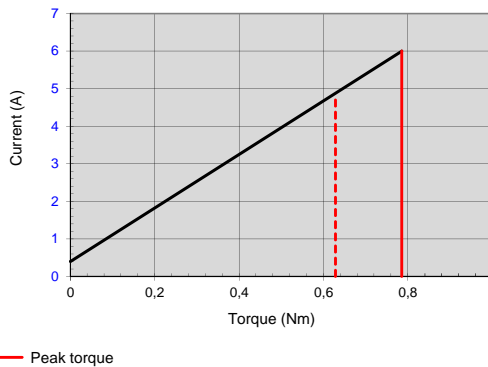
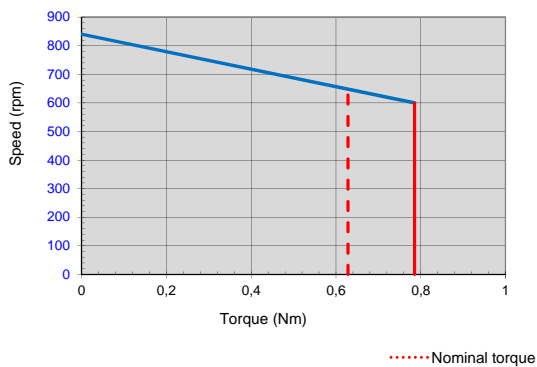

Wiring

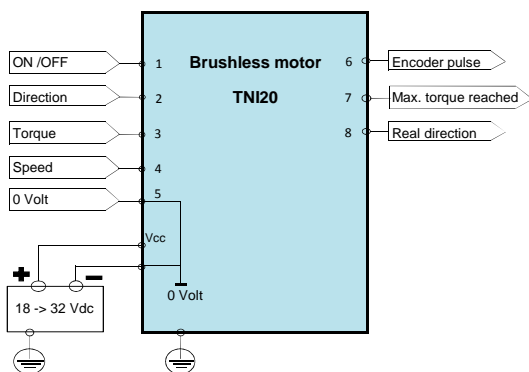

Output equivalent circuit

Outputs

Add a pull down resistor

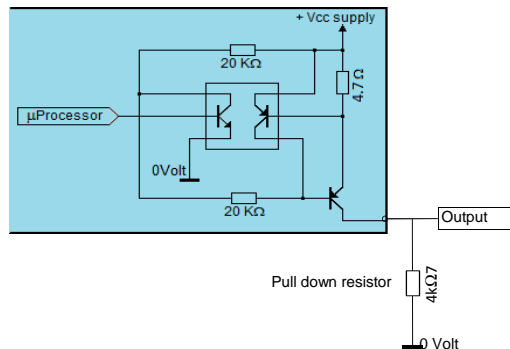

Input equivalent circuits

Inputs 1; 2: ON/OFF and Direction

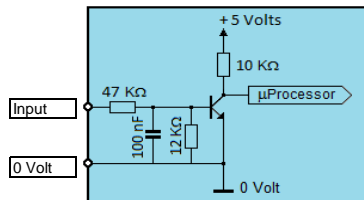

Input 3: Torque

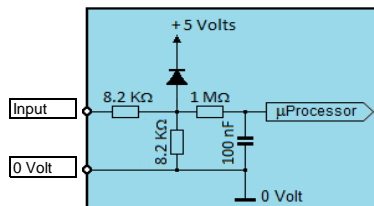

Input 4: Speed (if 0/10 V drive)

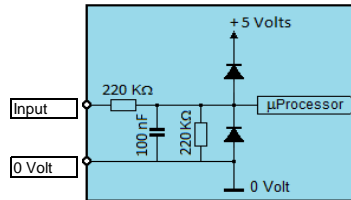

Input 4: Speed (if PWM drive)

