

REVISIONS

P	LTR	DESCRIPTION	DATE	DWN	APVD
	A	REVISED AS PER ECR-15-005925	21APR2015	RS	JL

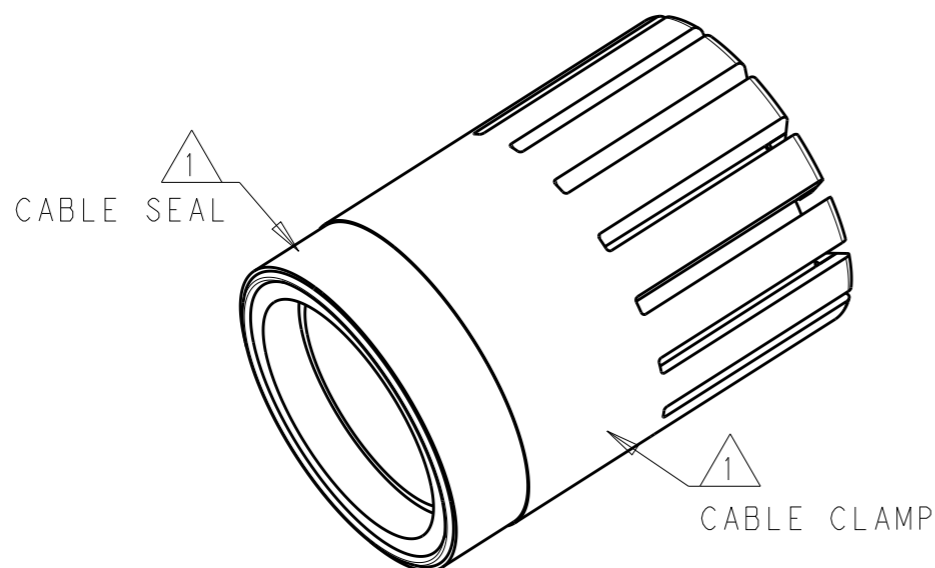

NOTES:

- 1 MATERIALS:
 CABLE SEAL-THERMOPLASTIC ELASTOMER (TPE),
 COLOR BLACK
 CABLE CLAMP-GLASS FILLED PBT,
 COLOR BLACK
- 2. MUST COMPLY WITH DIRECTIVE 2002/95/EC (ROHS)
- 3. THIS PRODUCT HAS NOT COMPLETED VALIDATION TESTING

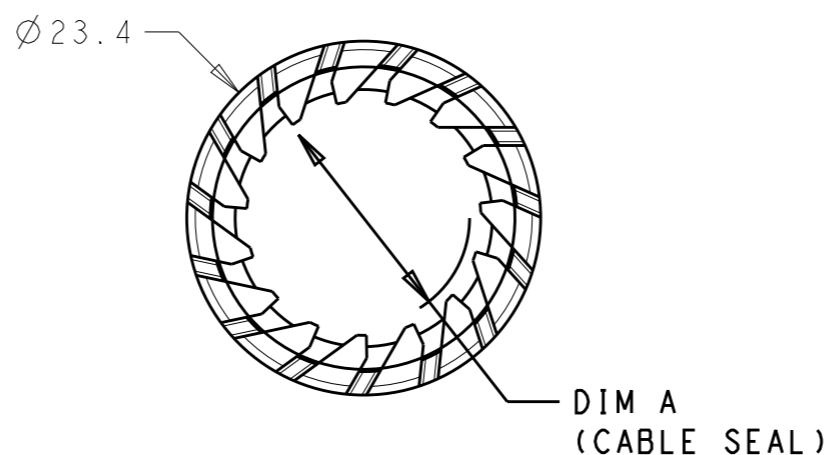
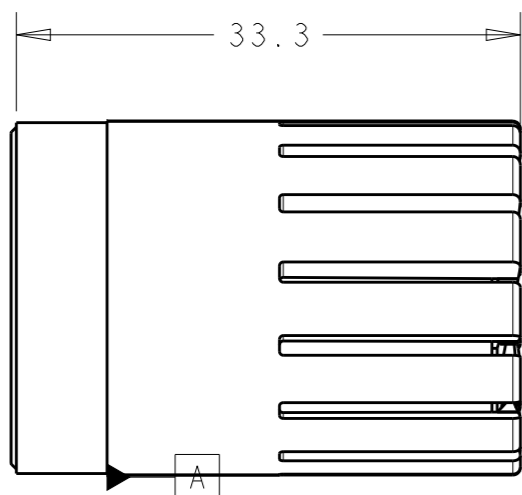

14-17	17.0	2213351-2
11-14	14.0	2213351-1
CABLE DIA	DIA "A"	PART NO.

THIS DRAWING IS A CONTROLLED DOCUMENT.

DIMENSIONS:
mm

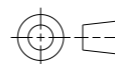

TOLERANCES UNLESS OTHERWISE SPECIFIED:

0 PLC	±-
1 PLC	±0.2
2 PLC	±0.13
3 PLC	±-
4 PLC	±-
ANGLES	±-

MATERIAL
NOTE 1

FINISH

-

DWN J. SHAFFER 13NOV2013

CHK M. LUKSIC 13NOV2013

APVD M. LUKSIC 13NOV2013

PRODUCT SPEC

108-133014

APPLICATION SPEC

114-32111

WEIGHT

-

Customer Drawing

STE TE Connectivity

NAME
 CABLE CLAMP/SEAL ASSY, 5/6/7
 POSN, NECTOR M-LINE, SEALED

SIZE	CAGE CODE	DRAWING NO	RESTRICTED TO
A3	-	©-2213351	-

SCALE 1:1 SHEET 1 OF 1 REV A