

**FEATURES:**

- 0.5 MICRON CMOS Technology
- Typical  $t_{sk(o)}$  (Output Skew) < 250ps
- ESD > 2000V per MIL-STD-883, Method 3015; > 200V using machine model (C = 200pF, R = 0)
- $V_{CC} = 3.3V \pm 0.3V$ , Normal Range
- $V_{CC} = 2.7V$  to  $3.6V$ , Extended Range
- $V_{CC} = 2.5V \pm 0.2V$
- CMOS power levels (0.4 $\mu$  W typ. static)
- Rail-to-Rail output swing for increased noise margin
- Available in TSSOP package

**DRIVE FEATURES:**

- Balanced Output Drivers:  $\pm 12mA$
- Low switching noise

**APPLICATIONS:**

- 3.3V high speed systems
- 3.3V and lower voltage computing systems

**DESCRIPTION:**

This 16-bit buffer/driver is built using advanced dual metal CMOS technology. The ALVCH162244 is designed specifically to improve the performance and density of 3-state memory address drivers, clock drivers, and bus-oriented receivers and transmitters. The device can be used as four 4-bit buffers, two 8-bit buffers, or one 16-bit buffer. It provides true outputs and symmetrical active-low output-enable ( $\overline{OE}$ ) inputs.

The ALVCH162244 has series resistors in the device output structure which will significantly reduce line noise when used with light loads. This driver has been designed to drive  $\pm 12mA$  at the designated threshold levels.

The ALVCH162244 has "bus-hold" which retains the inputs' last state whenever the input bus goes to a high impedance. This prevents floating inputs and eliminates the need for pull-up/down resistors.

**FUNCTIONAL BLOCK DIAGRAM**

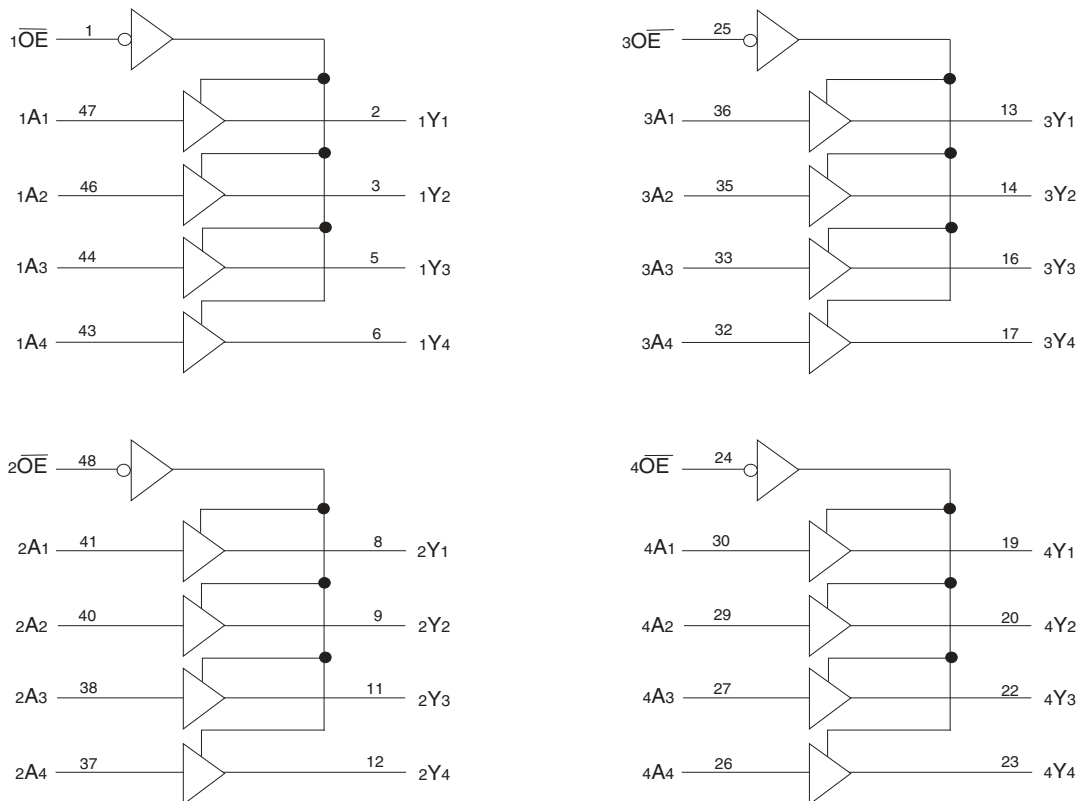

IDT and the IDT logo are registered trademarks of Integrated Device Technology, Inc.

## PIN CONFIGURATION

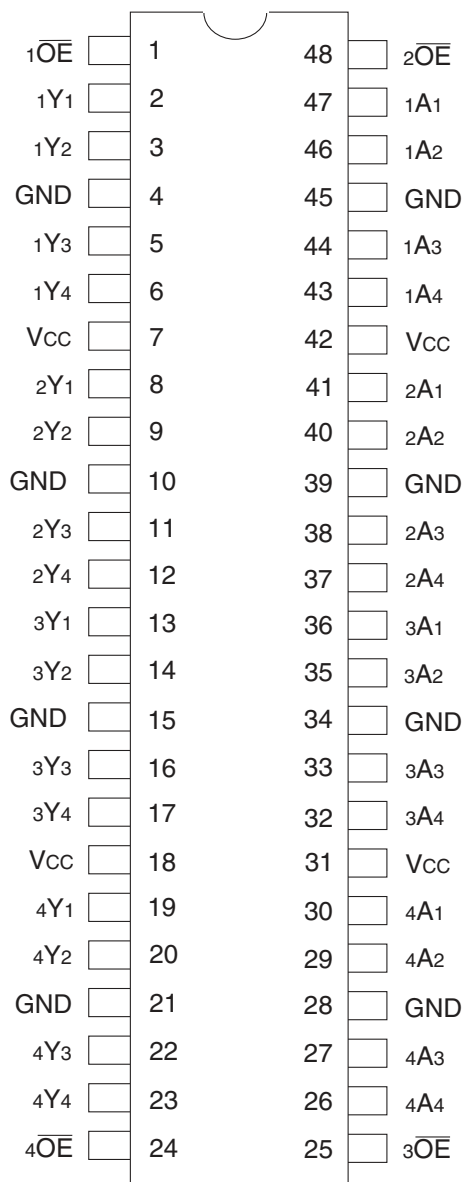

TSSOP  
TOP VIEW

## ABSOLUTE MAXIMUM RATINGS<sup>(1)</sup>

| Symbol                             | Description   | Max             | Unit |
|------------------------------------|---|-----------------|------|
| VTERM <sup>(2)</sup>               | Terminal Voltage with Respect to GND  | -0.5 to +4.6    | V    |
| VTERM <sup>(3)</sup>               | Terminal Voltage with Respect to GND  | -0.5 to VCC+0.5 | V    |
| TSTG                               | Storage Temperature   | -65 to +150     | °C   |
| IOUT                               | DC Output Current   | -50 to +50      | mA   |
| I <sub>IK</sub>                    | Continuous Clamp Current,<br>V <sub>I</sub> < 0 or V <sub>I</sub> > V <sub>CC</sub> | ±50             | mA   |
| I <sub>OK</sub>                    | Continuous Clamp Current, V <sub>O</sub> < 0  | -50             | mA   |
| I <sub>CC</sub><br>I <sub>SS</sub> | Continuous Current through each<br>V <sub>CC</sub> or GND                           | ±100            | mA   |

### NOTES:

- Stresses greater than those listed under ABSOLUTE MAXIMUM RATINGS may cause permanent damage to the device. This is a stress rating only and functional operation of the device at these or any other conditions above those indicated in the operational sections of this specification is not implied. Exposure to absolute maximum rating conditions for extended periods may affect reliability.
- V<sub>CC</sub> terminals.
- All terminals except V<sub>CC</sub>.

## CAPACITANCE (T<sub>A</sub> = +25°C, F = 1.0MHz)

| Symbol           | Parameter <sup>(1)</sup> | Conditions            | Typ. | Max. | Unit |
|------------------|--------------------------|-----------------------|------|------|------|
| C <sub>IN</sub>  | Input Capacitance        | V <sub>IN</sub> = 0V  | 5    | 7    | pF   |
| C <sub>OUT</sub> | Output Capacitance       | V <sub>OUT</sub> = 0V | 7    | 9    | pF   |
| C <sub>I/O</sub> | I/O Port Capacitance     | V <sub>IN</sub> = 0V  | 7    | 9    | pF   |

### NOTE:

- As applicable to the device type.

## PIN DESCRIPTION

| Pin Names         | Description                               |
|-------------------|---|
| x $\overline{OE}$ | 3-State Output Enable Inputs (Active LOW) |
| xAx               | Data Inputs <sup>(1)</sup>                |
| xYx               | 3-State Outputs                           |

### NOTE:

- These pins have "Bus-Hold". All other pins are standard inputs, outputs, or I/Os.

## FUNCTION TABLE (EACH 4-BIT BUFFER)<sup>(1)</sup>

| Inputs            |     | Outputs |
|-------------------|-----|---------|
| x $\overline{OE}$ | xAx | xYx     |
| L                 | H   | H       |
| L                 | L   | L       |
| H                 | X   | Z       |

### NOTE:

- H = HIGH Voltage Level  
X = Don't Care  
L = LOW Voltage Level  
Z = High-Impedance

## DC ELECTRICAL CHARACTERISTICS OVER OPERATING RANGE

Following Conditions Apply Unless Otherwise Specified:

Operating Condition:  $T_A = -40^{\circ}\text{C}$  to  $+85^{\circ}\text{C}$

| Symbol   | Parameter  | Test Conditions   |                                  | Min. | Typ. <sup>(1)</sup> | Max. | Unit |
|--|--|---|----------------------------------|------|---------------------|------|------|
| V <sub>IH</sub>  | Input HIGH Voltage Level                               | V <sub>CC</sub> = 2.3V to 2.7V  |                                  | 1.7  | —                   | —    | V    |
|  |  | V <sub>CC</sub> = 2.7V to 3.6V  |                                  | 2    | —                   | —    |      |
| V <sub>IL</sub>  | Input LOW Voltage Level                                | V <sub>CC</sub> = 2.3V to 2.7V  |                                  | —    | —                   | 0.7  | V    |
|  |  | V <sub>CC</sub> = 2.7V to 3.6V  |                                  | —    | —                   | 0.8  |      |
| I <sub>IH</sub>  | Input HIGH Current                                     | V <sub>CC</sub> = 3.6V  | V <sub>I</sub> = V <sub>CC</sub> | —    | —                   | ±5   | μA   |
| I <sub>IL</sub>  | Input LOW Current                                      | V <sub>CC</sub> = 3.6V  | V <sub>I</sub> = GND             | —    | —                   | ±5   | μA   |
| I <sub>OZH</sub><br>I <sub>OZL</sub>                     | High Impedance Output Current<br>(3-State Output pins) | V <sub>CC</sub> = 3.6V  |                                  | —    | —                   | ±10  | μA   |
|  |  | V <sub>O</sub> = GND  |                                  | —    | —                   | ±10  |      |
| V <sub>IK</sub>  | Clamp Diode Voltage                                    | V <sub>CC</sub> = 2.3V, I <sub>IN</sub> = -18mA                             |                                  | —    | -0.7                | -1.2 | V    |
| V <sub>H</sub>   | Input Hysteresis                                       | V <sub>CC</sub> = 3.3V  |                                  | —    | 100                 | —    | mV   |
| I <sub>CC1</sub><br>I <sub>CC2</sub><br>I <sub>CC3</sub> | Quiescent Power Supply Current                         | V <sub>CC</sub> = 3.6V<br>V <sub>IN</sub> = GND or V <sub>CC</sub>          |                                  | —    | 0.1                 | 40   | μA   |
| ΔI <sub>CC</sub>   | Quiescent Power Supply Current Variation               | One input at V <sub>CC</sub> - 0.6V, other inputs at V <sub>CC</sub> or GND |                                  | —    | —                   | 750  | μA   |

NOTE:

1. Typical values are at V<sub>CC</sub> = 3.3V, +25°C ambient.

## BUS-HOLD CHARACTERISTICS

| Symbol                                 | Parameter <sup>(1)</sup>         | Test Conditions        |  | Min.                       | Typ. <sup>(2)</sup> | Max. | Unit |    |
|--|----------------------------------|------------------------|--|----------------------------|---------------------|------|------|----|
| I <sub>BHH</sub><br>I <sub>BHL</sub>   | Bus-Hold Input Sustain Current   | V <sub>CC</sub> = 3V   |  | —                          | —                   | —    | μA   |    |
|  |                                  | V <sub>I</sub> = 0.8V  |  | -75                        | —                   | —    |      |    |
| I <sub>BHH</sub><br>I <sub>BHL</sub>   | Bus-Hold Input Sustain Current   | V <sub>CC</sub> = 2.3V |  | —                          | —                   | —    | μA   |    |
|  |                                  | V <sub>I</sub> = 0.7V  |  | -45                        | —                   | —    |      |    |
| I <sub>BHHO</sub><br>I <sub>BHLO</sub> | Bus-Hold Input Overdrive Current | V <sub>CC</sub> = 3.6V |  | V <sub>I</sub> = 0 to 3.6V |                     | —    | ±500 | μA |

NOTES:

1. Pins with Bus-Hold are identified in the pin description.
2. Typical values are at V<sub>CC</sub> = 3.3V, +25°C ambient.

## OUTPUT DRIVE CHARACTERISTICS

| Symbol                  | Parameter           | Test Conditions <sup>(1)</sup> |                          | Min.                  | Max. | Unit |
|-------------------------|---------------------|--------------------------------|--------------------------|-----------------------|------|------|
| VOH                     | Output HIGH Voltage | V <sub>CC</sub> = 2.3V to 3.6V | I <sub>OH</sub> = -0.1mA | V <sub>CC</sub> - 0.2 | —    | V    |
|                         |                     | V <sub>CC</sub> = 2.3V         | I <sub>OH</sub> = -4mA   | 1.9                   | —    |      |
|                         |                     |                                | I <sub>OH</sub> = -6mA   | 1.7                   | —    |      |
|                         |                     | V <sub>CC</sub> = 2.7V         | I <sub>OH</sub> = -4mA   | 2.2                   | —    |      |
|                         |                     |                                | I <sub>OH</sub> = -8mA   | 2                     | —    |      |
|                         |                     | V <sub>CC</sub> = 3V           | I <sub>OH</sub> = -6mA   | 2.4                   | —    |      |
| I <sub>OH</sub> = -12mA | 2                   |                                | —                        |                       |      |      |
| VOL                     | Output LOW Voltage  | V <sub>CC</sub> = 2.3V to 3.6V | I <sub>OL</sub> = 0.1mA  | —                     | 0.2  | V    |
|                         |                     | V <sub>CC</sub> = 2.3V         | I <sub>OL</sub> = 4mA    | —                     | 0.4  |      |
|                         |                     |                                | I <sub>OL</sub> = 6mA    | —                     | 0.55 |      |
|                         |                     | V <sub>CC</sub> = 2.7V         | I <sub>OL</sub> = 4mA    | —                     | 0.4  |      |
|                         |                     |                                | I <sub>OL</sub> = 8mA    | —                     | 0.6  |      |
|                         |                     | V <sub>CC</sub> = 3V           | I <sub>OL</sub> = 6mA    | —                     | 0.55 |      |
| I <sub>OL</sub> = 12mA  | —                   |                                | 0.8                      |                       |      |      |

NOTE:  
1. V<sub>IH</sub> and V<sub>IL</sub> must be within the min. or max. range shown in the DC ELECTRICAL CHARACTERISTICS OVER OPERATING RANGE table for the appropriate V<sub>CC</sub> range.  
T<sub>A</sub> = -40°C to +85°C.

## OPERATING CHARACTERISTICS, T<sub>A</sub> = 25°C

| Symbol | Parameter                                      | Test Conditions                 | V <sub>CC</sub> = 2.5V ± 0.2V | V <sub>CC</sub> = 3.3V ± 0.3V | Unit |
|--------|--|---------------------------------|-------------------------------|-------------------------------|------|
|        |  |                                 | Typical                       | Typical                       |      |
| CPD    | Power Dissipation Capacitance Outputs enabled  | C <sub>L</sub> = 0pF, f = 10MHz | 16                            | 19                            | pF   |
| CPD    | Power Dissipation Capacitance Outputs disabled |                                 | 4                             | 5                             |      |

## SWITCHING CHARACTERISTICS<sup>(1)</sup>

| Symbol           | Parameter                  | V <sub>CC</sub> = 2.5V ± 0.2V |      | V <sub>CC</sub> = 2.7V |      | V <sub>CC</sub> = 3.3V ± 0.3V |      | Unit |
|------------------|----------------------------|-------------------------------|------|------------------------|------|-------------------------------|------|------|
|                  |                            | Min.                          | Max. | Min.                   | Max. | Min.                          | Max. |      |
| t <sub>PLH</sub> | Propagation Delay          | 1                             | 4.9  | —                      | 4.7  | 1                             | 4.2  | ns   |
| t <sub>PHL</sub> | xAx to xYx                 |                               |      |                        |      |                               |      |      |
| t <sub>PZH</sub> | Output Enable Time         | 1                             | 6.8  | —                      | 6.7  | 1                             | 5.6  | ns   |
| t <sub>PZL</sub> | xOE to xYx                 |                               |      |                        |      |                               |      |      |
| t <sub>PHZ</sub> | Output Disable Time        | 1                             | 6.3  | —                      | 5.7  | 1                             | 5.5  | ns   |
| t <sub>PLZ</sub> | xOE to xYx                 |                               |      |                        |      |                               |      |      |
| tsk(o)           | Output Skew <sup>(2)</sup> | —                             | —    | —                      | —    | —                             | 500  | ps   |

NOTES:  
1. See TEST CIRCUITS AND WAVEFORMS. T<sub>A</sub> = -40°C to +85°C.  
2. Skew between any two outputs of the same package and switching in the same direction.

## TEST CIRCUITS AND WAVEFORMS

### TEST CONDITIONS

| Symbol            | V <sub>CC</sub> <sup>(1)</sup> =3.3V±0.3V | V <sub>CC</sub> <sup>(1)</sup> =2.7V | V <sub>CC</sub> <sup>(2)</sup> =2.5V±0.2V | Unit |
|-------------------|---|--------------------------------------|---|------|
| V <sub>LOAD</sub> | 6   | 6                                    | 2 x V <sub>CC</sub>                       | V    |
| V <sub>IH</sub>   | 2.7                                       | 2.7                                  | V <sub>CC</sub>                           | V    |
| V <sub>T</sub>    | 1.5                                       | 1.5                                  | V <sub>CC</sub> / 2                       | V    |
| V <sub>LZ</sub>   | 300                                       | 300                                  | 150                                       | mV   |
| V <sub>HZ</sub>   | 300                                       | 300                                  | 150                                       | mV   |
| C <sub>L</sub>    | 50  | 50                                   | 30  | pF   |

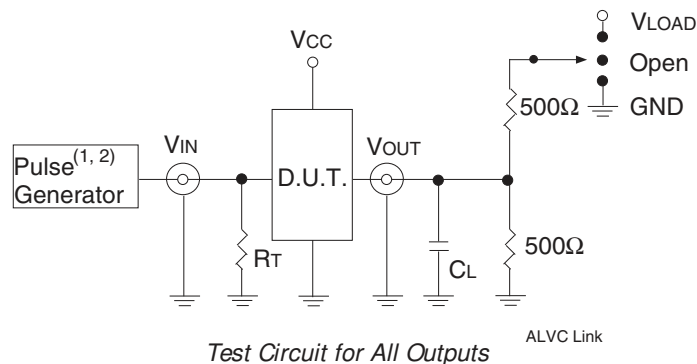

#### DEFINITIONS:

C<sub>L</sub> = Load capacitance: includes jig and probe capacitance.  
R<sub>T</sub> = Termination resistance: should be equal to Z<sub>OUT</sub> of the Pulse Generator.

#### NOTES:

1. Pulse Generator for All Pulses: Rate ≤ 1.0MHz; t<sub>r</sub> ≤ 2.5ns; t<sub>r</sub> ≤ 2.5ns.
2. Pulse Generator for All Pulses: Rate ≤ 1.0MHz; t<sub>r</sub> ≤ 2ns; t<sub>r</sub> ≤ 2ns.

### SWITCH POSITION

| Test                                    | Switch            |
|---|-------------------|
| Open Drain<br>Disable Low<br>Enable Low | V <sub>LOAD</sub> |
| Disable High<br>Enable High             | GND               |
| All Other Tests                         | Open              |

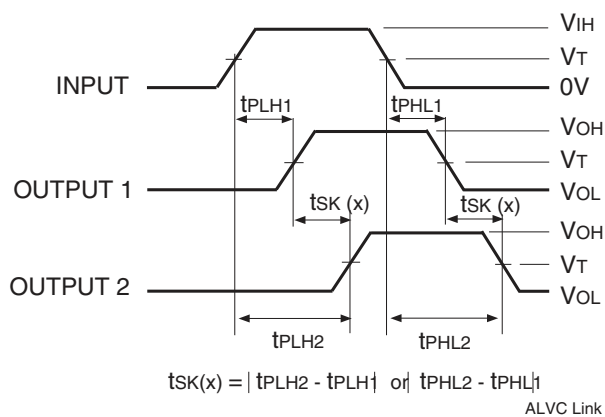

$$t_{SK}(x) = |t_{PLH2} - t_{PLH1}| \text{ or } |t_{PHL2} - t_{PHL1}|$$

#### Output Skew - t<sub>SK</sub>(x)

#### NOTES:

1. For t<sub>SK</sub>(o) OUTPUT1 and OUTPUT2 are any two outputs.
2. For t<sub>SK</sub>(b) OUTPUT1 and OUTPUT2 are in the same bank.

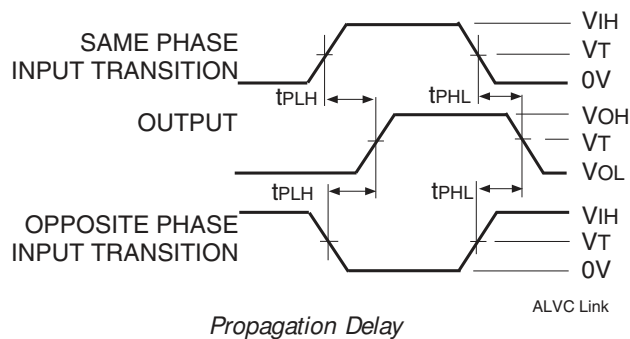

#### Propagation Delay

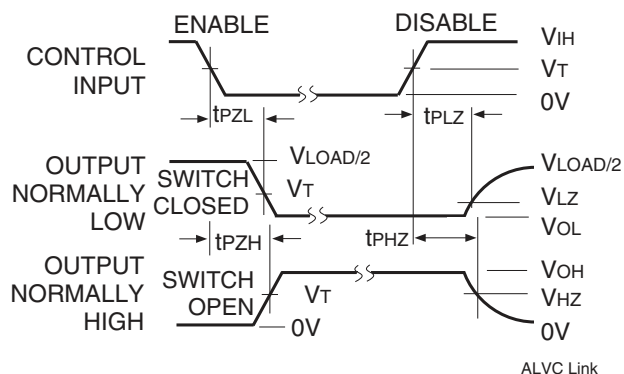

#### Enable and Disable Times

#### NOTE:

1. Diagram shown for input Control Enable-LOW and input Control Disable-HIGH.

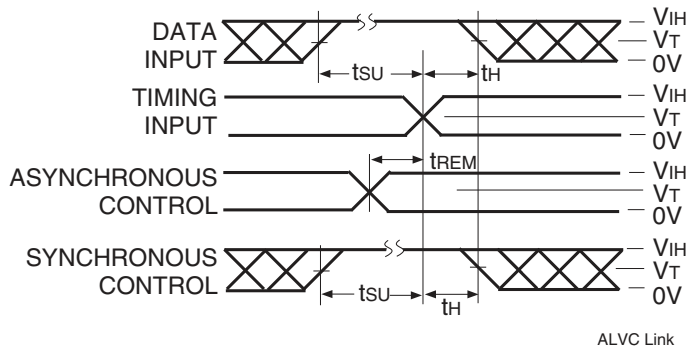

#### Set-up, Hold, and Release Times

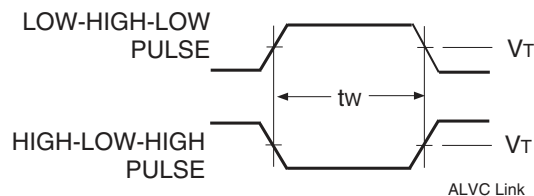

#### Pulse Width

## ORDERING INFORMATION

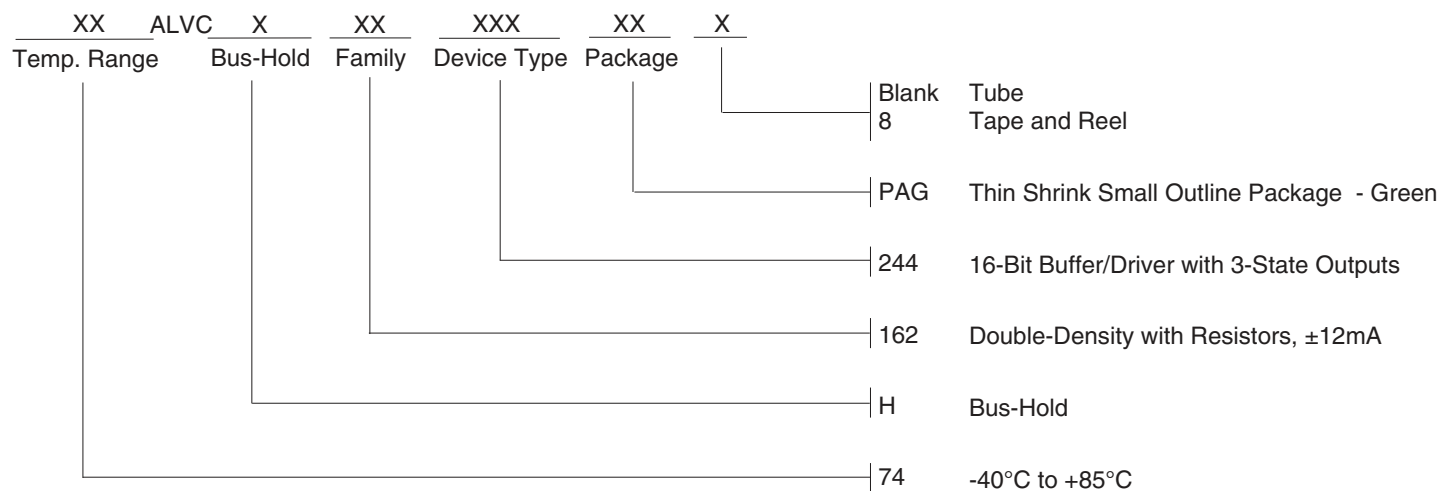

## IMPORTANT NOTICE AND DISCLAIMER

RENESAS ELECTRONICS CORPORATION AND ITS SUBSIDIARIES (“RENESAS”) PROVIDES TECHNICAL SPECIFICATIONS AND RELIABILITY DATA (INCLUDING DATASHEETS), DESIGN RESOURCES (INCLUDING REFERENCE DESIGNS), APPLICATION OR OTHER DESIGN ADVICE, WEB TOOLS, SAFETY INFORMATION, AND OTHER RESOURCES “AS IS” AND WITH ALL FAULTS, AND DISCLAIMS ALL WARRANTIES, EXPRESS OR IMPLIED, INCLUDING, WITHOUT LIMITATION, ANY IMPLIED WARRANTIES OF MERCHANTABILITY, FITNESS FOR A PARTICULAR PURPOSE, OR NON-INFRINGEMENT OF THIRD PARTY INTELLECTUAL PROPERTY RIGHTS.

These resources are intended for developers skilled in the art designing with Renesas products. You are solely responsible for (1) selecting the appropriate products for your application, (2) designing, validating, and testing your application, and (3) ensuring your application meets applicable standards, and any other safety, security, or other requirements. These resources are subject to change without notice. Renesas grants you permission to use these resources only for development of an application that uses Renesas products. Other reproduction or use of these resources is strictly prohibited. No license is granted to any other Renesas intellectual property or to any third party intellectual property. Renesas disclaims responsibility for, and you will fully indemnify Renesas and its representatives against, any claims, damages, costs, losses, or liabilities arising out of your use of these resources. Renesas' products are provided only subject to Renesas' Terms and Conditions of Sale or other applicable terms agreed to in writing. No use of any Renesas resources expands or otherwise alters any applicable warranties or warranty disclaimers for these products.

(Disclaimer Rev.1.0 Mar 2020)

### Corporate Headquarters

TOYOSU FORESIA, 3-2-24 Toyosu,  
Koto-ku, Tokyo 135-0061, Japan  
[www.renesas.com](http://www.renesas.com)

### Contact Information

For further information on a product, technology, the most up-to-date version of a document, or your nearest sales office, please visit:  
[www.renesas.com/contact/](http://www.renesas.com/contact/)

### Trademarks

Renesas and the Renesas logo are trademarks of Renesas Electronics Corporation. All trademarks and registered trademarks are the property of their respective owners.