



Is Now Part of



ON Semiconductor®

To learn more about ON Semiconductor, please visit our website at
www.onsemi.com

Please note: As part of the Fairchild Semiconductor integration, some of the Fairchild orderable part numbers will need to change in order to meet ON Semiconductor's system requirements. Since the ON Semiconductor product management systems do not have the ability to manage part nomenclature that utilizes an underscore (_), the underscore (_) in the Fairchild part numbers will be changed to a dash (-). This document may contain device numbers with an underscore (_). Please check the ON Semiconductor website to verify the updated device numbers. The most current and up-to-date ordering information can be found at www.onsemi.com. Please email any questions regarding the system integration to Fairchild_questions@onsemi.com.

ON Semiconductor and the ON Semiconductor logo are trademarks of Semiconductor Components Industries, LLC dba ON Semiconductor or its subsidiaries in the United States and/or other countries. ON Semiconductor owns the rights to a number of patents, trademarks, copyrights, trade secrets, and other intellectual property. A listing of ON Semiconductor's product/patent coverage may be accessed at www.onsemi.com/site/pdf/Patent-Marking.pdf. ON Semiconductor reserves the right to make changes without further notice to any products herein. ON Semiconductor makes no warranty, representation or guarantee regarding the suitability of its products for any particular purpose, nor does ON Semiconductor assume any liability arising out of the application or use of any product or circuit, and specifically disclaims any and all liability, including without limitation special, consequential or incidental damages. Buyer is responsible for its products and applications using ON Semiconductor products, including compliance with all laws, regulations and safety requirements or standards, regardless of any support or applications information provided by ON Semiconductor. "Typical" parameters which may be provided in ON Semiconductor data sheets and/or specifications can and do vary in different applications and actual performance may vary over time. All operating parameters, including "Typicals" must be validated for each customer application by customer's technical experts. ON Semiconductor does not convey any license under its patent rights nor the rights of others. ON Semiconductor products are not designed, intended, or authorized for use as a critical component in life support systems or any FDA Class 3 medical devices or medical devices with a same or similar classification in a foreign jurisdiction or any devices intended for implantation in the human body. Should Buyer purchase or use ON Semiconductor products for any such unintended or unauthorized application, Buyer shall indemnify and hold ON Semiconductor and its officers, employees, subsidiaries, affiliates, and distributors harmless against all claims, costs, damages, and expenses, and reasonable attorney fees arising out of, directly or indirectly, any claim of personal injury or death associated with such unintended or unauthorized use, even if such claim alleges that ON Semiconductor was negligent regarding the design or manufacture of the part. ON Semiconductor is an Equal Opportunity/Affirmative Action Employer. This literature is subject to all applicable copyright laws and is not for resale in any manner.



FSA850

Audio 3-Pole / 4-Pole MIC-GND Switch

Features

Switch Type	3-Pole/4-Pole MIC - GND
V _{CC}	2.3 to 4.5 V
THD (MIC)	0.001% Typical
ESD	
IEC 61000-4-2 (Air Gap)	15 kV
IEC 61000-4-2 (Contact)	8 kV
HBM (All Pins)	3 kV
GNDnA/GNDnB to GND	8 kV
Power to GND	10 kV
CDM	2 kV
Operating Temperature	-40°C to 85°C
R _{ON} Maximum (GND1n)	0.08 Ω
R _{ON} Maximum (SENSE)	1 Ω

Description

The FSA850 is a 3-pole or 4-pole audio jack microphone GND switch for accessories with General-Purpose Input / Output (GPIO) control signals. The FSA850 also has the ability to perform 4-pole cross-point switching to support Open Mobile Terminal Platform (OMTP) 4-pole headset plugs. The architecture is designed to replace discrete MOSFET solutions and allow common third-party headphones to be used for listening to music or playing video from mobile handsets, personal media players, and portable peripheral devices.

- Supports 4-Pole OMTP Cross Point Switching for GND Connection
- Integrates a MIC switch for 3- or 4-Pole Configuration Headset Plugs
- Reduces “Pop and Click” Caused by Microphone Bias

Applications

- 3.5 mm and 2.5 mm Audio Jacks
- Cellular Phones, Smart Phones
- MP3 and PMP (Portable Media Player)

Ordering Information

Part Number	Operating Temperature Range	Top Mark	Package	Packing Method
FSA850UCX	-40 to +85°C	M5	12-Ball, Wafer-Level Chip-Scale Package (WLCSP), 3x4 Array, 0.4mm Pitch, 250 μm Ball	3000 units on Tape & Reel

Typical Application

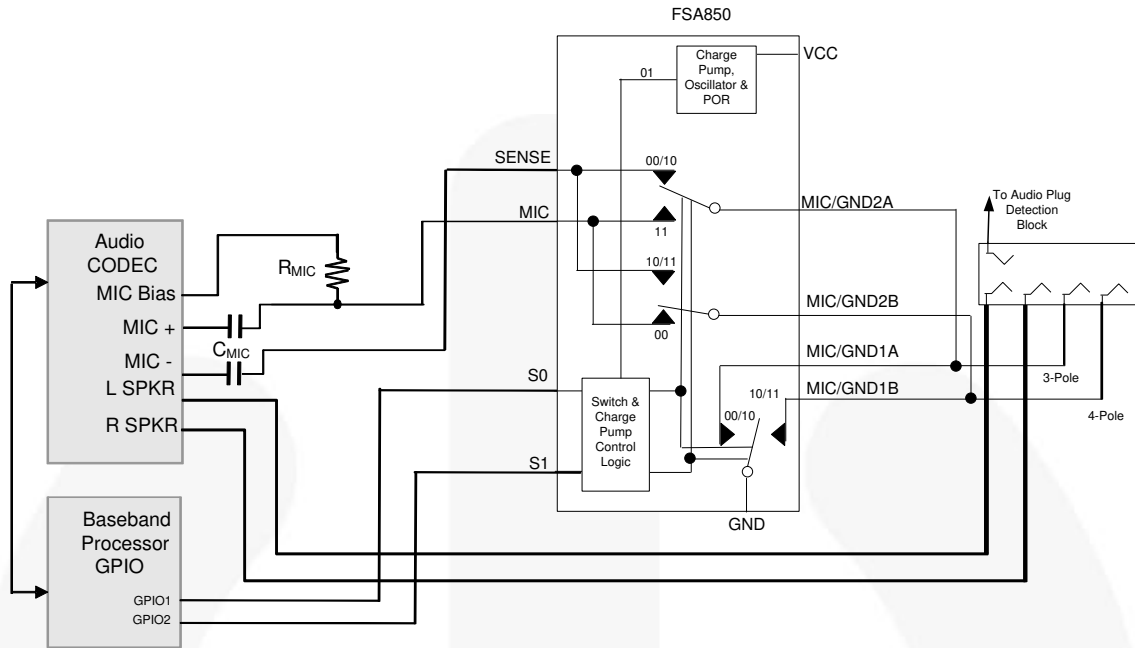

Figure 1. Typical Mobile Application

Analog Symbol

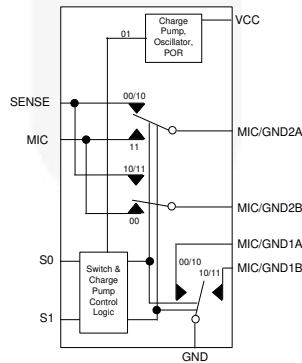

Figure 2. Analog Symbol

Table 1. Functional Truth Table

S0	S1	GND	SENSE	MIC
0	0	MIC/GND1A	MIC/GND2A	MIC/GND2B
0	1	HIGH-Z	HIGH-Z	HIGH-Z
1	0	MIC/GND1A & MIC/GND1B	MIC/GND2A & MIC/GND2B	HIGH-Z
1	1	MIC/GND1B	MIC/GND2B	MIC/GND2A

Pin Assignments

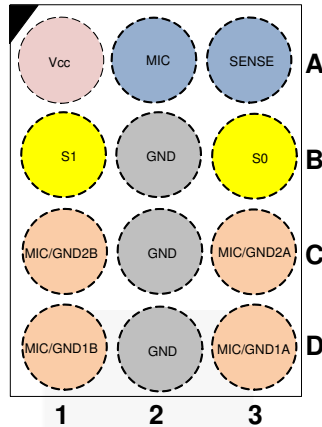

Figure 3. Pin Assignments (Top Through View, Top Mark Side)

Pin Descriptions

Name	Ball #	Type	Description
MIC	A2	Switch	Microphone, connects to microphone pre-amplifier
SENSE	A3	Switch	Sense pin to detect GND offset
S0, S1	B3, B1	Input	MIC, SENSE, and MIC/GNDn switch-select pin
MIC/GND1A	D3	Switch	GND switch, connects to pole 3 of audio jack
MIC/GND2A	C3	Switch	GND switch, connects to pole 3 of audio jack
MIC/GND1B	D1	Switch	GND switch, connects to pole 4 of audio jack
MIC/GND2B	C1	Switch	GND switch, connects to pole 4 of audio jack
V _{CC}	A1	Power	Supply voltage
GND	B2,C2,D2	Ground	Ground for both the audio jack and PCB

Absolute Maximum Ratings

Stresses exceeding the Absolute Maximum Ratings may damage the device. The device may not function or be operable above the recommended operating conditions and stressing the parts to these levels is not recommended. In addition, extended exposure to stresses above the recommended operating conditions may affect device reliability. The absolute maximum ratings are stress ratings only.

Symbol	Parameter		Min.	Max.	Unit
V_{CC}	Supply Voltage from Battery		-0.5	+5.5	V
V_{CTRL}	Control Input Voltage (S0, S1)		-0.5	V_{CC}	V
V_{SWM}, V_{SWG}	Switch I/O Voltage (SENSE, MIC, MIC/GND1A, MIC/GND2A, MIC/GND1B, MIC/GND2B)		-0.5	$V_{CC}+0.5$	V
I_{IK}	Input Clamp Diode Current ⁽¹⁾		-50		mA
I_{SW}	Switch I/O Current (Continuous) ⁽¹⁾ (SENSE, MIC, MIC/GND2A, MIC/GND2B)			50	mA
I_D	GND Switch I/O Current (Continuous) ⁽¹⁾ (MIC/GND1A, MIC/GND1B)			300	mA
T_{STG}	Storage Temperature Range		-65	+150	°C
T_J	Maximum Junction Temperature			+150	°C
T_L	Lead Temperature (Soldering, 10 Seconds)			+260	°C
ESD	IEC 61000-4-2 System ESD	Air Gap		15	kV
		Contact		8	
	Human Body Model, JEDEC JESD22-A114	All Other Pins (S0,S1, SENSE, MIC)		3	
		I/O to GND (MIC/GND1A, MIC/GND2A, MIC/GND1B, MIC/GND2B)		8	
		Power to GND		10	
		Charged Device Model, JEDEC JESD22-C101	All Pins		

Note:

- The input and output negative ratings may be exceeded if the input and output diode current ratings are observed.

Recommended Operating Conditions

The Recommended Operating Conditions table defines the conditions for actual device operation. Recommended operating conditions are specified to ensure optimal performance to the datasheet specifications. Fairchild does not recommend exceeding them or designing to Absolute Maximum Ratings.

Symbol	Parameter		Min.	Max.	Unit
V_{CC}	Battery Supply Voltage		2.3	4.5	V
V_{CTRL}	Control Input Voltage (S0, S1)		0	V_{CC}	V
V_{SWM}	Switch I/O Voltage (MIC)		0	V_{CC}	V
V_{SWG}	Switch I/O Voltage (SENSE, MIC/GND1A, MIC/GND2A, MIC/GND1B, MIC/GND2B)		0	1.0	V
T_A	Operating Temperature		-40	+85	°C

DC Electrical Characteristics

All typical values are at $T_A = 25^\circ\text{C}$ and $V_{CC} = 3.3\text{V}$ unless otherwise specified.

Symbol	Parameter	Condition	V_{CC} (V)	$T_A = -40^\circ\text{C}$ to $+85^\circ\text{C}$			Unit
				Min.	Typ.	Max.	
V_{IK}	Clamp Diode Voltage	$I_{IN} = -18\text{ mA}$	2.8			-1.2	V
V_{IH}	Input Voltage High	$V_{CNTRL} = 0$ to V_{CC}	2.3 to 4.5	1.0			V
V_{IL}	Input Voltage Low	$V_{CNTRL} = 0$ to V_{CC}	2.3 to 4.5			0.5	V
I_{IN}	Control Input Leakage (S0,S1)	$V_{CNTRL} = 0$ to V_{CC}	4.5	-1		1	μA
I_{OZ}	Off Leakage Current of Ports – Sense, MIC, MIC/GNDnA, and MIC/GNDnB	S[0:1]=01; SENSE=MIC=0.3 V; $V_{CC}=0.3\text{ V}$; MIC/GNDnA or MIC/GNDnB=1V0.3V or Floating	2.3 to 4.5	-1.00	0.05	1.00	μA
I_{AON}	On Leakage Current of Ports – Sense, MIC, MIC/GNDnA, and MIC/GNDnB	S[0:1]=00, 10, 11; SENSE=MIC=0.3V; $V_{CC}=0.3\text{V}$; MIC/GNDnA or MIC/GNDnB=1V0.3V or Floating	2.3 to 4.5	-1.00	0.05	1.00	μA
I_{CC}	Quiescent Supply Current	$V_{SWG}=0$ or 1 V ; $V_{SWM}=0$ or V_{CC} ; $I_{OUT}=0$	4.5		15	20	μA
I_{CCZ}	Quiescent Supply Current – Hi-Z	S[0:1]=01; $V_{SWG}=0$ or 1 V ; $V_{SWM}=0$ or V_{CC} , $I_{OUT}=0$	4.5		0.2	1.0	μA
I_{CCT}	Increase in I_{CC} Current Per Control Voltage and V_{CC}	S0, S1=1.65 V	4.5			3	μA
R_{ON_SEN}	Switch On Resistance for SENSE Switch Paths	$I_{ON} = -24\text{ mA}$, S[0:1]=00 or 11 MIC/GND2A or MIC/GND2B=1.0 V	2.3		0.6	1.0	Ω
R_{ONFLAT_SEN}	On Resistance Flatness for SENSE Switch Paths	$I_{ON} = -24\text{ mA}$, S[0:1]=00 or 11 MIC/GND2A or MIC/GND2B=0 to 1.0 V	2.3		0.05	0.20	Ω
R_{ON_MIC}	Switch On Resistance for MIC Switch Paths	$I_{ON} = -24\text{ mA}$, S[0:1]=00 or 11 MIC/GND2A or MIC/GND2B=1.0V	2.3		0.6	1.0	Ω
R_{ONFLAT_MIC}	On Resistance Flatness for MIC Switch Path	$I_{ON} = -24\text{ mA}$, S[0:1]=00 or 11 MIC/GND2A or MIC/GND2B=0.5 to V_{CC}	2.3		.08	0.5	Ω
V_{MIC}	MIC Input Signal Range		2.3 to 4.5	0		V_{CC}	V
$R_{DSON(GND)}$	GND Switch On Resistance	$I_{ON} = -200\text{ mA}$, S[0:1]=00 or 11 MIC/GND1A or MIC/GND1B	2.3		40	80	m Ω
V_{SENSE}	SENSE Input Signal Range		2.3 to 4.5	0		1	V

AC Electrical Characteristics

All typical values are at $T_A = 25^\circ\text{C}$ and $V_{CC} = 3.3\text{V}$ unless otherwise specified.

Symbol	Parameter	Condition	V_{CC} (V)	$T_A = -40^\circ\text{C to } +85^\circ\text{C}$			Unit
				Min.	Typ.	Max.	
t_{ON_MIC}	Turn-On Time (MIC, SENSE) S0, S1 to Output	$R_L=10\text{ k}\Omega$, $C_L=10\text{ pF}$	2.3 to 4.5			1	μs
t_{OFF_MIC}	Turn-Off Time (MIC, SENSE) S0,S1 to Output	$R_L=10\text{ k}\Omega$, $C_L=10\text{ pF}$	2.3 to 4.5			1	μs
t_{ENABLE}	Enable Time (MIC, SENSE) S0,S1 to Output	$S[0:1]=01\text{ to }00,10,11$, $R_L=10\text{ k}\Omega$, $C_L=10\text{ pF}$	2.3 to 4.5		1		μs
$t_{DISABLE}$	Turn-Off Time (MIC, SENSE) S0,S1 to Output	$S[0:1]=00,10,11\text{ to }01$, $R_L=10\text{ k}\Omega$, $C_L=10\text{ pF}$	2.3 to 4.5		1		μs

MIC and SENSE Switch

Symbol	Parameter	Condition	V_{CC} (V)	$T_A = -40\text{ to } +85^\circ\text{C}$			Unit
				Min.	Typ.	Max.	
THD	Total Harmonic Distortion - MIC	$R_T=600\ \Omega$, $V_{SW}=0.5\ V_{PP}$, $f=20\text{ Hz to }20\text{ kHz}$, $V_{IN}=1.8\text{ V}$	2.8		0.001		%
O_{IRRM}	Off Isolation – MIC/SENSE	$f=20\text{ kHz}$, $R_S=600\ \Omega$, $C_L=0\text{ pF}$, $R_T=600\ \Omega$, $V_{SW}=0.2\ V_{PP}$	2.8		-88		dB
X_{TALKM}	Crosstalk from MIC to SENSE	$f=1\text{ MHz}$, $R_L=100\ \Omega$	2.8		-80		dB
$X\text{-Talk}_{System}$	X-Talk Between Left and Right Speakers	$f=2\text{ kHz}$, $R_L=32\ \Omega$, $C_L=0\text{ pF}$, $V_{IN}=100\text{ mV}_{RMS}$	2.8		-54		dB

Capacitance

Symbol	Parameter	Condition	$T_A = -40^\circ\text{C to } +85^\circ\text{C}$			Unit
			Min.	Typ.	Max.	
C_{IN}	Control Pin Input Capacitance (S0, S1)	$V_{CC}=0\text{ V}$, $f=1\text{ MHz}$		1.7		pF
C_{ONM}	On Capacitance	$V_{CC}=2.8\text{ V}$, $EN=V_{CC}$, $f=1\text{ MHz}$,		65		
				75		
C_{OFFM}	Off Capacitance	$V_{CC}=2.8\text{ V}$, $EN=0\text{ V}$, $f=1\text{ MHz}$,		25		
				30		

Power

Symbol	Parameter	Conditions	V_{CC} (V)	$T_A = -40\text{ to } +85^\circ\text{C}$			Unit
				Min.	Typ.	Max.	
PSRR	Power Supply Rejection Ratio	Power Supply Noise at 300 mV_{PP} , Measured 10/90%, $f=217\text{ Hz}$	2.8	-80			dB
IL	Insertion Loss through Switch (V_{OUT}/V_{IN})	SENSE/MIC: $V_{IN}=400\text{ mV}_{pk-pk}$, $f=20\text{ kHz}$, DC Bias= 0.3 V , $R_L=600\ \Omega$	2.8		-0.4		dB
		SENSE/MIC: $V_{IN}=400\text{ mV}_{pk-pk}$, $f=20\text{ kHz}$, DC Bias= 2.5 V , $R_L=600\ \Omega$	2.8		-0.4		

The following information applies to the WL-CSP package dimensions on the next page:

Product Specific Dimensions

D	E	X	Y
1.56 mm	1.16 mm	0.18 mm	0.18 mm

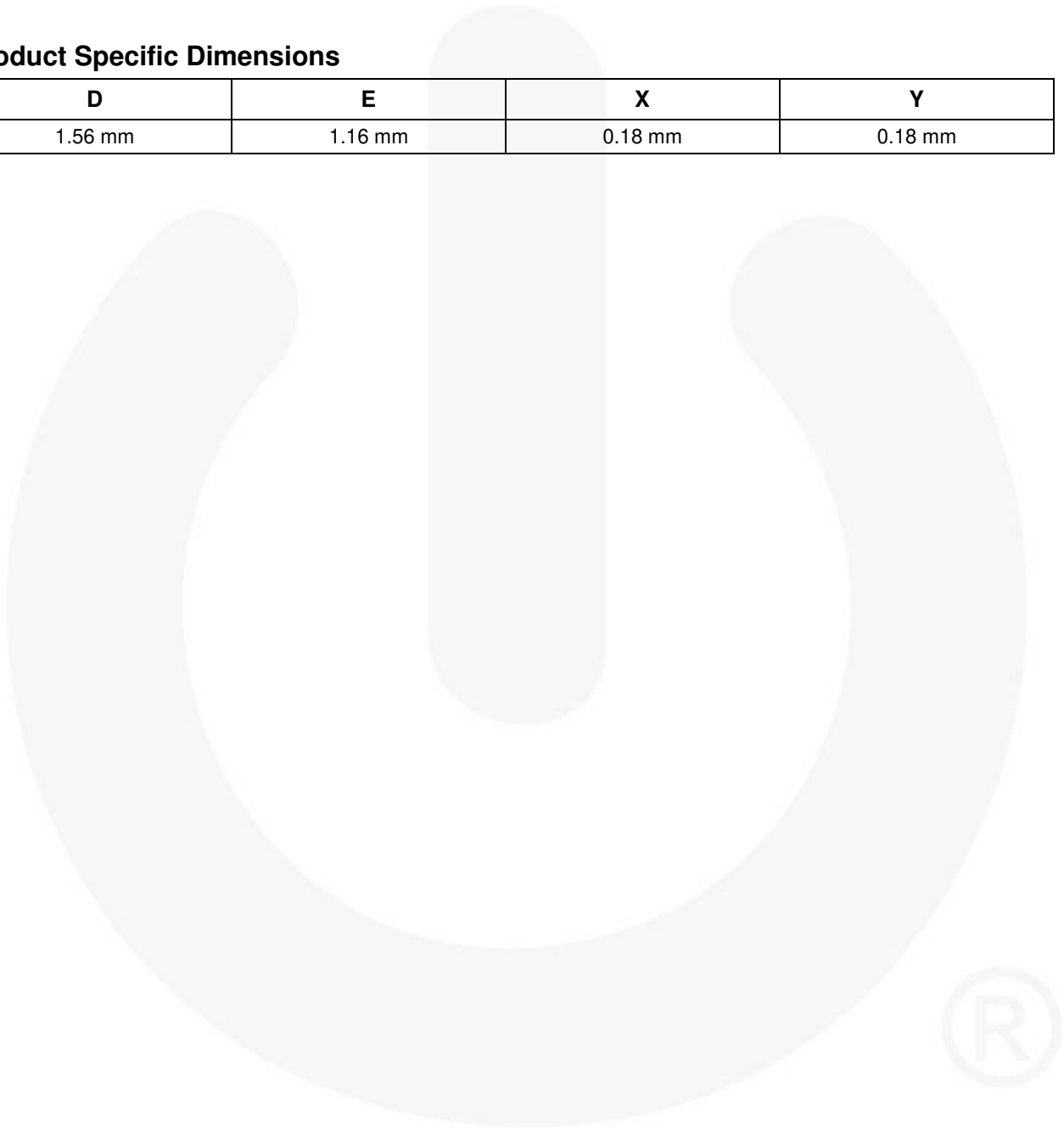

REVISIONS			
REV	DESCRIPTION	DATE	APP'D / SITE
1	Initial drawing release.	8-19-09	L. England / FSME

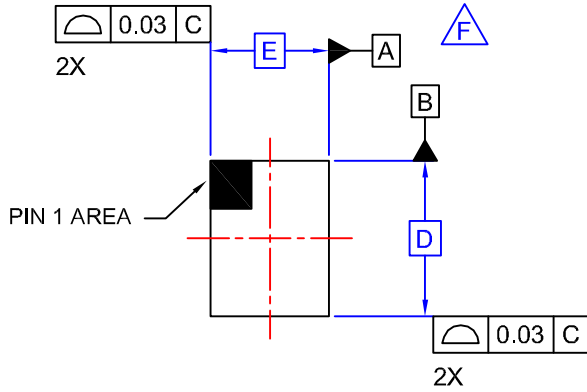

TOP VIEW

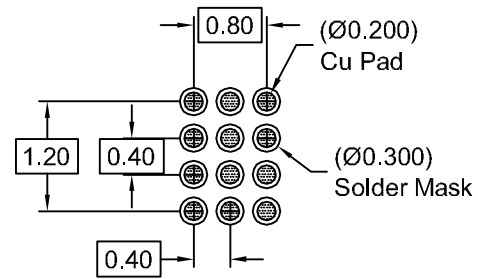

RECOMMENDED LAND PATTERN
(NSMD PAD TYPE)

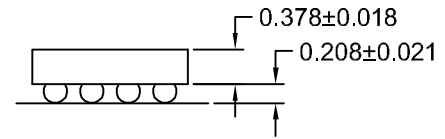
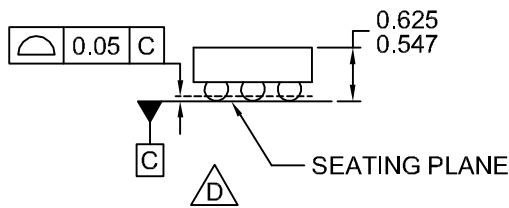

SIDE VIEWS

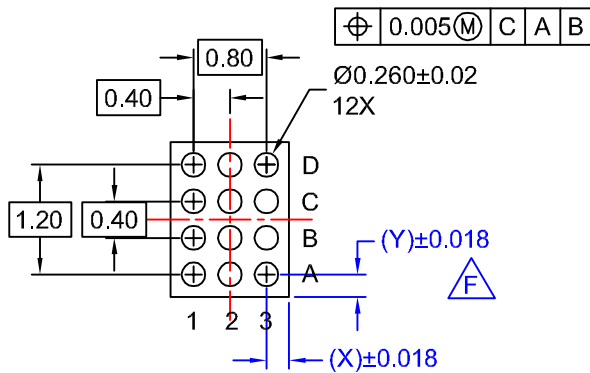

BOTTOM VIEW

NOTES:

- A. NO JEDEC REGISTRATION APPLIES.
- B. DIMENSIONS ARE IN MILLIMETERS.
- C. DIMENSIONS AND TOLERANCES PER ASME Y14.5M, 1994.
- D. DATUM C IS DEFINED BY THE SPHERICAL CROWNS OF THE BALLS.
- E. PACKAGE NOMINAL HEIGHT IS 586 MICRONS ±39 MICRONS (547-625 MICRONS).
- F. FOR DIMENSIONS D, E, X, AND Y SEE PRODUCT DATASHEET.
- G. DRAWING FILENAME: MKT-UC012ACrev1.

APPROVALS		DATE	FAIRCHILD SEMICONDUCTOR™			
DRAWN	L. England	8-19-09	12BALL WLCSP, 3X4 ARRAY 0.4MM PITCH, 250UM BALL			
DFTG. CHK.	S. Martin	8-19-09				
ENGR. CHK.						
			SCALE	SIZE	DRAWING NUMBER	REV
			N/A	N/A	MKT-UC012AC	1
			DO NOT SCALE DRAWING		SHEET 1 of 1	

ON Semiconductor and  are trademarks of Semiconductor Components Industries, LLC dba ON Semiconductor or its subsidiaries in the United States and/or other countries. ON Semiconductor owns the rights to a number of patents, trademarks, copyrights, trade secrets, and other intellectual property. A listing of ON Semiconductor's product/patent coverage may be accessed at www.onsemi.com/site/pdf/Patent-Marking.pdf. ON Semiconductor reserves the right to make changes without further notice to any products herein. ON Semiconductor makes no warranty, representation or guarantee regarding the suitability of its products for any particular purpose, nor does ON Semiconductor assume any liability arising out of the application or use of any product or circuit, and specifically disclaims any and all liability, including without limitation special, consequential or incidental damages. Buyer is responsible for its products and applications using ON Semiconductor products, including compliance with all laws, regulations and safety requirements or standards, regardless of any support or applications information provided by ON Semiconductor. "Typical" parameters which may be provided in ON Semiconductor data sheets and/or specifications can and do vary in different applications and actual performance may vary over time. All operating parameters, including "Typicals" must be validated for each customer application by customer's technical experts. ON Semiconductor does not convey any license under its patent rights nor the rights of others. ON Semiconductor products are not designed, intended, or authorized for use as a critical component in life support systems or any FDA Class 3 medical devices or medical devices with a same or similar classification in a foreign jurisdiction or any devices intended for implantation in the human body. Should Buyer purchase or use ON Semiconductor products for any such unintended or unauthorized application, Buyer shall indemnify and hold ON Semiconductor and its officers, employees, subsidiaries, affiliates, and distributors harmless against all claims, costs, damages, and expenses, and reasonable attorney fees arising out of, directly or indirectly, any claim of personal injury or death associated with such unintended or unauthorized use, even if such claim alleges that ON Semiconductor was negligent regarding the design or manufacture of the part. ON Semiconductor is an Equal Opportunity/Affirmative Action Employer. This literature is subject to all applicable copyright laws and is not for resale in any manner.

PUBLICATION ORDERING INFORMATION

LITERATURE FULFILLMENT:

Literature Distribution Center for ON Semiconductor
19521 E. 32nd Pkwy, Aurora, Colorado 80011 USA
Phone: 303-675-2175 or 800-344-3860 Toll Free USA/Canada
Fax: 303-675-2176 or 800-344-3867 Toll Free USA/Canada
Email: orderlit@onsemi.com

N. American Technical Support: 800-282-9855 Toll Free
USA/Canada
Europe, Middle East and Africa Technical Support:
Phone: 421 33 790 2910
Japan Customer Focus Center
Phone: 81-3-5817-1050

ON Semiconductor Website: www.onsemi.com
Order Literature: <http://www.onsemi.com/orderlit>
For additional information, please contact your local
Sales Representative