

1 FRDMGD31RPEVM

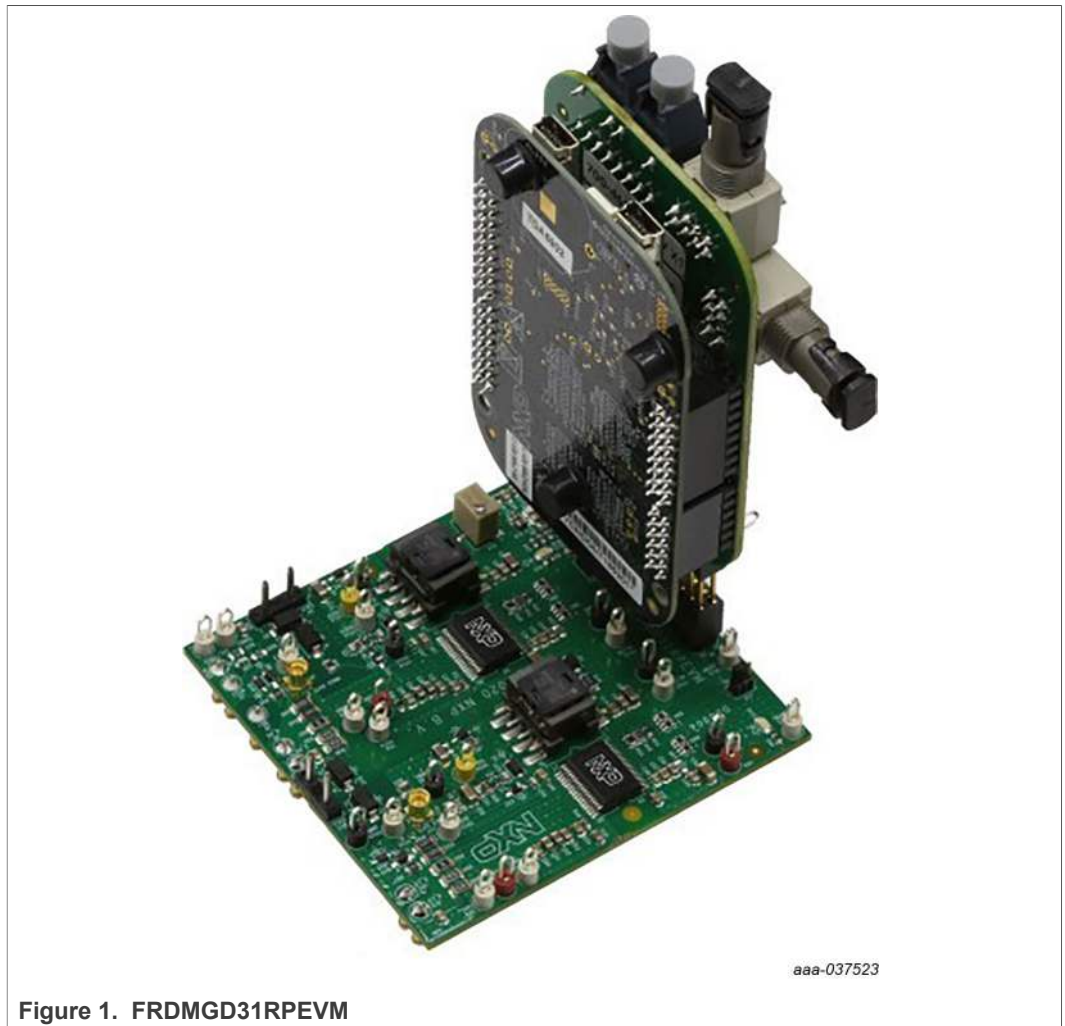

Figure 1. FRDMGD31RPEVM

2 Important notice

NXP provides the enclosed product(s) under the following conditions:

This evaluation kit is intended for use of ENGINEERING DEVELOPMENT OR EVALUATION PURPOSES ONLY. It is provided as a sample IC pre-soldered to a printed circuit board to make it easier to access inputs, outputs, and supply terminals. This evaluation board may be used with any development system or other source of I/O signals by simply connecting it to the host MCU or computer board via off-the-shelf cables. This evaluation board is not a Reference Design and is not intended to represent a final design recommendation for any particular application. Final device in an application will be heavily dependent on proper printed circuit board layout and heat sinking design as well as attention to supply filtering, transient suppression, and I/O signal quality.

The goods provided may not be complete in terms of required design, marketing, and or manufacturing related protective considerations, including product safety measures typically found in the end product incorporating the goods. Due to the open construction of the product, it is the user's responsibility to take any and all appropriate precautions with regard to electrostatic discharge. In order to minimize risks associated with the customers applications, adequate design and operating safeguards must be provided by the customer to minimize inherent or procedural hazards. For any safety concerns, contact NXP sales and technical support services.

Should this evaluation kit not meet the specifications indicated in the kit, it may be returned within 30 days from the date of delivery and will be replaced by a new kit.

NXP reserves the right to make changes without further notice to any products herein. NXP makes no warranty, representation or guarantee regarding the suitability of its products for any particular purpose, nor does NXP assume any liability arising out of the application or use of any product or circuit, and specifically disclaims any and all liability, including without limitation consequential or incidental damages. Typical parameters can and do vary in different applications and actual performance may vary over time. All operating parameters, including Typical, must be validated for each customer application by customer's technical experts.

NXP does not convey any license under its patent rights nor the rights of others. NXP products are not designed, intended, or authorized for use as components in systems intended for surgical implant into the body, or other applications intended to support or sustain life, or for any other application in which the failure of the NXP product could create a situation where personal injury or death may occur.

Should the Buyer purchase or use NXP products for any such unintended or unauthorized application, the Buyer shall indemnify and hold NXP and its officers, employees, subsidiaries, affiliates, and distributors harmless against all claims, costs, damages, and expenses, and reasonable attorney fees arising out of, directly or indirectly, any claim of personal injury or death associated with such unintended or unauthorized use, even if such claim alleges NXP was negligent regarding the design or manufacture of the part.

3 Getting started

The NXP analog product development boards provide an easy-to-use platform for evaluating NXP products. The boards support a range of analog, mixed-signal, and power solutions. They incorporate monolithic integrated circuits and system-in-package devices that use proven high-volume technology. NXP products offer longer battery life, a smaller form factor, reduced component counts, lower cost, and improved performance in powering state-of-the-art systems.

The tool summary page for FRDMGD31RPEVM is at <http://www.nxp.com/FRDMGD31RPEVM>. The overview tab provides an overview of the device, product features, a description of the kit contents, a list of (and links to) supported devices, a list of (and links to) any related products, and a **Get Started** section.

The **Get Started** section provides links to everything needed to start using the device and contains the most relevant, current information applicable to the FRDMGD31RPEVM.

1. Go to <http://www.nxp.com/FRDMGD31RPEVM>.
2. On the **Overview** tab, locate the **Jump To** navigation feature on the left side of the window.
3. Select the **Get Started** link, review each entry, and download an entry by clicking the title.
4. After reviewing the **Overview** tab, visit the other product-related tabs for additional information:
 - **Documentation**: download current documentation
 - **Software & Tools**: download current hardware and software tools
 - **Buy/Parametrics**: purchase the product and view the product parametrics

After downloading files, review each file, including the user guide, which includes setup instructions. If applicable, the bill of materials (BOM) and supporting schematics are also available for download in the **Get Started** section of the **Overview** tab.

3.1 Kit contents/packing list

The FRDMGD31RPEVM kit contents include:

- Assembled and tested FRDMGD31RPEVM board in an anti-static bag
- 3.3 V to 5.0 V translator board (KITGD3160TREVb) connected to FRDM-KL25Z
- USB cable, type A male/type mini B male, 3 ft
- Quick start guide

3.2 Required equipment

To use this kit, you need:

- Compatible SiC RoadPak module
- DC link capacitor compatible with the SiC RoadPak module
- 1.27 mm jumpers for configuration (included with kit)
- 30 μ H to 50 μ H, high current air core inductor for double pulse testing
- HV power supply with protection shield and hearing protection
- 25 V, 1.0 A DC power supply
- 500 MHz 2.5 GS/s 4-channel oscilloscope
- Rogowski coil, PEM Model CWT Mini HF60R, or CTW MiniHF30 (smaller diameter)
- Isolated high-voltage probe (CAL Test Electric CT2593-1, LeCroy AP030)
- Digital voltmeter

3.3 System requirements

The kit requires the following to function properly with the software:

- Windows 7 or higher operating system

4 Getting to know the hardware

4.1 Overview

The FRDMGD31RPEVM is a half-bridge evaluation kit populated with two GD3100 single channel gate drive devices. The kit includes the Freedom KL25Z microcontroller hardware for interfacing a PC installed with FlexGUI software for communication to the serial peripheral interface (SPI) registers on the GD3100 gate drive devices in either daisy chain or standalone configuration.

The KITGD3160TREV translator board is used to translate 3.3 V signals to 5.0 V signals between the MCU and GD3100 gate drivers. The evaluation kit can be connected to a compatible insulated gate bipolar transistor (IGBT) or SiC module for half-bridge evaluations and applications development.

4.2 Board features

- Capability to connect to RoadPak SiC module for half-bridge evaluations
- Negative VEE gate low drive level (-3.9 V DC)
- VCCREG regulated high gate drive level (+15 V DC)
- Jumper configurable for disabling dead time fault protection when short-circuit testing
- Easy access power, ground, and signal test points
- Easy to install and use FlexGUI for interfacing via SPI through PC; software includes double pulse and short-circuit testing capability
- DC link bus voltage monitor on low-side driver via AMUXIN and AOUT
- Negative temperature coefficient (NTC) connection and configurable for monitoring module temperature

4.3 Device features

Table 1. Device features

Device	Description	Features
GD3100	The GD3100 is an advanced single channel gate driver for IGBTs.	<ul style="list-style-type: none"> • Compatible with current sense and temp sense IGBTs • DESAT detection capability for detecting V_{CE} desaturation condition • Fast short-circuit protection for IGBTs with current sense feedback • Compliant with automotive safety integrity level (ASIL) C/D ISO 26262 functional safety requirements • SPI interface for safety monitoring, programmability, and flexibility • Integrated galvanic signal isolation • Integrated gate drive power stage capable of 10 A peak source and sink • Interrupt pin for fast response to faults • Compatible with negative gate supply • Compatible with 200 V to 1700 V IGBTs, power range > 125 kW

4.4 Board description

The FRDMGD31RPEVM is a half-bridge evaluation board populated with two GD3100 single channel IGBT or SiC gate drive devices. The board supports connection to an FRDM-KL25Z microcontroller for SPI communication configuration programming and monitoring. The board includes DESAT circuitry for short-circuit detection and implementation of GD3100 shutdown protection capabilities.

The evaluation board is designed to connect to a RoadPak SiC metal-oxide-semiconductor field-effect transistor (MOSFET) for evaluation of the GD3100 performance and capabilities.

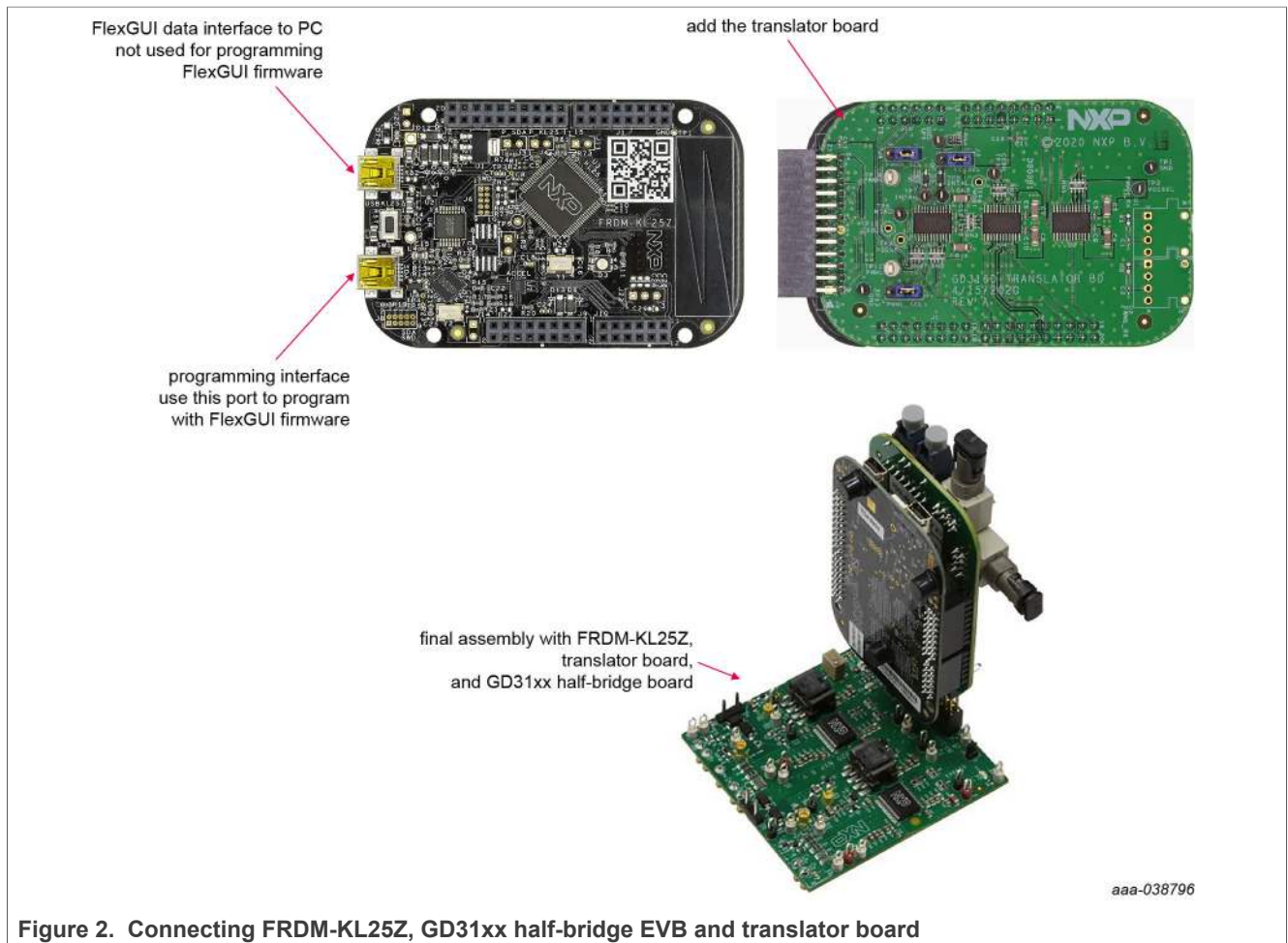

Figure 2. Connecting FRDM-KL25Z, GD31xx half-bridge EVB and translator board

4.4.1 Low-voltage logic and control connector

Low-voltage domain is 12 V VSUP domain that interfaces with the MCU and GD3100 control registers through the 24-pin connector interface.

Low-side driver and high-side driver domains are driver control interfaces to RoadPak module single phase connections and test points.

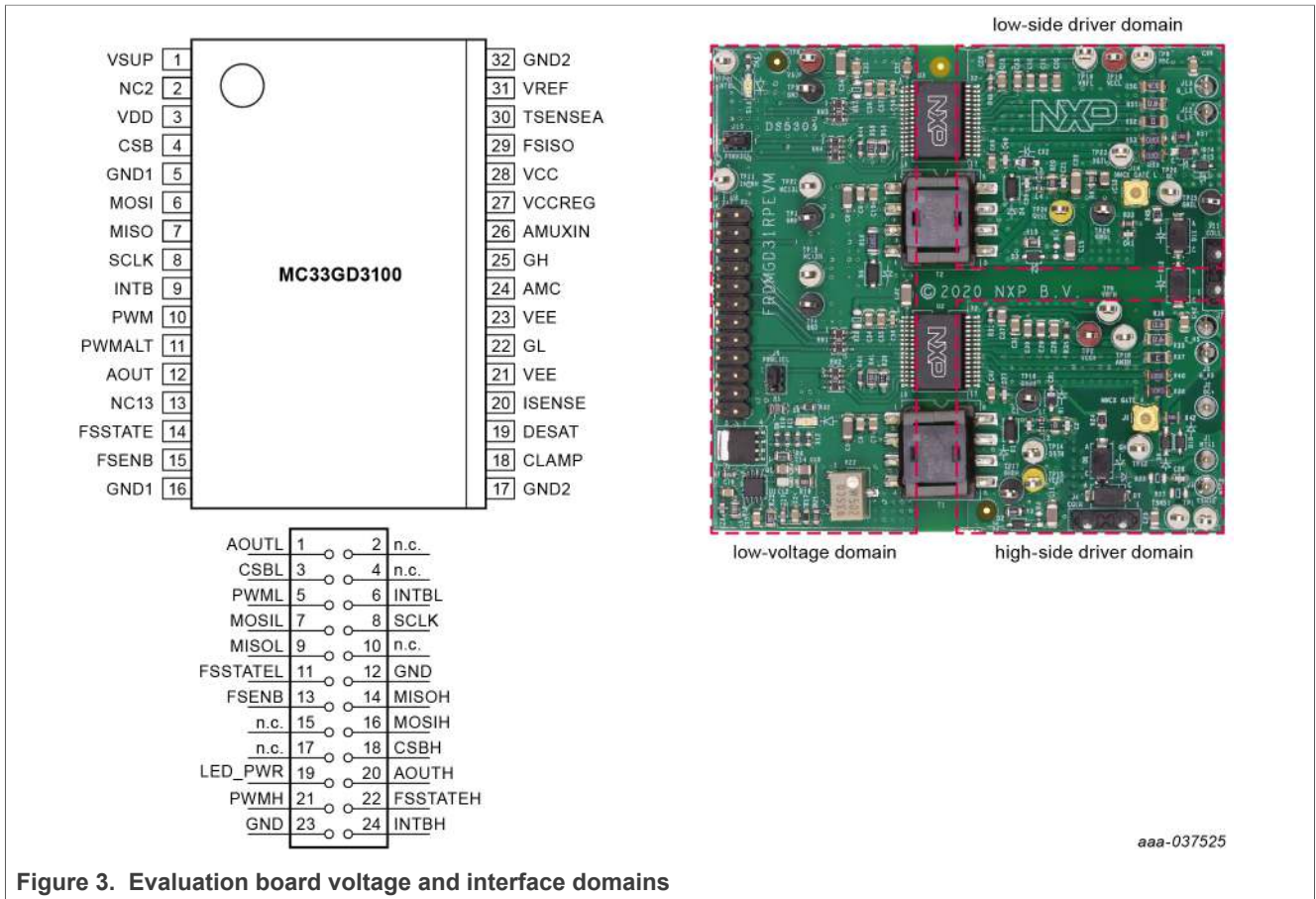

Figure 3. Evaluation board voltage and interface domains

Table 2. Low-voltage domain 24-pin connector definitions

Pin	Name	Function
1	AOUTL	analog output duty cycle encoded signal (low side) for reading temperature via TSENSEA or voltage via AMUXIN
2	n.c.	not connected
3	CSBL	chip select bar (low side)
4	n.c.	not connected
5	PWML	pulse width modulation (PWM) input (low side)
6	INTBL	interrupt bar (low side)
7	MOSIL	master out slave in (low side)
8	SCLK	serial clock input
9	MISOL	master in slave out (low side)
10	n.c.	not connected
11	FSSTATEL	fail-safe state (low side)
12	GND	ground
13	FSENB	fail-safe enable (high side and low side)
14	MISOH	master in slave out (high side)

Table 2. Low-voltage domain 24-pin connector definitions...continued

Pin	Name	Function
15	n.c.	not connected
16	MOSIH	master out slave in (high side)
17	n.c.	not connected
18	CSBH	chip select bar (high side)
19	LED_PWR	USB 3.3 V power for INTB LEDs (high side and low side)
20	AOUTH	duty cycle encoded signal (high side)
21	PWMH	PWM input (high side)
22	FSSTATEH	fail-safe state (high side)
23	GND	ground
24	INTBH	interrupt bar (high side)

4.4.2 Test point definitions

All test points are clearly marked on the evaluation board. Figure 4 shows the location of various test points.

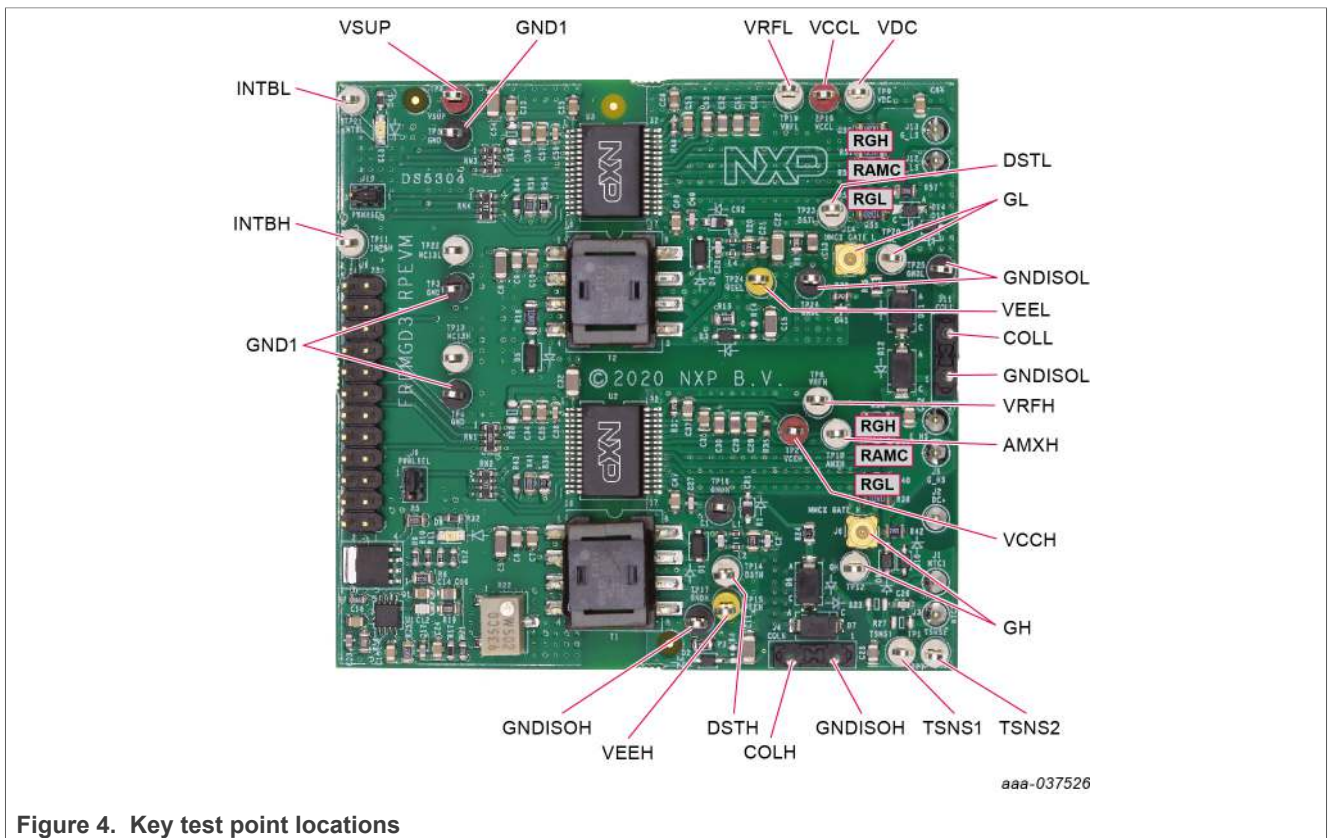

Figure 4. Key test point locations

Table 3. Test point definitions

Test point	Definition
Low-voltage domain	
VSUP	DC voltage source connection point for VSUP power input of GD3100 devices. Typically supplied by vehicle battery +12 V DC.
GND1	grounding points for low-voltage domain
INTBL	interrupt bar low-side test point
INTBH	interrupt bar high-side test point
Low-side driver domain	
VCCL	positive voltage supply test point for isolated circuitry and low-side driver domain
DSTL	V_{CE} desaturation test point connected to low-side driver DESAT pin and circuitry
VEEL	negative voltage supply test point for low-side driver gate of IGBT or SiC module
VDC	DC link voltage test point at voltage divider
VRFL	5.0 V reference test point for isolated analog circuitry on low-side driver
GNDISOL	low-side driver grounding points
GL	module gate test point on low-side driver domain which is the charging pin of gate; including MMCX probe connection
COLL	collector test point/connection terminal on low side
High-side driver domain	
VCCH	positive voltage supply test point for isolated circuitry and high-side driver domain
DSTH	V_{CE} desaturation test point connected to high-side driver DESAT pin and circuitry
VEEH	negative voltage supply test point for high-side driver gate of IGBT or SiC module
AMXH	analog MUX input test point for high-side driver
VRFH	5.0 V reference test point for isolated analog circuitry on high-side driver
TSNS1	NTC1 test point at module and TSENSEH high-side
TSNS2	NTC2 test point at module and GNDISOH
GNDISOH	high-side driver grounding points
GH	module gate test point on high-side driver domain which is the charging pin of gate; including MMCX probe connection
COLH	collector test point/connection high side

4.4.3 Power supply and jumper configuration

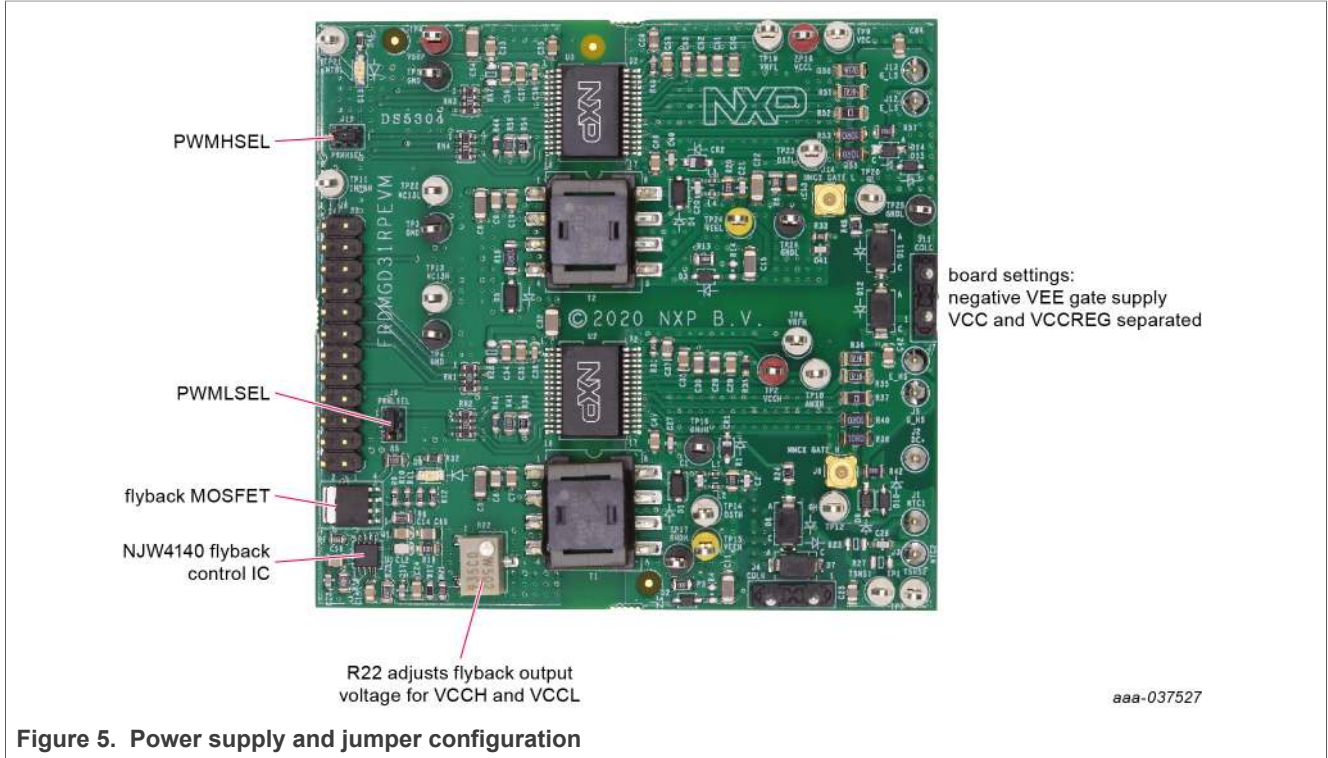

Figure 5. Power supply and jumper configuration

Table 4. Jumper definitions

Jumper	Position	Function
PWMHSEL (J10)	1-2	dead time fault protection enabled (high side)
	2-3	dead time fault protection disabled (use for short-circuit testing)
PWMLSEL (J9)	1-2	dead time fault protection enabled (low side)
	2-3	dead time fault protection disabled (use for short-circuit testing)

4.4.4 Bottom view

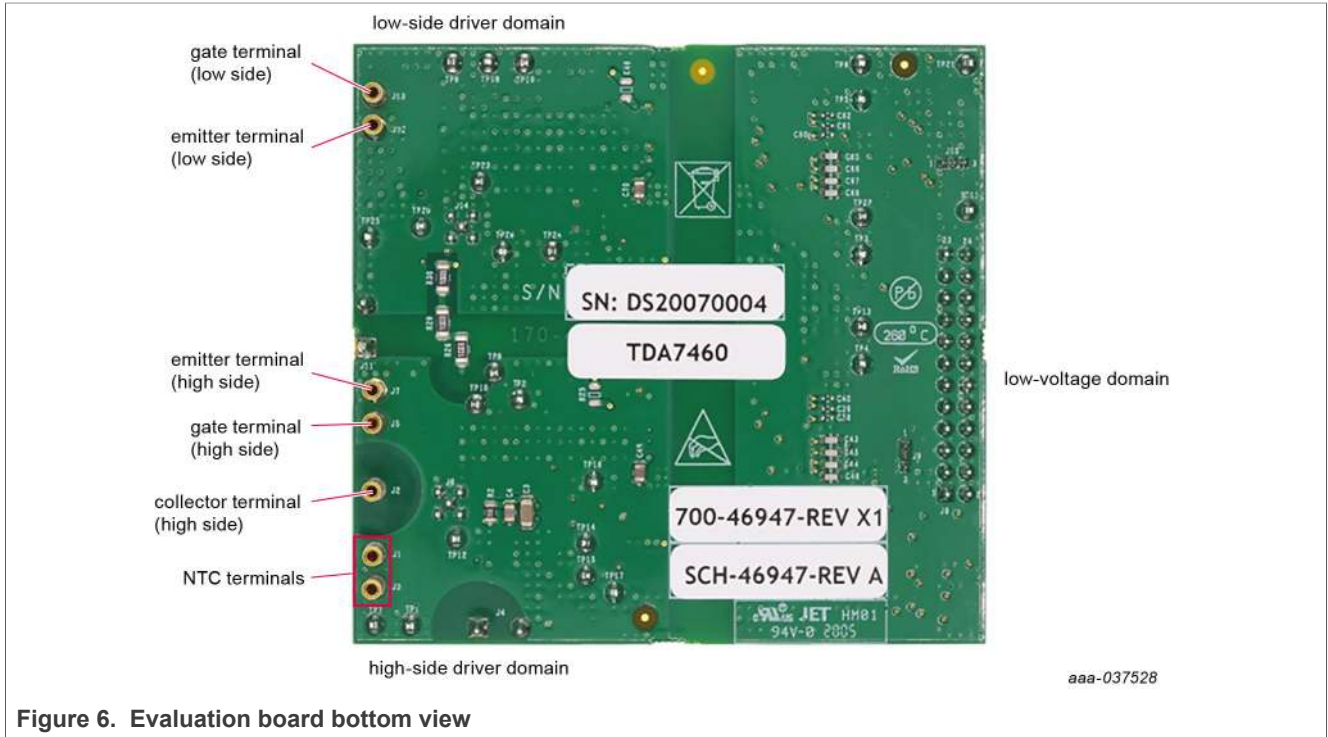

Figure 6. Evaluation board bottom view

4.4.5 Gate drive resistors

- RGH - gate high resistor in series with the GH pin at the output of the GD3100 gate high driver and RoadPak module gate that controls the turn-on current for SiC MOSFET gate.
- RGL - gate low resistor in series with the GL pin at the output of the GD3100 gate low driver and RoadPak module gate that controls the turn-off current for SiC MOSFET gate.
- RAMC - series resistor between RoadPak module gate and AMC input pin of the GD3100 driver for gate sensing and active Miller clamping.

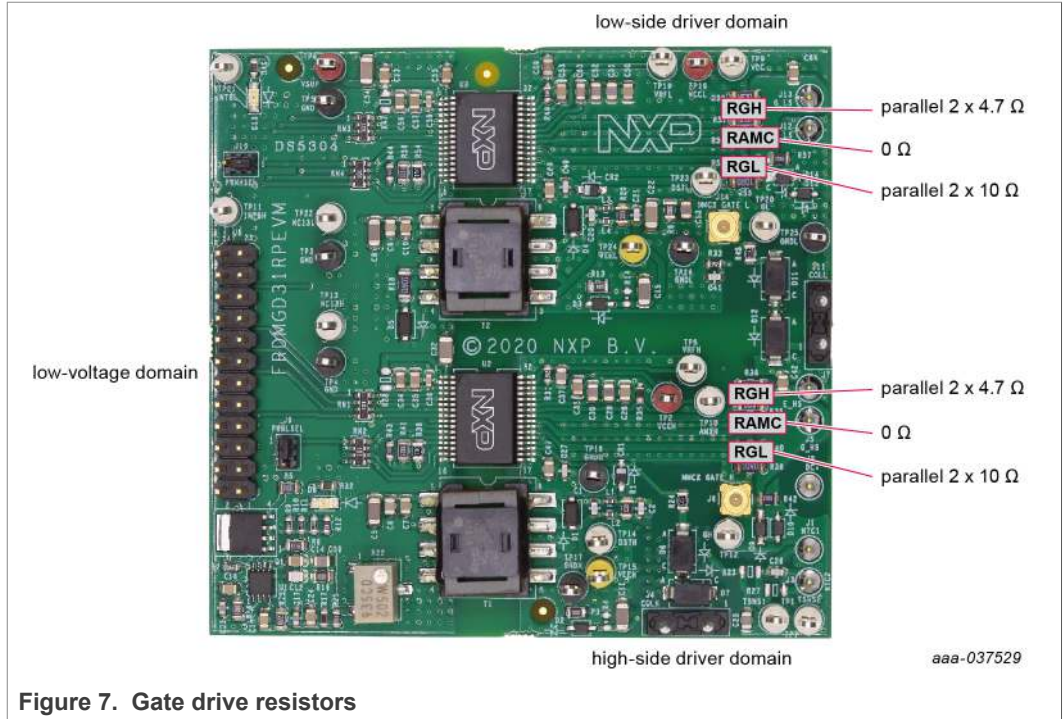

Figure 7. Gate drive resistors

4.4.6 LED interrupt indicators

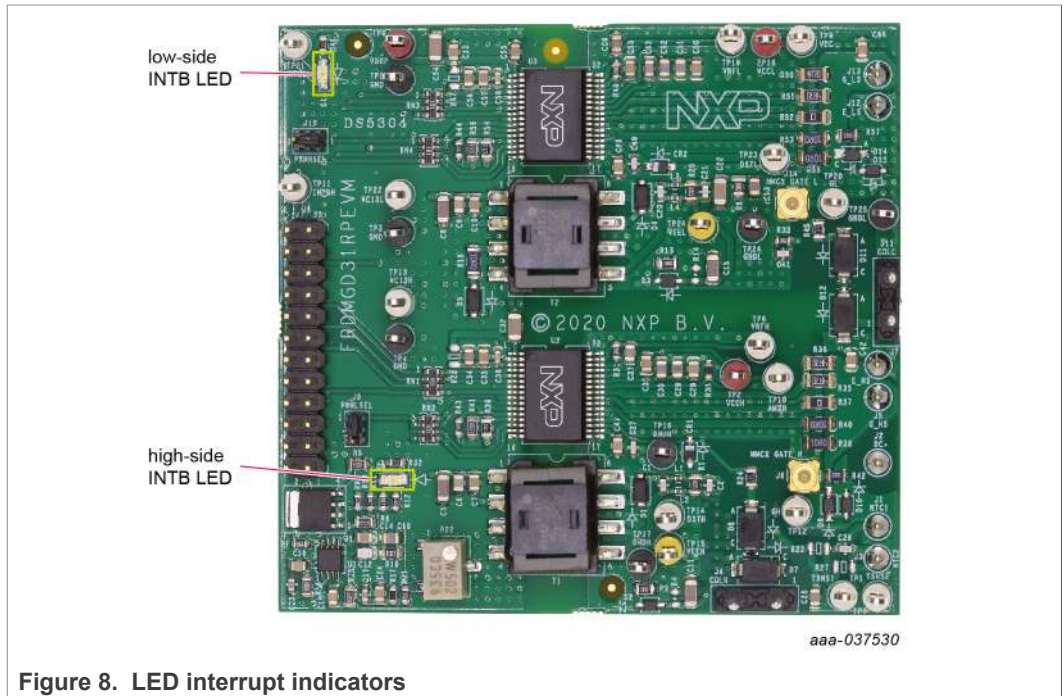

Figure 8. LED interrupt indicators

Table 5. LED interrupt indicators

LED	Description
Low-side INTB	connected to the INTB output pin of low-side driver indicating reported fault status when on (active LOW)
High-side INTB	connected to the INTB interrupt output pin of high-side driver indicating reported fault status when on (active LOW)

4.5 Kinetis KL25Z Freedom board

The Freedom KL25Z is an ultra low-cost development platform for Kinetis L series MCU built on Arm Cortex-M0+ processor.

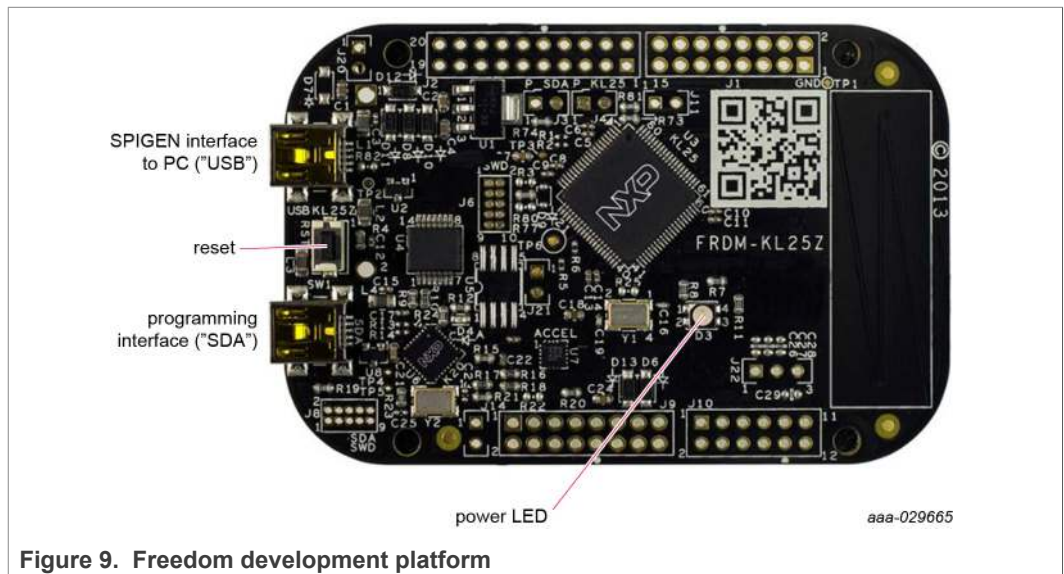

Figure 9. Freedom development platform

4.6 3.3 V to 5.0 V translator board

KITGD3160TREVB translator enables level shifting of signals from MCU 3.3 V to 5.0 V SPI communication.

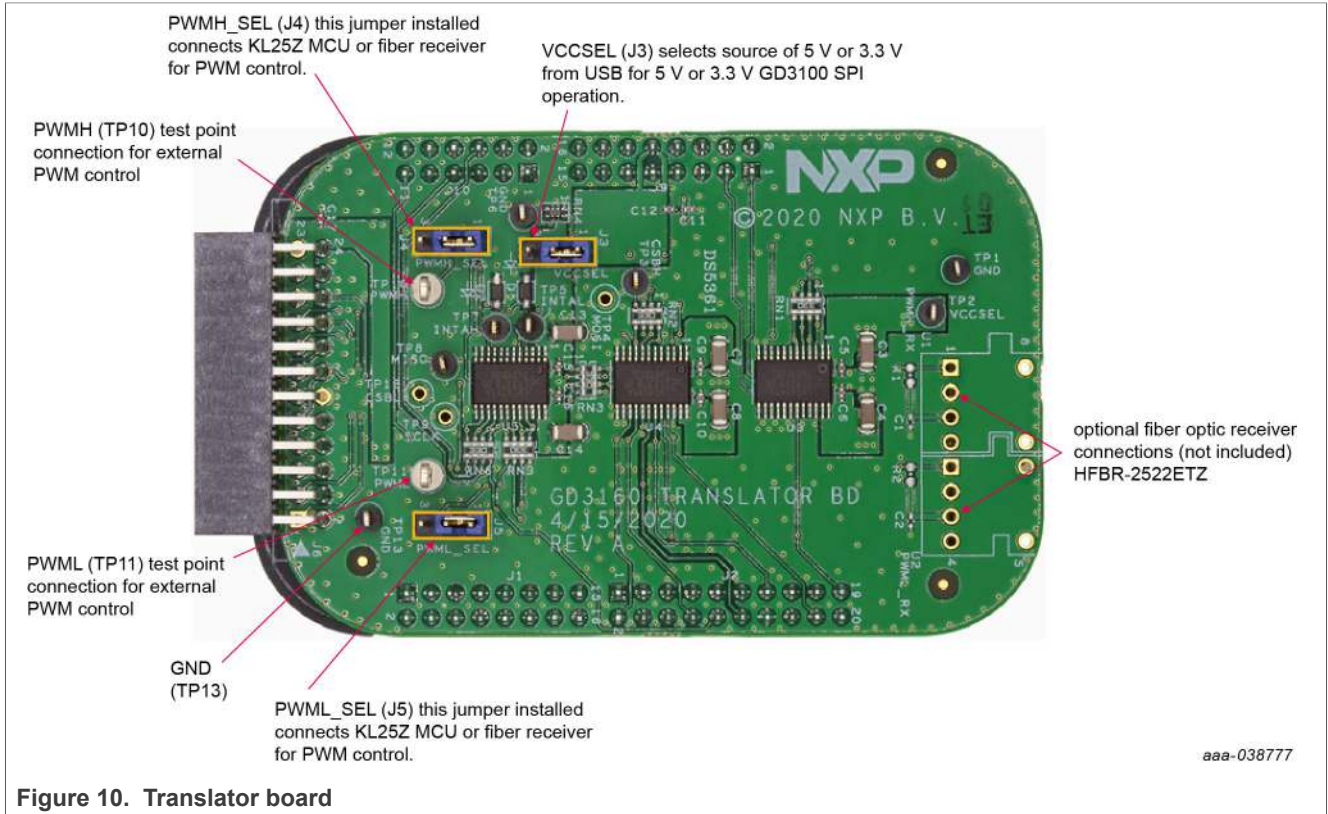

Figure 10. Translator board

Table 6. Translator board jumper definitions

Jumper	Position	Function
VCCSEL (J3)	1-2	selects 5.0 V for 5.0 V compatible gate drive
	2-3	selects 3.3 V for 3.3 V compatible gate drive
PWMH_SEL (J4)	1-2	selects PWM high-side control from KL25Z MCU
	2-3	selects PWM high-side control from fiber optic receiver inputs
PWML_SEL (J5)	1-2	selects PWM low-side control from KL25Z MCU
	2-3	selects PWM low-side control from fiber optic receiver inputs

5 Configuring the hardware

FRDMGD31RPEVM is connected to compatible SiC MOSFET RoadPak module with a DC link capacitor as shown in Figure 11. Double pulse and short-circuit testing can be conducted utilizing Windows based PC with FlexGUI software.

Suggested equipment needed for test:

- Rogowski coil high-current probe
- High-voltage differential voltage probe
- High sample rate digital oscilloscope with probes
- DC link capacitor (power ring 700D407 425 μ F, 900 V DC)
- SiC MOSFET RoadPak module
- Windows based PC
- High-voltage DC power supply for DC link voltage
- Low-voltage DC power supply for VSUP
 - +12 V DC gate drive board low-voltage domain
- Voltmeter for monitoring high-voltage DC link supply
- Load coil for double pulse and short-circuit testing

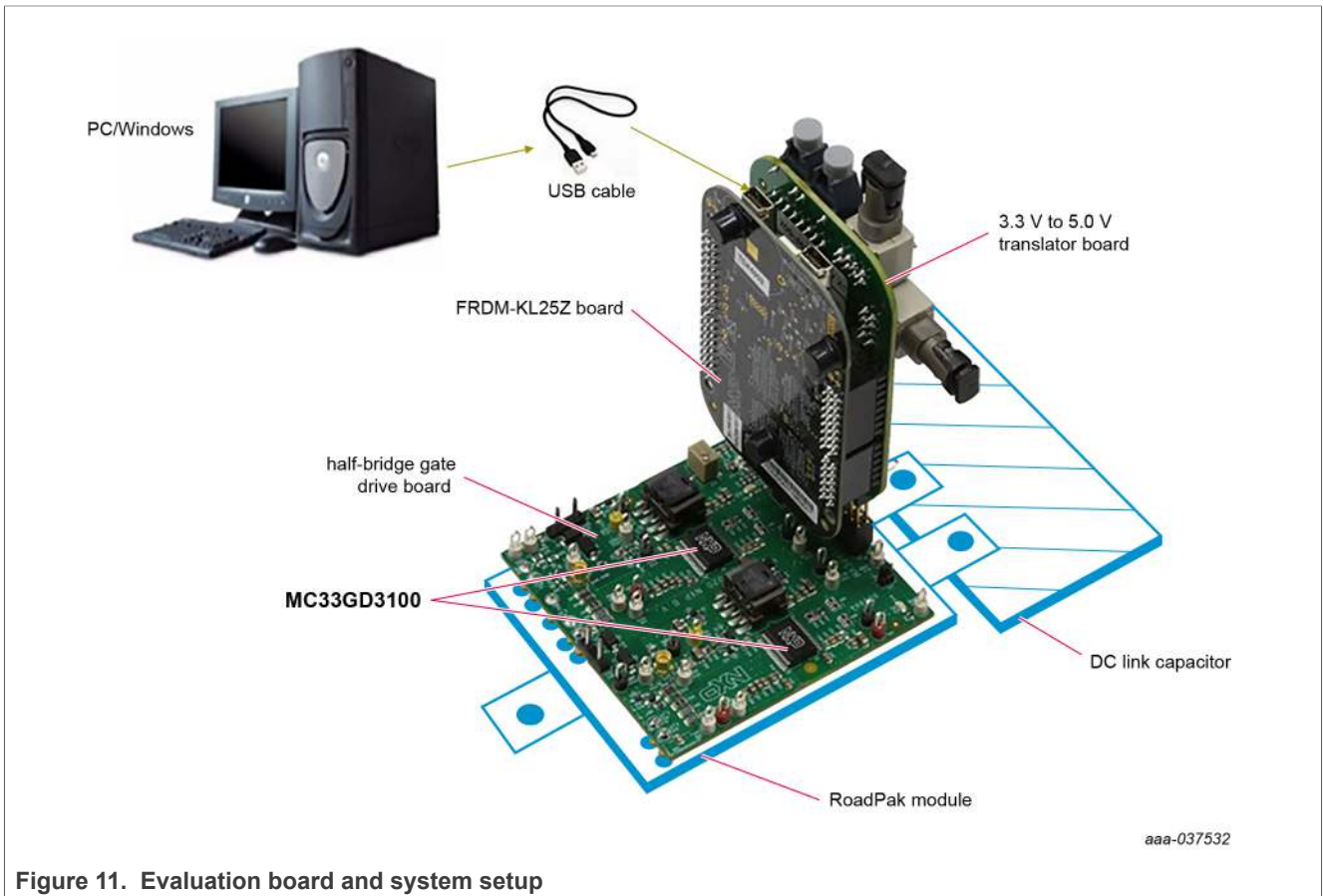

Figure 11. Evaluation board and system setup

6 Installation and use of software tools

Software for FRDMGD31RPEVM is distributed with the FlexGUI tool (available on NXP.com). Necessary firmware comes pre-installed on the FRDM-KL25Z with the kit.

Even if the user intends to test with other software or PWM, it is recommended to install this software as a backup or to help debugging.

6.1 Installing FlexGUI on your computer

The latest version of FlexGUI supports the GD3100 and GD3160. It is designed to run on any Windows 10 or Windows 8 based operating system. To install the software, do the following:

1. Go to www.nxp.com/FlexGUI and click **Download**.
2. When the FlexGUI software page appears, click **Download** and select the version associated with your PC operating system.
3. FlexGUI wizard creates a shortcut, an NXP FlexGUI icon appears on the desktop. By default, the FlexGUI executable file is installed at **C:\flexgui-app-des-gd31xx.exe**. Installing the device drivers overwrites any previous FlexGUI installation and replaces it with a current version containing the GD31xx drivers. However, configuration files (.spi) from the previous version remain intact.

6.2 Configuring the FRDM-KL25Z microcode

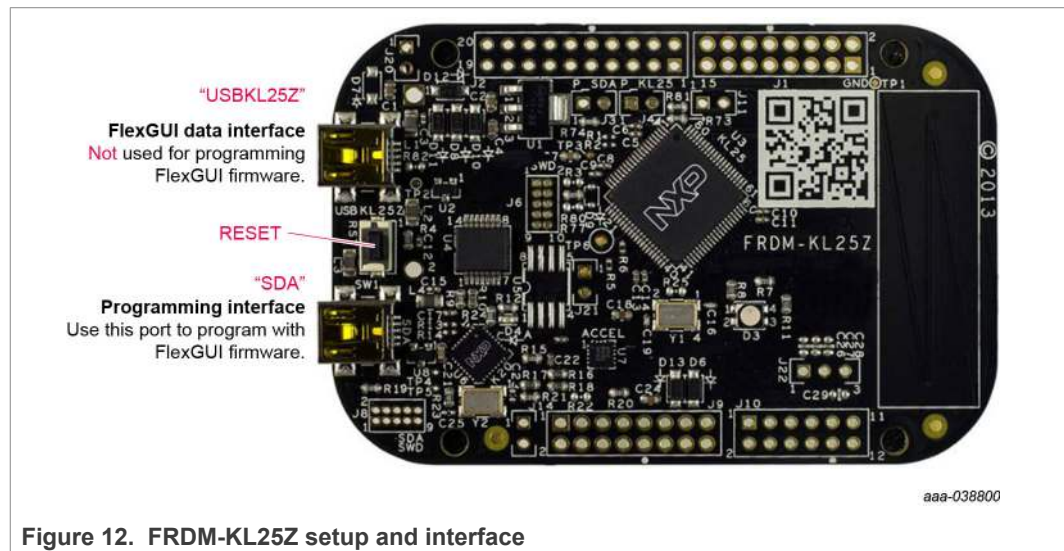

By default, the FRDM-KL25Z delivered with this kit is preprogrammed with the current and most up-to-date firmware available for the kit.

A way to check quickly that the microcode is programmed and the board is functioning properly, is to plug the KL25Z into the computer, open FlexGUI, and verify that the software version at the bottom is 6.4 or later (see [Figure 13](#)).

If a loss of functionality following a board reset, reprogramming, or a corrupted data issue, the microcode may be rewritten per the following steps:

1. To clear the memory and place the board in boot loader mode, hold down the reset button while plugging a USB cable into the **OpenSDA** USB port.
2. Verify that the board appears as a **BOOTLOADER** device and continue with step 3. If the board appears as **KL25Z**, you may go to step 6.
3. Download the **Firmware Apps** .zip archive from the PEmicro OpenSDA webpage (<http://www.pemicro.com/opensda/>). Validate your email address to access the files.
4. Find the most recent **MDS-DEBUG-FRDM-KL25Z_Pemicro_v118.SDA** and copy/drag-and-drop into the **BOOTLOADER** device.

5. Reboot the board by unplugging and replugging the connection to the **OpenSDA** port. Verify now that the device appears as a KL25Z device to continue.
6. Locate the most recent KL25Z firmware; which is distributed as part of the FlexGUI package.
 - a. From the FlexGUI install directory, which is located in the **flexgui-app-des-gd31xx\bin** folder and is named in the form “flexgui-fw-KL25Z_usb_hid_gd31xxC_vx.x.x.bin”.
 - b. This .bin file is a product/family-specific configuration file for FRDM-KL25Z containing the pin definitions, SPI/PWM generation code, and pin mapping assignments necessary to interface with the translator board as part of FRDMGD31RPEVM.
7. With the KL25Z still plugged through the **OpenSDA** port, copy/drag-and-drop the .bin file into the KL25Z device memory. Once done, disconnect the USB and plug into the other USB port, labeled **KL25Z**.
 - a. The device may not appear as a distinct device to the computer while connected through the KL25Z USB port, this is normal.
8. The FRDM-KL25Z board is now fully set up to work with FRDMGD31RPEVM and the FlexGUI.
 - a. There is no software stored or present on either the driver or translator boards, only on the FRDM-KL25Z MCU board.

All uploaded firmware is stored in non-volatile memory until the reset button is hit on the FRDM-KL25Z. There is no need to repeat this process upon every power up, and there is no loss of data associated with a single unplug event.

6.3 Using the FlexGUI

The FlexGUI is available from <http://www.nxp.com/FlexGUI> as an evaluation tool demonstrating GD31xx-specific functionality, configuration, and fault reporting. FlexGUI also includes basic capacity for the FRDMGD31RPEVM to control an IGBT or SiC module, enabling double pulse or short-circuit testing.

SPI messages can be realized graphically or in hexadecimal format. CSB is selectable to address one or both GD31xx on the board via daisy chain. See [Figure 13](#) to [Figure 32](#) for FlexGUI for GD31xx internal register read and write access.

Starting FlexGUI for GD31xx

- FlexGUI install program (flexgui-app-des-gd31xx-0.x.x.exe)
- Download FlexGUI and run the install program on your PC.
- When you start the application, [Figure 13](#) allows you to select the target application board, feature set (standard or daisy chain), target MCU, and USB interface. Leave all settings as shown.

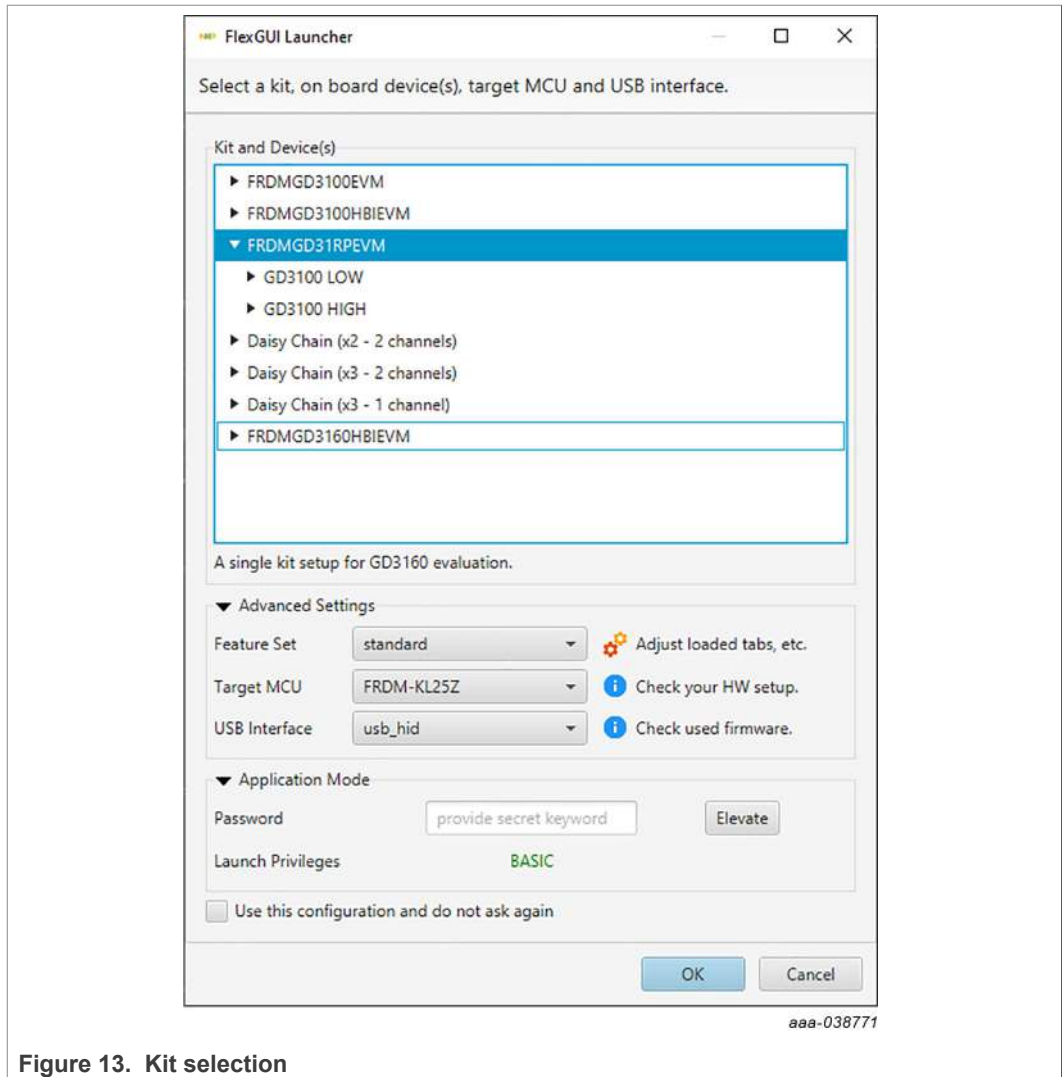

Figure 13. Kit selection

FlexGUI settings

- Access settings by selecting Settings from the File menu

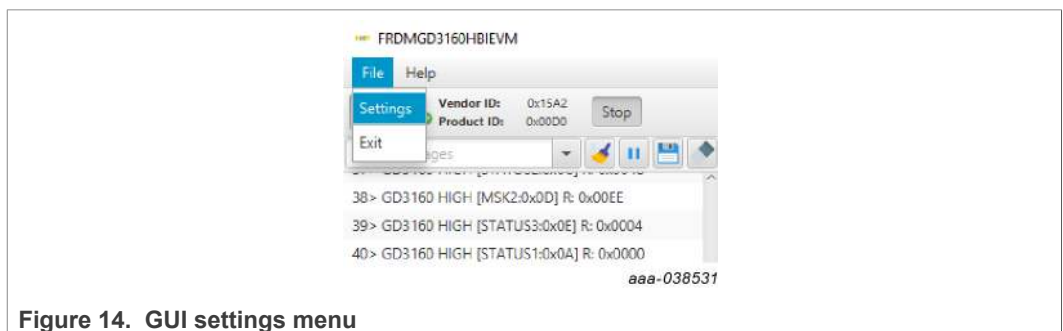

Figure 14. GUI settings menu

- The Loader and Logs settings are shown below:

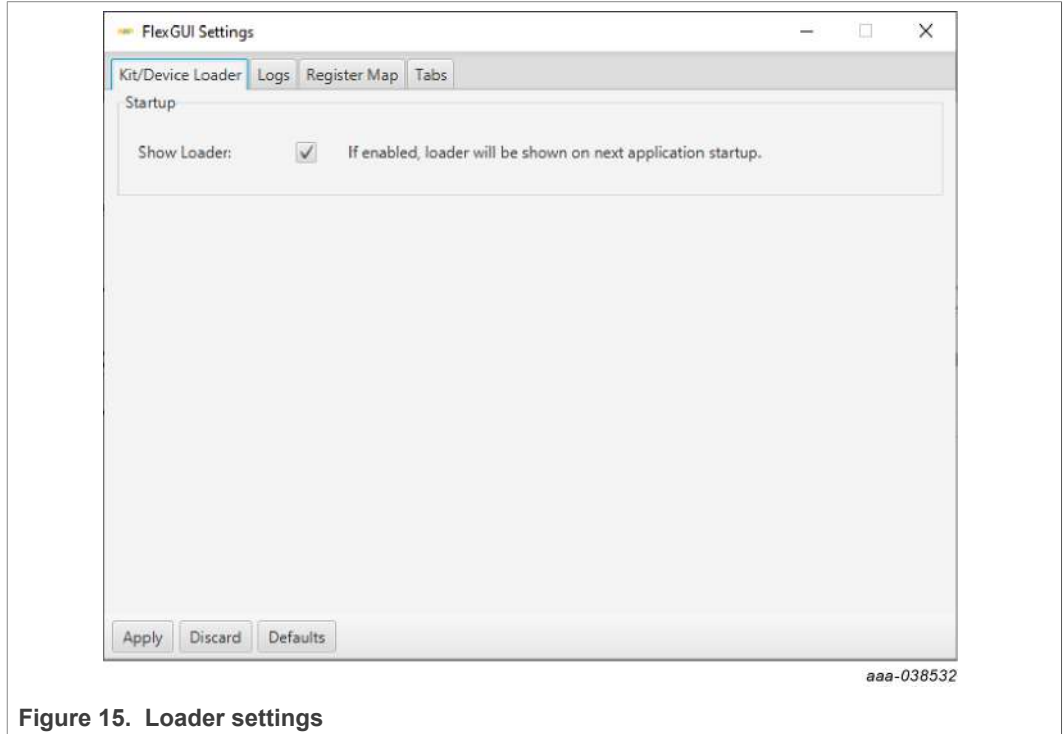

Figure 15. Loader settings

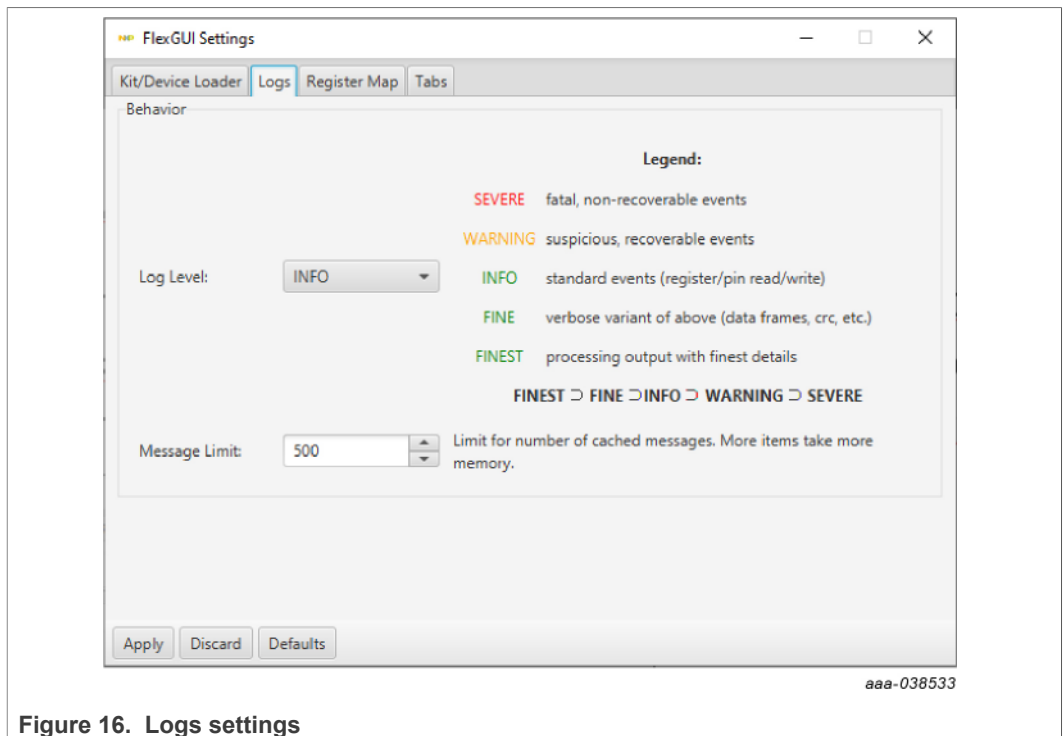
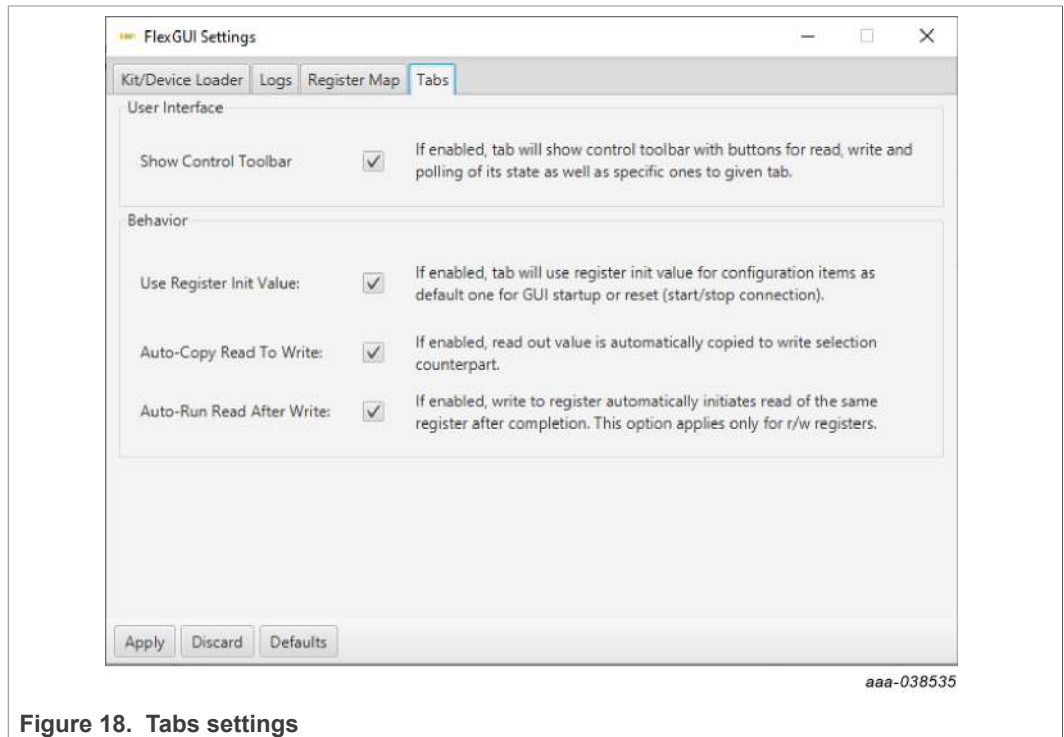
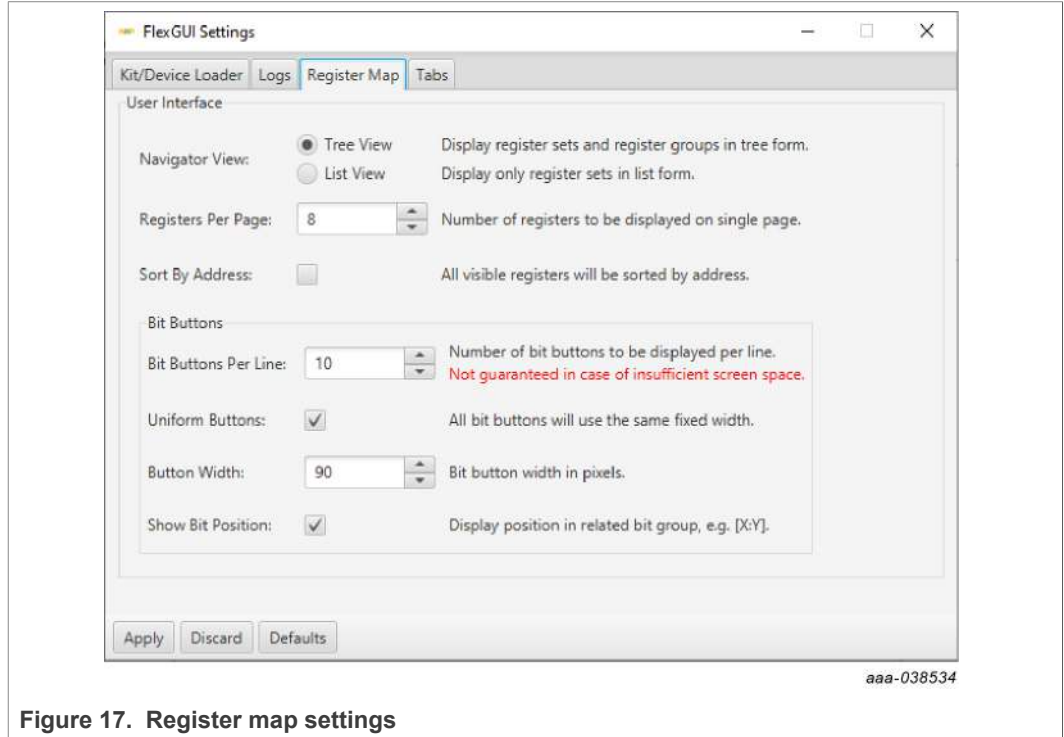

Figure 16. Logs settings

- Access settings by selecting Settings from the File menu.
- The Register Map and Tabs settings are shown below:



Command Log window

- The Command Log area informs the user about application events.

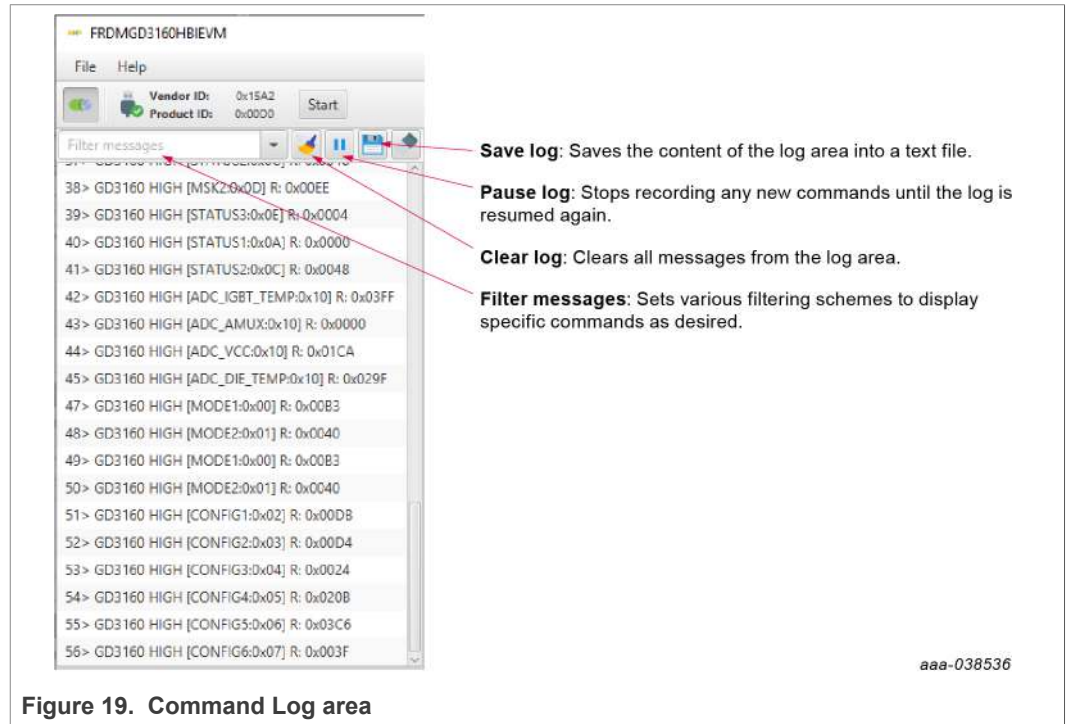

Figure 19. Command Log area

Global workspace controls

- Always visible in the lower left corner of the main application window.
 - GD3160 tab functionality
 - Switch modes between run and configuration mode
 - Set SPI frequency



Figure 20. Device pins settings and status menus

- Pins tab functionality
 - Set control levels. Default values are shown.
 - Read and automatically poll INTB pins (INTA pins are added for GD3160).
 - Control pins set values to a default to a functional state.
 - FSENB - enable/disable fail-safe enable
 - EN_PS - enables flyback supply on EVB at 17 V V_{CC} on high side and low side
 - FSSTATEL and FSSTATEH set the fail-safe state when FSENB is enabled
 - PWML and PWMH set the default state PWM inputs for high side and low side

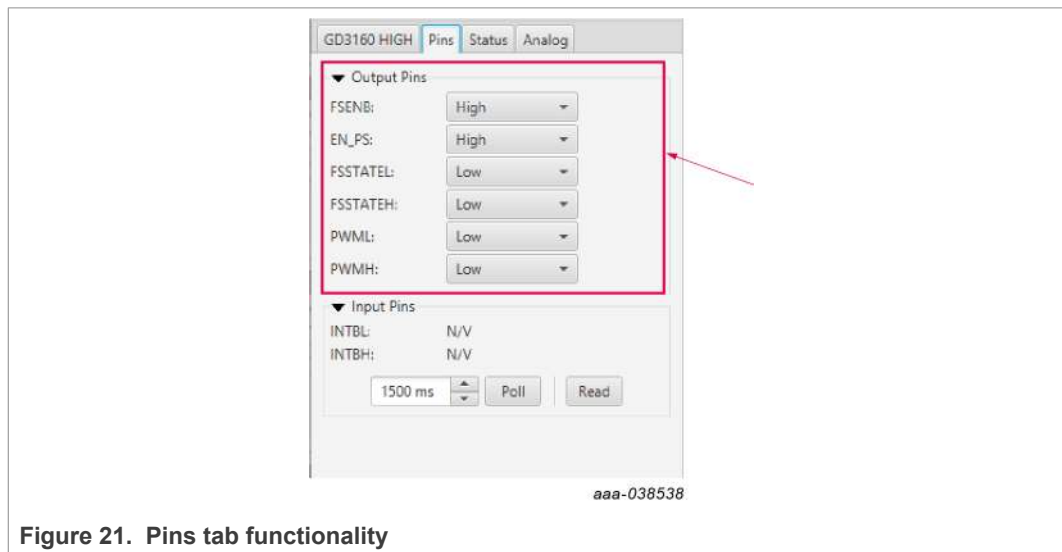

Figure 21. Pins tab functionality

- Status tab functionality
 - Monitors Status 1 and Status 2 fault bits. Bits that are set are shown in red.
 - Ability to clear all faults and automatically poll status registers.

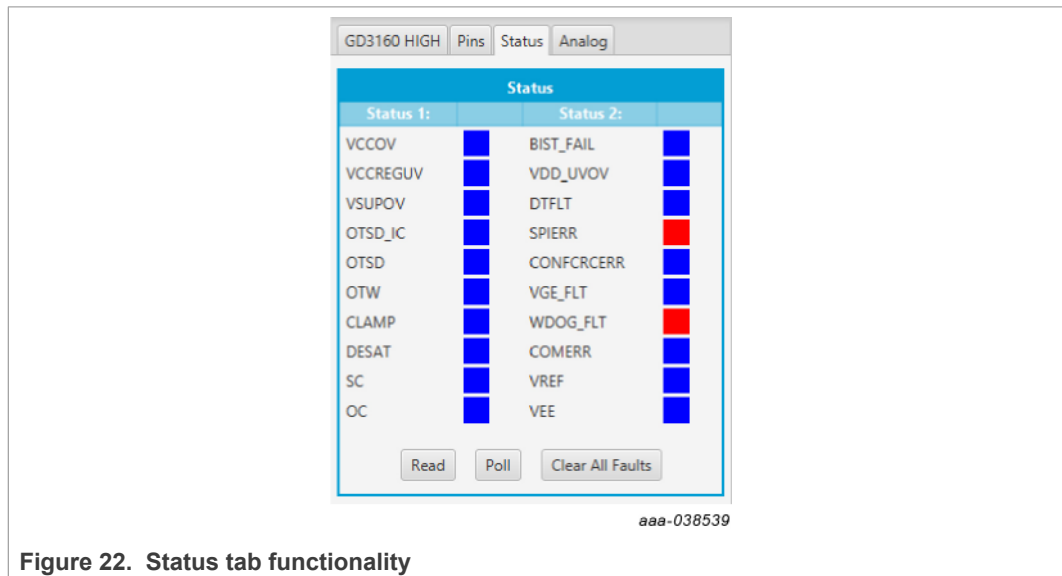

Figure 22. Status tab functionality

- Analog tab functionality
 - Read and poll ADC values from the high-voltage domain
 - Displays raw ADC and converted values



Figure 23. Analog tab functionality

Register map

- Registers are grouped according to function; independent lines to read and write the registers
- Individual registers can be read by clicking the R button and can be written by using the W button.
- Copy button to copy the read values to the write line; can be set to copy automatically
- Reset button to undo the changes on the write line and reset to the previous value
- Global register controls perform the selected command on all registers with the checkbox selected.

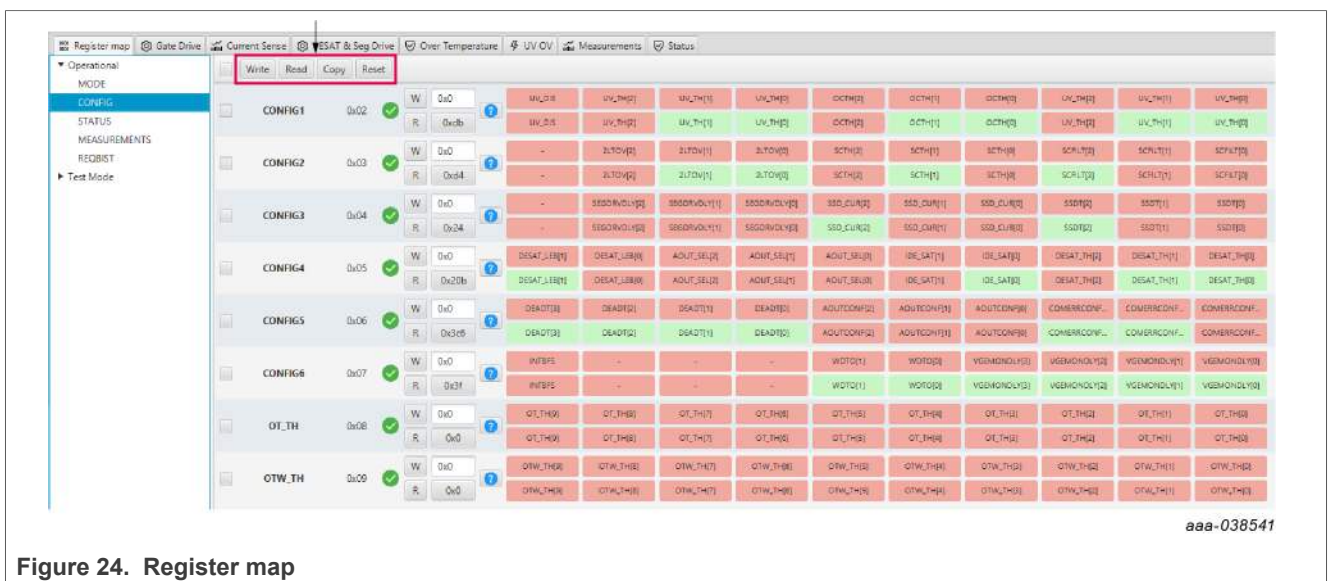

Figure 24. Register map

Gate Drive tab

- Allows setting of parameters related to the gate drive; controls are disabled when not in config mode
- Provides a more intuitive visual way to set parameters
- All settings are automatically synchronized with the register controls.

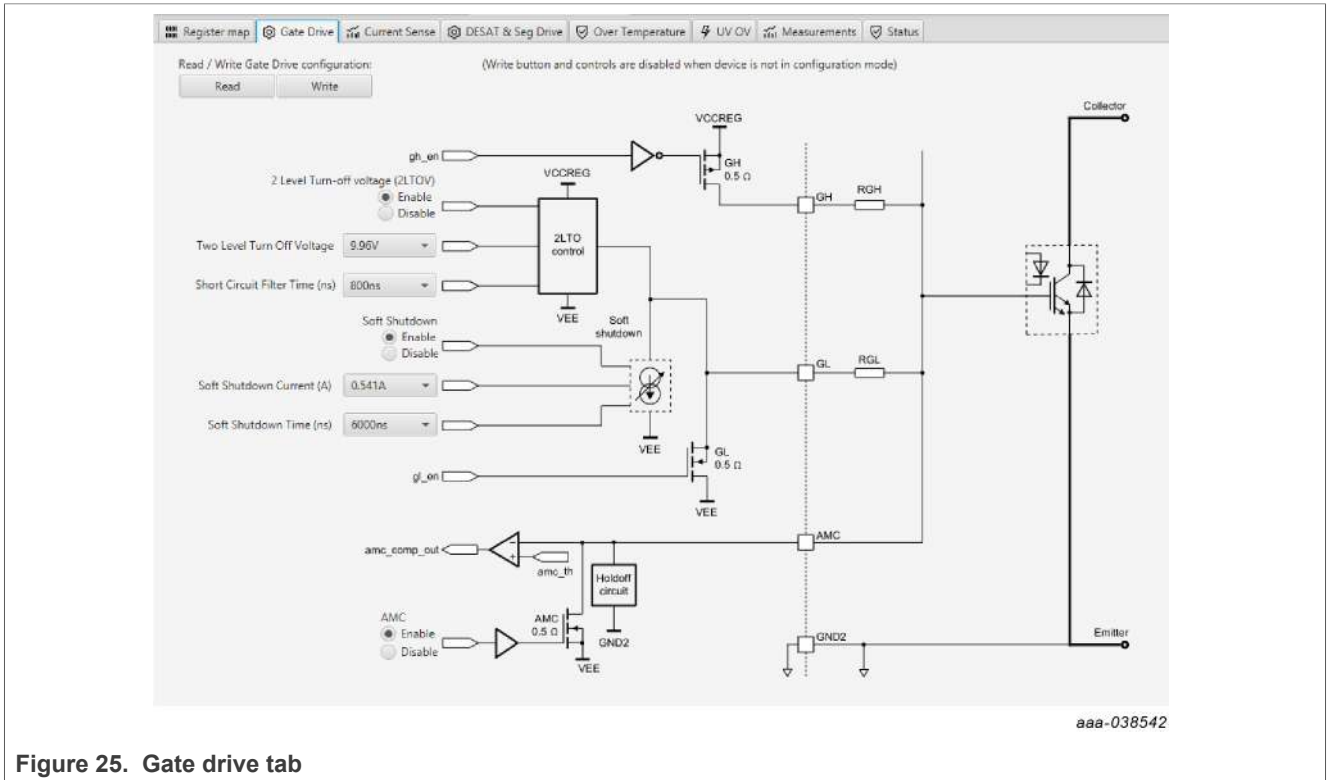

Figure 25. Gate drive tab

Current Sense tab

- Allows setting of parameters related to current sense
- Provides a more intuitive visual way to set parameters
- All settings are automatically synchronized with the register controls.

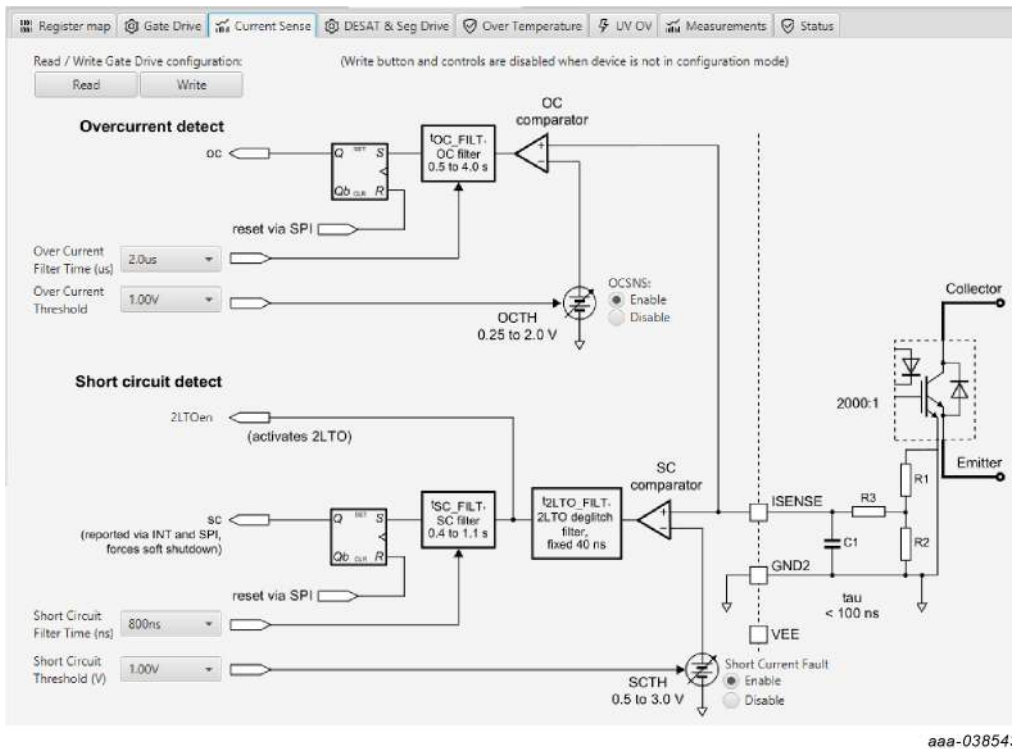

Figure 26. Current sense tab

DESAT & Seg Drive tab

- Allows setting of parameters related to desat and segmented drive
- Provides a more intuitive visual way to set parameters
- All settings are automatically synchronized with the register controls.

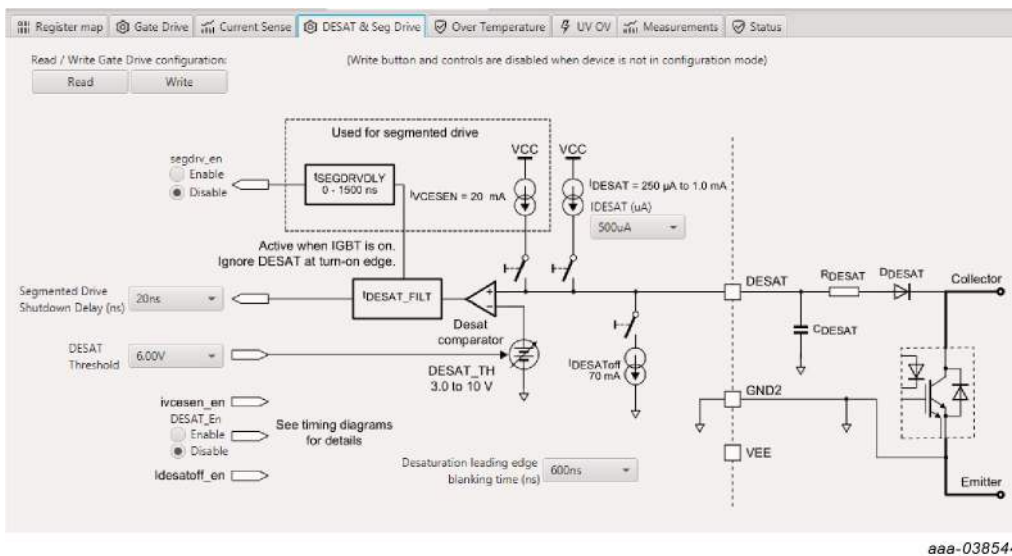
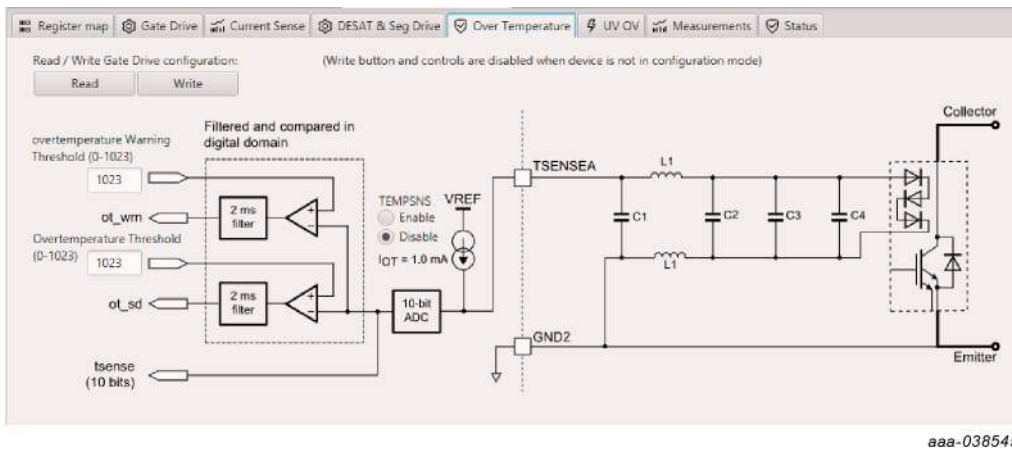

Figure 27. Desat and segmented drive tab

Overtemperature tab

- Allows setting of parameters related to overtemperature and overtemperature warning thresholds
- Provides a more intuitive visual way to set parameters
- All settings are automatically synchronized with the register controls.



aaa-038545

Figure 28. Overtemperature tab

Undervoltage threshold tab

- Allows setting of parameters related to undervoltage threshold
- Provides a more intuitive visual way to set parameters
- All settings are automatically synchronized with the register controls.

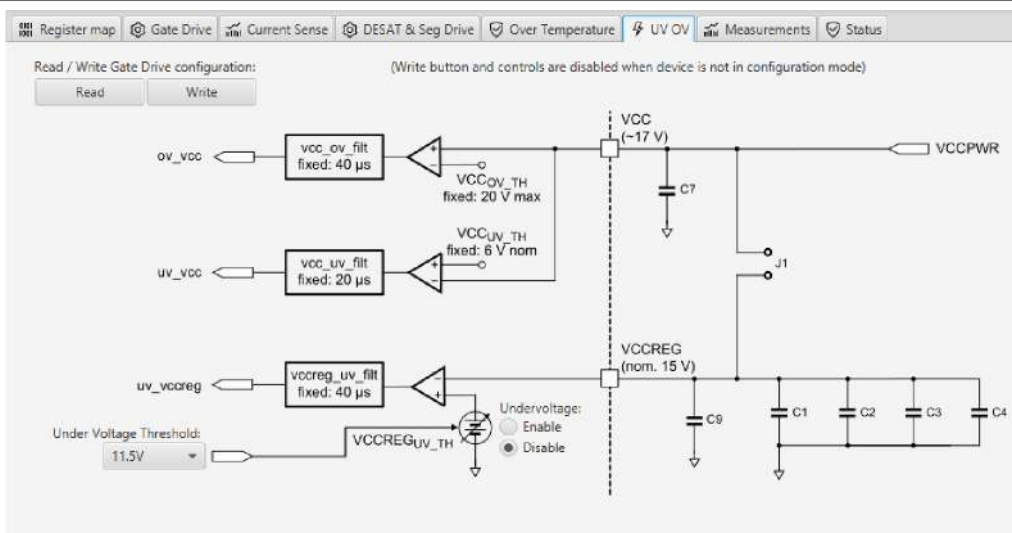

aaa-038546

Figure 29. Undervoltage and overvoltage tab

Measurements tab

- Allows monitoring and graphing of ADC and temperature values

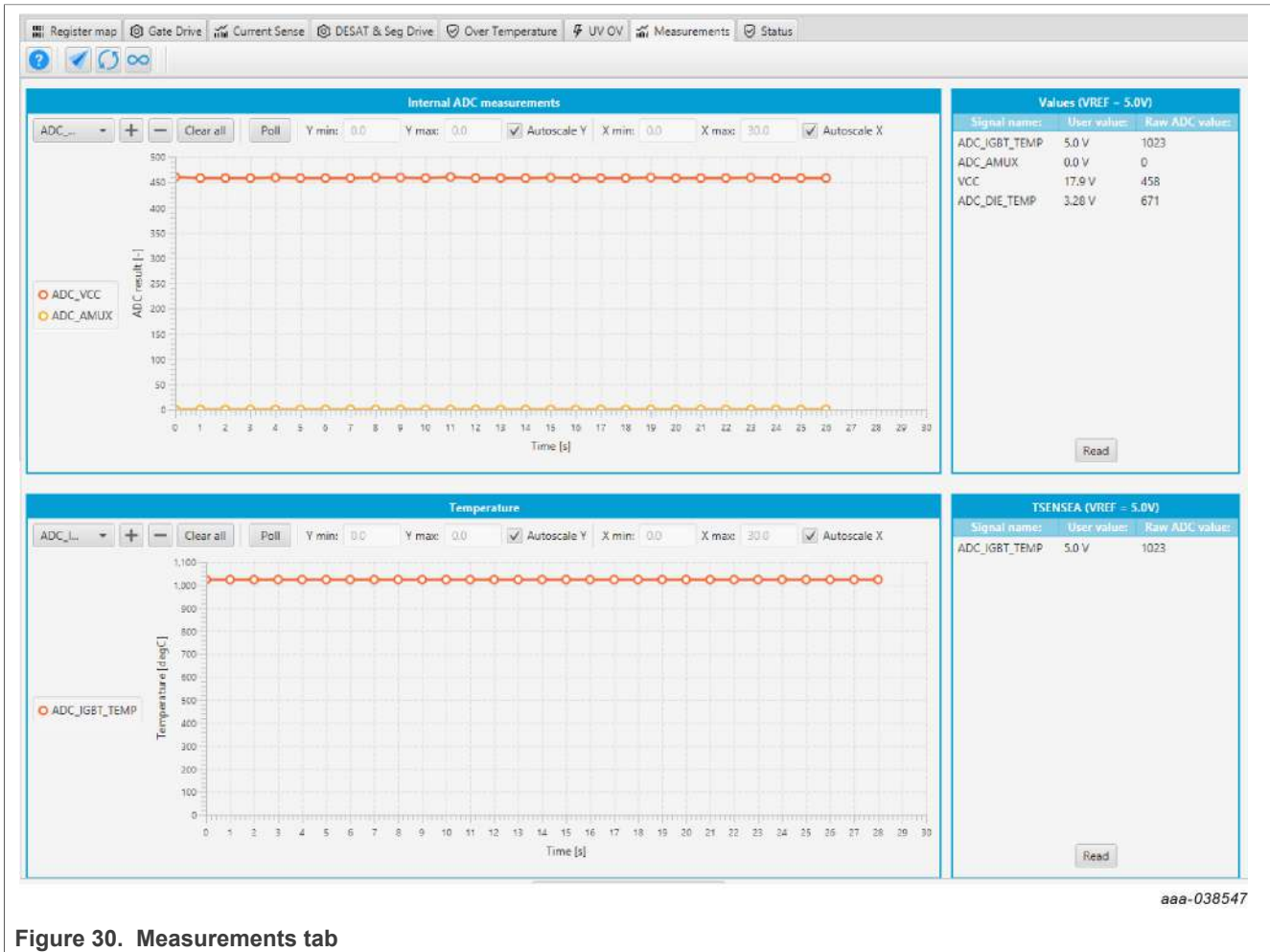

Figure 30. Measurements tab

Status tab

- Allows monitoring of Status 1, Status 2, and Status 3 register values
- Status 1 and Status 2 faults can be cleared
- Status mask registers can be modified when in configuration mode

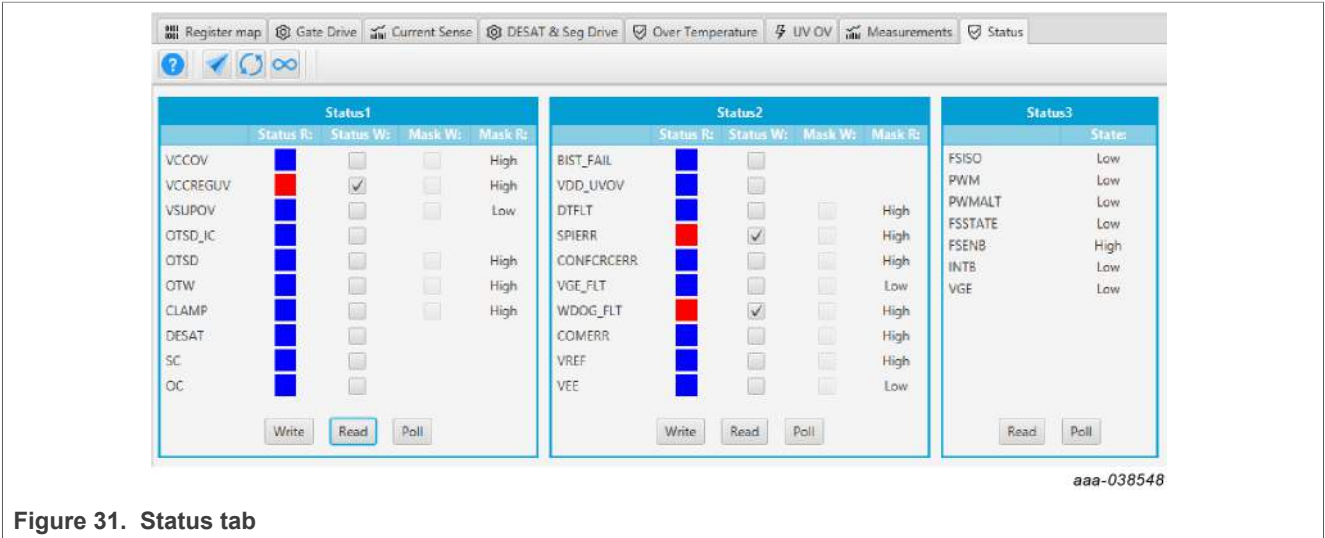

Figure 31. Status tab

Pulse tab

- Used for double pulse, short circuit, and PWM testing
- Select desired T1, T2, and T3 timings for each test type; select enable then generate pulses

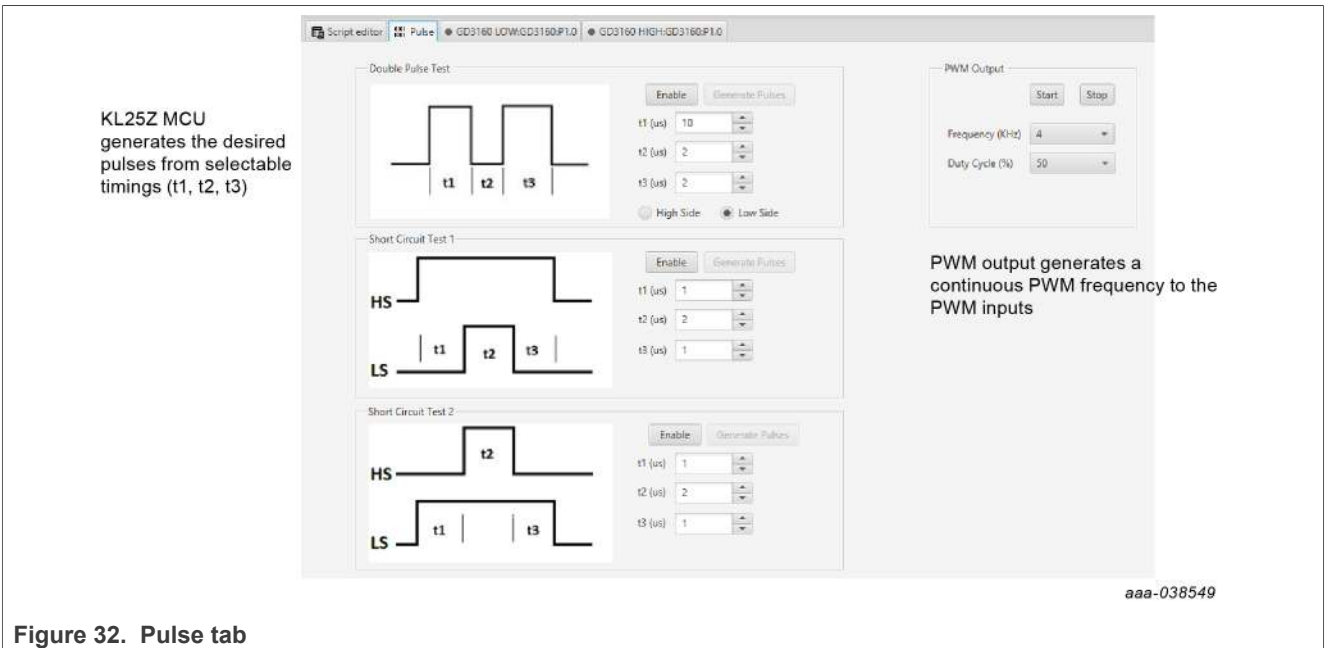

Figure 32. Pulse tab

6.4 Troubleshooting

Some common issues and troubleshooting procedures are detailed below. This is not an exhaustive list by any means, and additional debug may be needed:

FRDMGD31RPEVM half-bridge evaluation board

Problem	Evaluation	Explanation	Corrective action(s)
No PWM output (no fault reported)	Check PWM jumper position on translator board	Incorrect PWM jumpers obstruct signal path but not report fault	Set PWMH_SEL (J4) and PWML_SEL (J5) jumpers properly, for desired control method: <ul style="list-style-type: none"> 3.3 V to 5.0 V translator board reviewed in Section 4.6
	Check PWM control signal	Ensure that proper PWM signal is reaching GD3100	Monitor EXT_PWML (TP14) and EXT_PWMH (TP15) for commanded PWM state
	Check FSENB status (see GD3100 pin 15, STATUS3)	PWM is disabled when FSENB = LOW	Set pin FSENB = HIGH (pin 15) to continue
	Check CONFIG_EN bit (MODE2)	PWM is disabled when CONFIG_EN is logic 1	Write CONFIG_EN = logic 0 to continue
No PWM output (fault reported)	Check VGE fault (VGE_FLT)	A short on IGBT or SiC module gate, or too low of VGEMON delay setting causes VGE fault, locking out PWM control of the gate.	Clear VGE_FLT bit (STATUS2) to continue. Increase VGEMON delay setting (CONFIG6). If safe operating condition can be guaranteed, set VGE_FLTM (MSK2) bit to logic 0, to mask fault.
	Check for short-circuit fault (SC) in STATUS1 register	SC is a severe fault that disables PWM. SC fault cannot be masked	Clear SC fault to continue. Consider adjusting SC fault settings on GD3100: <ul style="list-style-type: none"> Adjust short-circuit threshold setting (CONFIG2) Adjust short-circuit filter setting (CONFIG2)
PWM output is good, but with persistent fault reported	Check for dead time fault (DTFLT) in STATUS2 register	Dead time is enforced, but fault indicates that PWM controls signals are in violation	Clear DTFLT fault bit (STATUS2). Check PWMHSEL (J10) and PWMLSEL (J9) are configured to bypass dead time faults. Consider adjusting dead time settings on GD3100: <ul style="list-style-type: none"> Change mandatory PWM dead time setting (CONFIG5) Mask dead time fault (MSK2)
	Check for overcurrent (OC) fault in STATUS1 register	OC fault latches, but does not disable PWM. OC fault cannot be masked.	Clear OC fault bit (STATUS1). Adjust OC fault detection settings on GD3100: <ul style="list-style-type: none"> Adjust overcurrent threshold setting (CONFIG1) Adjust overcurrent filter setting (CONFIG1)
PWM or FSSTATE rising edge has longer delay than falling edge	Check translator output voltage versus GD3100 VDD voltage	Low translator output voltage (compared with correct VDD at GD3100) causes the high threshold at the GD3100 pin to be crossed later than commanded	Check translator output voltage selection (J233) is configured to the same level as the GD3100 VDD Check VCCSEL supply or translator outputs on the translator board for excessive loading or supply droop/pulldown
WDOG_FLT reported on startup	Check VSUP and VCC are powered	On initialization, watchdog fault is reported when one die is powered up before the other	Check VSUP and VCC both have power applied. Clear WDOG_FLT bit (STATUS2) to continue.
SPIERR reported on startup	Check KL25Z/translator connection	On initialization, SPIERR can occur when the SPI bus is open, or when GD3100 IC is powered up before the translator (which provides CSB).	Clear SPIERR fault to continue. Reinitialize power to GD3100 after translator is powered (over USB).

Problem	Evaluation	Explanation	Corrective action(s)
SPIERR reported after SPI message	Check bit length of message sent	There is SPIERR if SCLK does not see a $n \times 24$ multiple of cycles	Use 24-bit message length for SPI messages
	Check CRC	SPIERR faults if CRC provided in sent message is not good	Use FlexGUI to generate commands with valid CRC. The command can be copied in binary or hexadecimal and sent from another program.
	Check for sufficient dead time between SPI messages	SPIERR fault bit is set when the time between SPI messages (txfer_delay) received is too short. Minimum required delay time is 19 μ s.	Check time between CSB rising edge (old message end) and CSB falling edge (new message start) during normal SPI read, and ensure transfer delay dead time check. SPIERR can also be cleared in BIST.
VCCREGUV reported on startup	Check VCCREG potential	Caused by low VCC	Clear VCCREGUV fault bit (STATUS1). Tune VCC-GNDISO potential with power supply set resistor (R20).
VREFUV reported on startup	Check HV domain is powered correctly	Related to slow rise time of VCC supply on HV domain, or failed VREF regulator	Clear VREFUV bit (STATUS2). Reset HV domain supply if fault bit does not clear.
	Check VCC for undervoltage condition	Low VCC is visible indirectly through other HV domain faults	Tune VCC-GNDISO using R20 feedback
VCCOV fault reported on startup	Check VEE level on suspect domain.	If VEE level is not at desired negative voltage it could cause excessive VCC level.	Check Zener diode in power supply circuit for proper value in setting VEE level. Clear VCCOV bit (STATUS1) to continue.
	Check VCC-GNDISO potential	PWM is disabled during a VCC overvoltage (20 V nom.)	Tune VCC-GNDISO potential to suitable level with power supply set resistor (R22). Clear VCCOV bit (STATUS1) to continue.
No PWM during short circuit test	Check PWMxSEL jumpers	Incorrect configuration of PWMALT pins prevent short-circuit test by enforcing dead time	For short-circuit test, set PWMLSEL (J9) and PWMHSEL (J10) to bypass dead time. See Section 4.4.3 for details.
Bad SPI data, appears to repeat previous response	Check VSUP/VDD for undervoltage condition	VDD_UV latches SPI buffer contents, preventing updated fault reporting.	Check voltage provided at VDD pin (pin 3). On each read, compare the address from the sent command and response (a difference indicates that the SPI response is latched due to inactive). Read multiple addresses to ensure a good comparison.
	Check PS_EN is set to HIGH in FlexGUI; see Figure 21	VCC/VEE can be enabled/disabled in software.	Enable VCC/VEE from FlexGUI
	Check VCC for undervoltage	Unpowered VCC prevents HV domain from updating data	Tune VCC-GNDISO using R22 feedback

7 Schematics, board layout, and bill of materials

The board schematics, board layout, and bill of materials are available at <http://www.nxp.com/FRDM-GD3100EVM> on the Overview tab under Get Started.

8 References

- [1] Tool summary page for FRDM-GD3100EVM <http://www.nxp.com/FRDM-GD3100EVM>
- [2] Product summary page for GD3100 device <http://www.nxp.com/GD3100>

9 Revision history

Revision history

Revision	Date	Description
v.2	20210122	Section 6.2 list item 6a : changed FlexGUI version
v.1	20200803	initial version

10 Legal information

10.1 Definitions

Draft — A draft status on a document indicates that the content is still under internal review and subject to formal approval, which may result in modifications or additions. NXP Semiconductors does not give any representations or warranties as to the accuracy or completeness of information included in a draft version of a document and shall have no liability for the consequences of use of such information.

10.2 Disclaimers

Limited warranty and liability — Information in this document is believed to be accurate and reliable. However, NXP Semiconductors does not give any representations or warranties, expressed or implied, as to the accuracy or completeness of such information and shall have no liability for the consequences of use of such information. NXP Semiconductors takes no responsibility for the content in this document if provided by an information source outside of NXP Semiconductors. In no event shall NXP Semiconductors be liable for any indirect, incidental, punitive, special or consequential damages (including - without limitation - lost profits, lost savings, business interruption, costs related to the removal or replacement of any products or rework charges) whether or not such damages are based on tort (including negligence), warranty, breach of contract or any other legal theory. Notwithstanding any damages that customer might incur for any reason whatsoever, NXP Semiconductors' aggregate and cumulative liability towards customer for the products described herein shall be limited in accordance with the Terms and conditions of commercial sale of NXP Semiconductors.

Right to make changes — NXP Semiconductors reserves the right to make changes to information published in this document, including without limitation specifications and product descriptions, at any time and without notice. This document supersedes and replaces all information supplied prior to the publication hereof.

Applications — Applications that are described herein for any of these products are for illustrative purposes only. NXP Semiconductors makes no representation or warranty that such applications will be suitable for the specified use without further testing or modification. Customers are responsible for the design and operation of their applications and products using NXP Semiconductors products, and NXP Semiconductors accepts no liability for any assistance with applications or customer product design. It is customer's sole responsibility to determine whether the NXP Semiconductors product is suitable and fit for the customer's applications and products planned, as well as for the planned application and use of customer's third party customer(s). Customers should provide appropriate design and operating safeguards to minimize the risks associated with their applications and products. NXP Semiconductors does not accept any liability related to any default, damage, costs or problem which is based on any weakness or default in the customer's applications or products, or the application or use by customer's third party customer(s). Customer is responsible for doing all necessary testing for the customer's applications and products using NXP Semiconductors products in order to avoid a default of the applications and the products or of the application or use by customer's third party customer(s). NXP does not accept any liability in this respect.

Suitability for use in automotive applications — This NXP Semiconductors product has been qualified for use in automotive applications. Unless otherwise agreed in writing, the product is not designed, authorized or warranted to be suitable for use in life support, life-critical or safety-critical systems or equipment, nor in applications where failure or malfunction of an NXP Semiconductors product can reasonably be expected

to result in personal injury, death or severe property or environmental damage. NXP Semiconductors and its suppliers accept no liability for inclusion and/or use of NXP Semiconductors products in such equipment or applications and therefore such inclusion and/or use is at the customer's own risk.

Export control — This document as well as the item(s) described herein may be subject to export control regulations. Export might require a prior authorization from competent authorities.

Evaluation products — This product is provided on an "as is" and "with all faults" basis for evaluation purposes only. NXP Semiconductors, its affiliates and their suppliers expressly disclaim all warranties, whether express, implied or statutory, including but not limited to the implied warranties of non-infringement, merchantability and fitness for a particular purpose. The entire risk as to the quality, or arising out of the use or performance, of this product remains with customer. In no event shall NXP Semiconductors, its affiliates or their suppliers be liable to customer for any special, indirect, consequential, punitive or incidental damages (including without limitation damages for loss of business, business interruption, loss of use, loss of data or information, and the like) arising out of the use of or inability to use the product, whether or not based on tort (including negligence), strict liability, breach of contract, breach of warranty or any other theory, even if advised of the possibility of such damages. Notwithstanding any damages that customer might incur for any reason whatsoever (including without limitation, all damages referenced above and all direct or general damages), the entire liability of NXP Semiconductors, its affiliates and their suppliers and customer's exclusive remedy for all of the foregoing shall be limited to actual damages incurred by customer based on reasonable reliance up to the greater of the amount actually paid by customer for the product or five dollars (US\$5.00). The foregoing limitations, exclusions and disclaimers shall apply to the maximum extent permitted by applicable law, even if any remedy fails of its essential purpose.

Translations — A non-English (translated) version of a document is for reference only. The English version shall prevail in case of any discrepancy between the translated and English versions.

Security — Customer understands that all NXP products may be subject to unidentified or documented vulnerabilities. Customer is responsible for the design and operation of its applications and products throughout their lifecycles to reduce the effect of these vulnerabilities on customer's applications and products. Customer's responsibility also extends to other open and/or proprietary technologies supported by NXP products for use in customer's applications. NXP accepts no liability for any vulnerability. Customer should regularly check security updates from NXP and follow up appropriately. Customer shall select products with security features that best meet rules, regulations, and standards of the intended application and make the ultimate design decisions regarding its products and is solely responsible for compliance with all legal, regulatory, and security related requirements concerning its products, regardless of any information or support that may be provided by NXP. NXP has a Product Security Incident Response Team (PSIRT) (reachable at PSIRT@nxp.com) that manages the investigation, reporting, and solution release to security vulnerabilities of NXP products.

10.3 Trademarks

Notice: All referenced brands, product names, service names and trademarks are the property of their respective owners.

Kinetis — is a trademark of NXP B.V.

NXP — wordmark and logo are trademarks of NXP B.V.

SafeAssure — is a trademark of NXP B.V.

Tables

Tab. 1.	Device features	5	Tab. 4.	Jumper definitions	10
Tab. 2.	Low-voltage domain 24-pin connector definitions	7	Tab. 5.	LED interrupt indicators	13
Tab. 3.	Test point definitions	9	Tab. 6.	Translator board jumper definitions	14

Figures

Fig. 1.	FRDMGD31RPEVM	1	Fig. 16.	Logs settings	19
Fig. 2.	Connecting FRDM-KL25Z, GD31xx half-bridge EVB and translator board	6	Fig. 17.	Register map settings	20
Fig. 3.	Evaluation board voltage and interface domains	7	Fig. 18.	Tabs settings	20
Fig. 4.	Key test point locations	8	Fig. 19.	Command Log area	21
Fig. 5.	Power supply and jumper configuration	10	Fig. 20.	Device pins settings and status menus	21
Fig. 6.	Evaluation board bottom view	11	Fig. 21.	Pins tab functionality	22
Fig. 7.	Gate drive resistors	12	Fig. 22.	Status tab functionality	22
Fig. 8.	LED interrupt indicators	12	Fig. 23.	Analog tab functionality	23
Fig. 9.	Freedom development platform	13	Fig. 24.	Register map	23
Fig. 10.	Translator board	14	Fig. 25.	Gate drive tab	24
Fig. 11.	Evaluation board and system setup	15	Fig. 26.	Current sense tab	25
Fig. 12.	FRDM-KL25Z setup and interface	16	Fig. 27.	Desat and segmented drive tab	25
Fig. 13.	Kit selection	18	Fig. 28.	Overtemperature tab	26
Fig. 14.	GUI settings menu	18	Fig. 29.	Undervoltage and overvoltage tab	26
Fig. 15.	Loader settings	19	Fig. 30.	Measurements tab	27
			Fig. 31.	Status tab	28
			Fig. 32.	Pulse tab	28

Contents

1	FRDMGD31RPEVM	1
2	Important notice	2
3	Getting started	3
3.1	Kit contents/packing list	3
3.2	Required equipment	4
3.3	System requirements	4
4	Getting to know the hardware	4
4.1	Overview	4
4.2	Board features	4
4.3	Device features	5
4.4	Board description	5
4.4.1	Low-voltage logic and control connector	6
4.4.2	Test point definitions	8
4.4.3	Power supply and jumper configuration	10
4.4.4	Bottom view	11
4.4.5	Gate drive resistors	11
4.4.6	LED interrupt indicators	12
4.5	Kinetis KL25Z Freedom board	13
4.6	3.3 V to 5.0 V translator board	14
5	Configuring the hardware	14
6	Installation and use of software tools	15
6.1	Installing FlexGUI on your computer	16
6.2	Configuring the FRDM-KL25Z microcode	16
6.3	Using the FlexGUI	17
6.4	Troubleshooting	28
7	Schematics, board layout, and bill of materials	30
8	References	30
9	Revision history	31
10	Legal information	32

Please be aware that important notices concerning this document and the product(s) described herein, have been included in section 'Legal information'.

© NXP B.V. 2021.

All rights reserved.

For more information, please visit: <http://www.nxp.com>

For sales office addresses, please send an email to: salesaddresses@nxp.com

Date of release: 22 January 2021

Document identifier: UM11401