

Quad, High Voltage Amplifier Array Demo Board

General Description

The Supertex HV264TS-G is a quad high voltage amplifier array device in a 24-pin TSSOP package. The HV264DB1 demo board provides a platform to evaluate this device. This demoboard requires only a minimum setup including a V_{DD} low voltage supply, a V_{PP} high voltage supply, and a signal source. The demoboard provides the input/output connections through two 6-pin headers.

For detailed electrical performance, please refer to the HV264 datasheet.

Specifications

Parameter	Value
V_{PP} high voltage supply	200V
V_{DD} low voltage supply	4.5 to 5.5V
HV_{OUT} output voltage swing	1.0V to $V_{PP} - 10V$
V_{IN} Input signal range	0 to $V_{DD} - 1.5V$
A_V closed loop gain	66.7V/V with internal feedback resistors
Typical SR output slew rate	9.0V/ μ s
I_{PEAK} output peak current	3.0mA

Board Layout

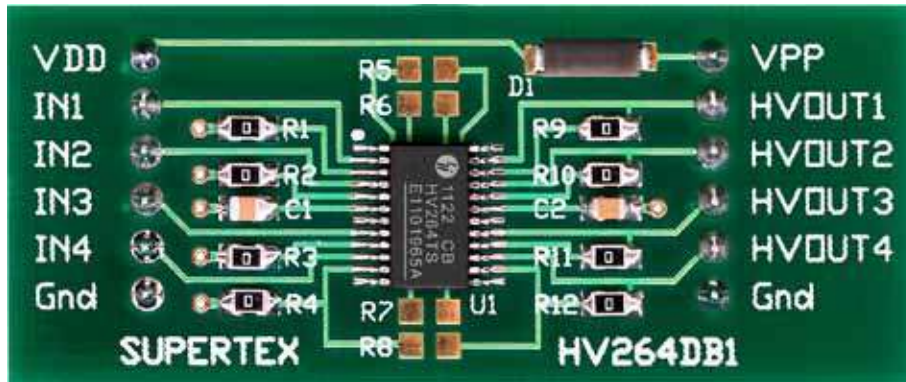

Pin Name	Description
VPP	High voltage positive supply
VDD	Low voltage positive supply
IN1 to IN4	Amplifier inputs
HVOUT1 to HVOUT4	Amplifier outputs
GND	Device ground

Acceptable Power Up Sequences

- 1) V_{DD} 2) V_{PP} 3) Inputs
- 1) V_{DD} 2) Inputs 3) V_{PP}

Acceptable Power Down Sequences

- 1) Inputs, 2) V_{PP}) V_{DD}
- 1) V_{PP}) Inputs) V_{DD}

Power Up/Down Sequence

The device can be damaged due to an improper power up / down sequence. To prevent damage, please follow the acceptable power up / down sequences. An external diode across V_{PP} and V_{DD} is included on the board, where the anode of the diode is connected to V_{DD} and the cathode is connected to V_{PP} . Any low current high voltage diode will be adequate.

Gain Setting

The HV264 quad amplifier array has the internal built-in gain setting resistors available with a fixed gain of 66.7V/V +/- 5%. External gain setting resistors can be used for applications that require better tolerance or a different closed loop gain. An example is shown in the following schematics. Fig. 1 shows the schematics of the demoboard. The external resistor values and tolerances can be selected to meet different gain setting and precision requirements as shown in Fig. 2.

Schematics

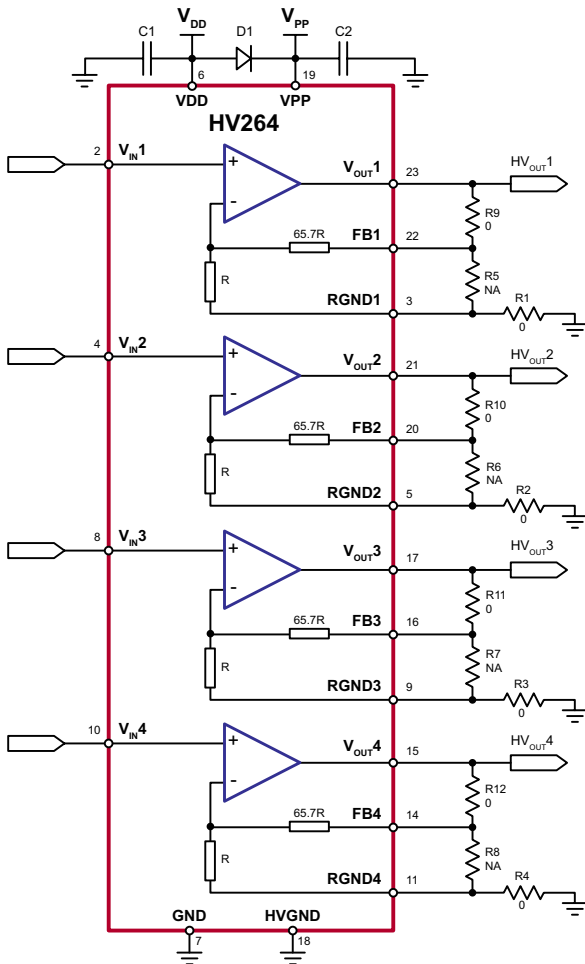

Fig. 1. Demo Board Resistor Settings

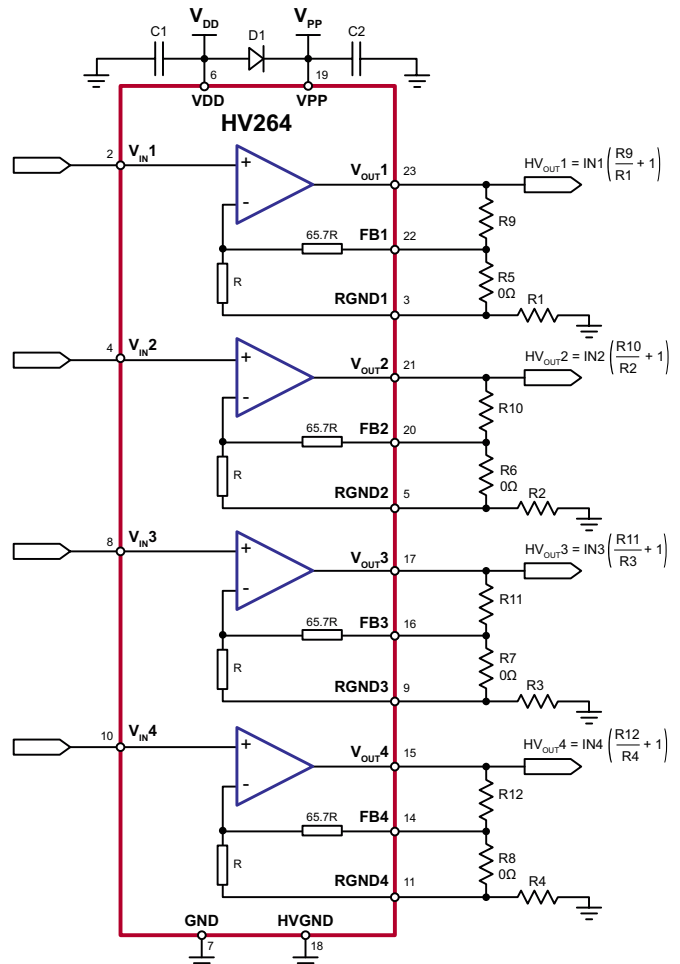

Fig. 2. High Precision Gain Settings Using External Resistors

Bill of Materials

Item	RefDes	Description	Package	Manufacturer	Part #
1	C1	0.1µF +/-10%, 25V X7R chip capacitor	0805	Any	---
2	C2	1.0nF +/-10%, 250V X7R chip capacitor	0805	Any	---
3	D1	400V, 1.0A, general purpose diode	SMA	Any	USIG
4	R1 ,R2, R3, R4, R9, R10, R11, R12	0Ω chip resistors	0805	Any	---
5	R5, R6, R7, R8	chip resistors (not installed)	0805	Any	---
6	U1	225V, 3.0mA amplifier array	24-pin TSSOP	Supertex	HV264TS-G

Supertex inc. does not recommend the use of its products in life support applications, and will not knowingly sell them for use in such applications unless it receives an adequate "product liability indemnification insurance agreement." **Supertex inc.** does not assume responsibility for use of devices described, and limits its liability to the replacement of the devices determined defective due to workmanship. No responsibility is assumed for possible omissions and inaccuracies. Circuitry and specifications are subject to change without notice. For the latest product specifications refer to the **Supertex inc.** (website: <http://www.supertex.com>)