

NOTES:

1. MATERIALS AND FINISHES:  
 BODY - ZINC DIE CAST, NICKEL PLATING  
 CONTACT - PHOSPHOR BRONZE, GOLD PLATING (.000003 THICK)  
 @ CONTACT AREA ONLY, TIN PLATING AT TAIL, NICKEL PLATED OVERALL  
 INSULATOR - POLYPROPYLENE  
 HOUSING - PBT 15% G.F., BLACK  
 ROUND PIN - BRASS, TIN PLATING  
 GROUNDING TERMINAL - STEEL, TIN PLATING
2. ELECTRICAL:  
 A. IMPEDANCE: 75 OHM  
 B. FREQUENCY RANGE: DC - 1 GHz  
 C. DIELECTRIC WITHSTANDING VOLTAGE: 1500 VRMS, MIN.
3. MECHANICAL:  
 A. DURABILITY: 500 CYCLES MIN.  
 B. TEMPERATURE RANGE: -55° C TO 85° C
4. PACKAGING:  
 A. PACKAGED IN PACKING TRAYS  
 B. QUANTITY PER TRAY: 40
5. SEPERATELY SUPPLIED MOUNTNG HARDWARE TO BE TIGHTENED TO 10 IN-LBS MIN/15 IN-LBS MAX WHEN ASSEMBLING TO PANEL

THIRD ANGLE PROJ.

REVISIONS

REV	DESCRIPTION	DATE	ECO	APPR
A	RELEASE TO MFG	9/23/89	42639	CPM
B	PIN CHANGED	4/8/05	45496	CPM
C	UPDATED FORMAT AND NOMINAL ENVELOPE DIMENSIONS	9/10/12	49195	EW

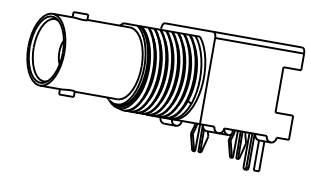

SCALE 1.000

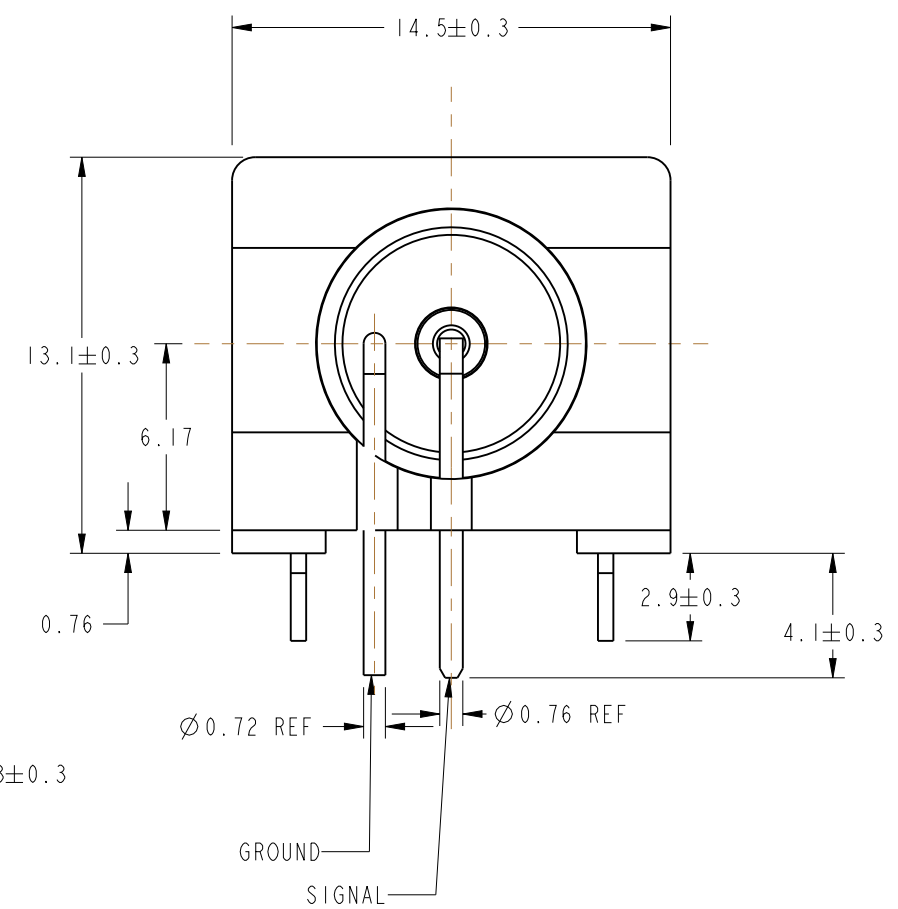
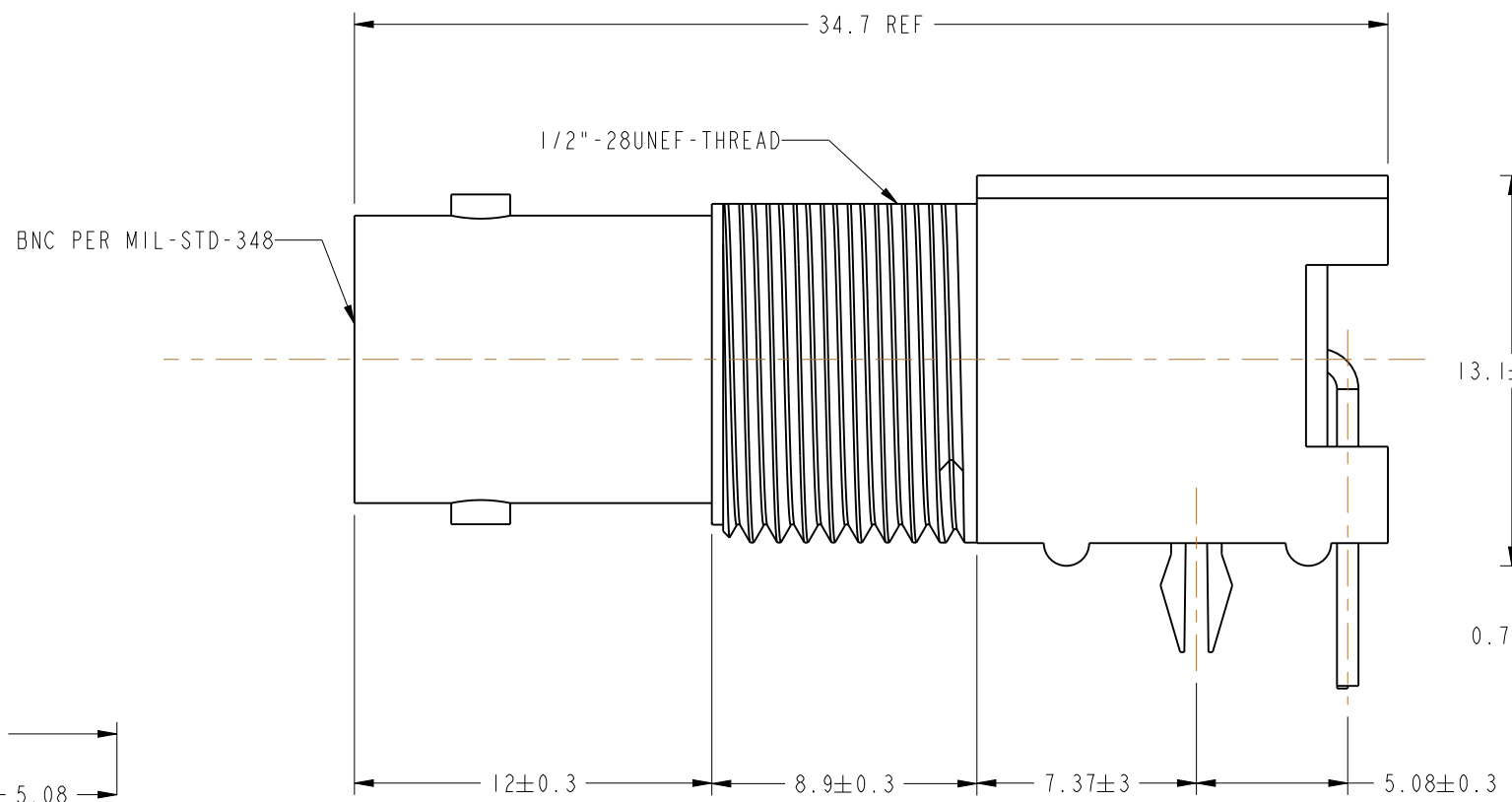
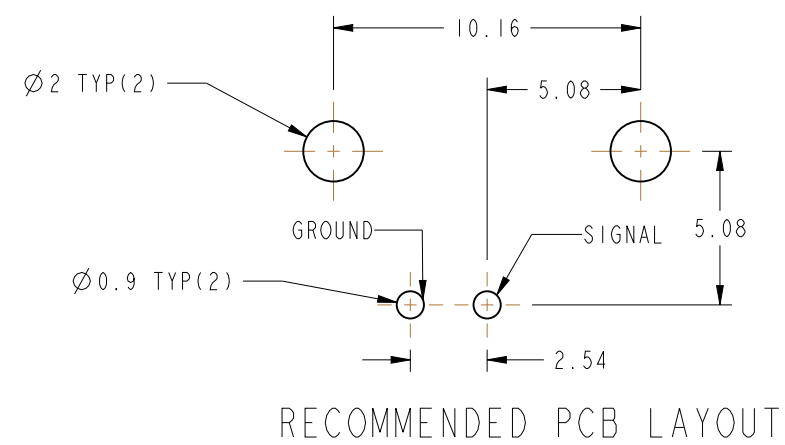
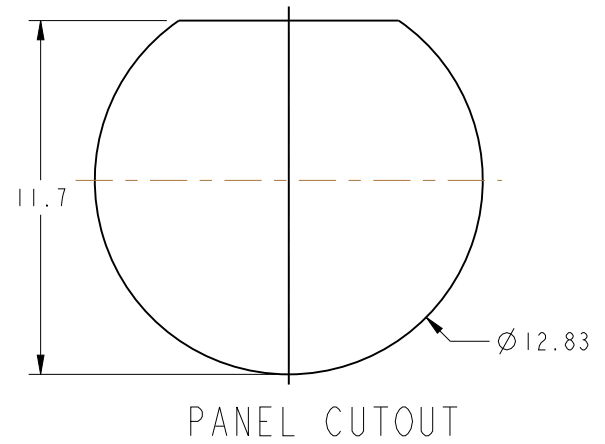

**CUSTOMER OUTLINE DRAWING**  
 ALL OTHER SHEETS ARE FOR INTERNAL USE ONLY

UNLESS OTHERWISE SPECIFIED, DIMENSIONS ARE IN METRIC AND TOLERANCES ARE: <0.5mm ±0.05mm    0.5 - 6mm ±0.1mm    6 - 30mm ±0.2mm    30 - 120mm ±0.3mm    ANGLES ±1°	MATERIAL	DRAWN	DATE	TITLE 75 OHM BNC R/A JACK, ISOLATED LOW PROFILE	Amphenol RF www.amphenolrf.com
		ERIC WANKOFF	26-Jun-12		
	REFERENCE	ENGINEER	DATE	SCALE: 4.0:1.0    SHEET 2 OF 2	DRAWING NO. 31-71053-1010 ITEM NO. 31-71053-1010 PART NO. 31-71053-1010
	CONFIGURATION LEVEL:	T AUBIN	8/31/98		
FINISH	APPROVED	DATE	DWG SIZE	REV	
	T AUBIN	9/21/98	B	C	
NOTICE - These drawings, specifications, or other data (1) are, and remain the property of Amphenol corp. (2) must be returned upon request; and (3) are confidential and not to be disclosed to any person other than those to whom they are given by Amphenol Corp. the finishing of these drawings, specifications, or other data by Amphenol Corp., or to any other person to anyone for any purpose is not to be regarded by implication or otherwise in any manner licensing, granting rights to permitting such holder or any other sperson to manufacture, use or sell any product, process or design, patented or otherwise, that may in any way be related to or disclosed by said drawings, specifications, or other data.	CAD FILE				